



The 4th International Workshop on Healthcare Open Data, Intelligence and Interoperability
(HODII)
November 7-9, 2023, Almaty, Kazakhstan

Architecture proposal for deploying and integrating intelligent models in ABI

Rui Gomes^a, Júlio Duarte^a, Cesar Quintas^b, Maria Manuel Salazar^a,
Manuel Filipe Santos^{a,*}

^aALGORITMI/LASI Research Center, University of Minho, Guimarães, Portugal

^bCentro Hospitalar Universitário de Santo António, Porto, Portugal

Abstract

The integration of Adaptive Business Intelligence systems in healthcare has garnered significant attention due to their potential to manage the ever-growing volume of healthcare data and enhance the quality of care provided to society. ABI systems also play a crucial role in supporting hospital administrators in making strategic decisions. To facilitate the transparency and interoperability of these solutions, the scientific community has embarked on various studies to develop technologic architectures capable of meeting the complex requirements of healthcare settings.

One of the key challenges in adopting this technology is the creation and integration of prediction and optimization models in an automated and semi-autonomous manner. This article presents a novel and robust microservices architecture designed to streamline the deployment of intelligent models and seamlessly integrate them within the ABI system.

This paper begins by introducing the problem of deploying and integrating intelligent models into ABI systems, providing essential context on ABI systems within the healthcare domain. Subsequently, it details the proposed architecture, outlining its technical approaches and highlighting the advantages it brings to the healthcare ecosystem. Finally, the paper concludes by summarizing the contributions and future directions for research in this critical area, emphasizing the potential impact of this architecture on improving healthcare intelligence systems.

© 2024 The Authors. Published by Elsevier B.V.

This is an open access article under the CC BY-NC-ND license (<https://creativecommons.org/licenses/by-nc-nd/4.0>)

Peer-review under responsibility of the Conference Program Chairs

Keywords: Adaptive Business Intelligence, ABI systems

* Corresponding author.

E-mail address: mfs@dsi.uminho.pt

1. Introduction

The integration of Adaptive Business Intelligence (ABI) systems in Healthcare is a topic that has been widely discussed, not only because of their ability to support the data that is generated on a daily basis but also because of the expectation of inserting the evolution of an intelligent system into the improvement of the care provided to society, while supporting hospital administrators in managing the strategic decisions inherent in the running of a Healthcare organisation [1,2].

To shorten the path to transparency and interoperability of these solutions, the scientific community is conducting various studies to ensure technologic architectures that are sufficiently capable of meeting the requirements [3,4], with generalised implementations for certain medical specialties and hospital entities, looking for ways to ensure the high precision of AI-based systems [5]. Generalisation is based on the fact that different implementations require similarities in a set of restrictive and/or temporal clinical rules [6]. One of the critical aspects of adopting this technology is the creation and integration of prediction and optimisation models automatically and semi-autonomously, i.e., how models from different tools can be integrated into an ABI system.

In this article, we propose a robust microservices architecture. This architecture aims to streamline the deployment of intelligent models while seamlessly integrating them within the ABI system. By leveraging microservices, we aspire to enhance the efficiency, scalability, and adaptability of these models, thereby contributing to the realization of a harmonious and proficient Healthcare ecosystem.

The structure of this document begins with a brief introduction to the problem involving deploying and integrating intelligent models in ABI systems. Next, an explanation of ABI systems and a contextualization of them in Healthcare. The third section contains the proposed architecture as well as its technical approaches and advantages. Finally, the conclusion and future work represent the last part of the paper that aims to conclude based on what has been developed in the paper and the next steps.

2. Adaptive Business Intelligence

Adaptive Business Intelligence (ABI) is an area that combines forecasting and optimisation techniques to build automatic learning systems for decision-making. The aim of ABI is to provide organisations with the ability to make decisions by converting raw data into knowledge and considering the changing environment. ABI systems are designed to solve two fundamental questions [7,8]:

- *What is likely to happen in the future?*
- *What is the best decision right now?*

To create an ABI system, the following processes are essential (figure 1): prepare and analyse the raw data, develop a prediction model based on the data analysis, develop an optimisation model to recommend the best solution, and develop an adaptability component so that the models can be adjusted in the face of changes in the environment [7].

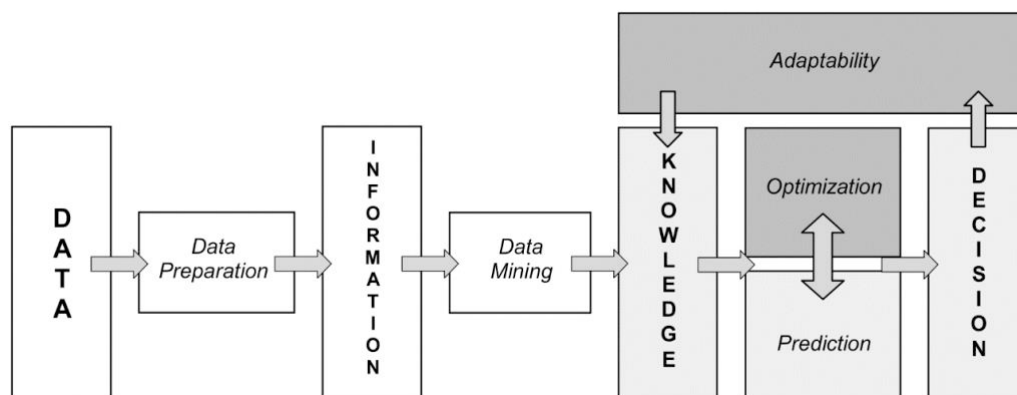

Fig. 1. Adaptive Business Intelligence processes [7]

2.1. ABI in Healthcare

In the context of the Healthcare, in many cases, especially in Intensive Care Units (ICUs), decision-making needs to be a quick and effective process because choosing the wrong decision or delaying a decision are factors that can determine the patient's current state, in some cases determining their life or death.

Intensive Care Medicine (ICM) is a complex field that requires exceptional expertise in several areas, including pathophysiology, therapeutics, and technology. The aim of ICM is to support and restore the vital functions of critically ill patients to save their lives. There are critical moments when first responders need to administer medication, and it is in these moments that decision-making is extremely important [9–11].

Diabetes, for example, has been a growing concern in recent years, with a significant increase in the number of diagnoses and related deaths. This is largely attributed to our dependence on sugar consumption. The existence of problems of this kind, i.e., diseases that can be determined in advance, leads to the need to develop, and utilise systems that can predict these diseases [12].

Efficient resource planning in hospitals has become a major responsibility for the management of various clinical units. This is especially true in ICUs, where patients require constant observation and monitoring. The high costs incurred by hospitalised patients and the optimisation of these resources are crucial. Another example is the problem of overcrowding in hospitals, making hospital beds one of the most sought-after resources. Predicting the occupancy rate of these beds is therefore an extremely important aspect of hospitalisation planning and management [13,14].

The management of hospital waiting lists is another crucial aspect that has a direct impact on the quality of healthcare services provided to patients. By effectively managing human, material and financial resources, hospitals can ensure that patients receive the best possible service [15].

In the recent years, research has focused on each of these topics. By analysing the recent articles, we verify that most of the research develop predictive models [10–14,16] and some optimization models [9,15] but none carried out the deployment and integration of the model in the ABI system. In this way, we note that the deployment and integration of the intelligent models is not usually investigated, and there is an opportunity to deepen our knowledge of it.

3. Architecture Proposal

To harmonize the automatic or semi-automatic integration of intelligent models in an ABI system, we propose a microservices-based architecture.

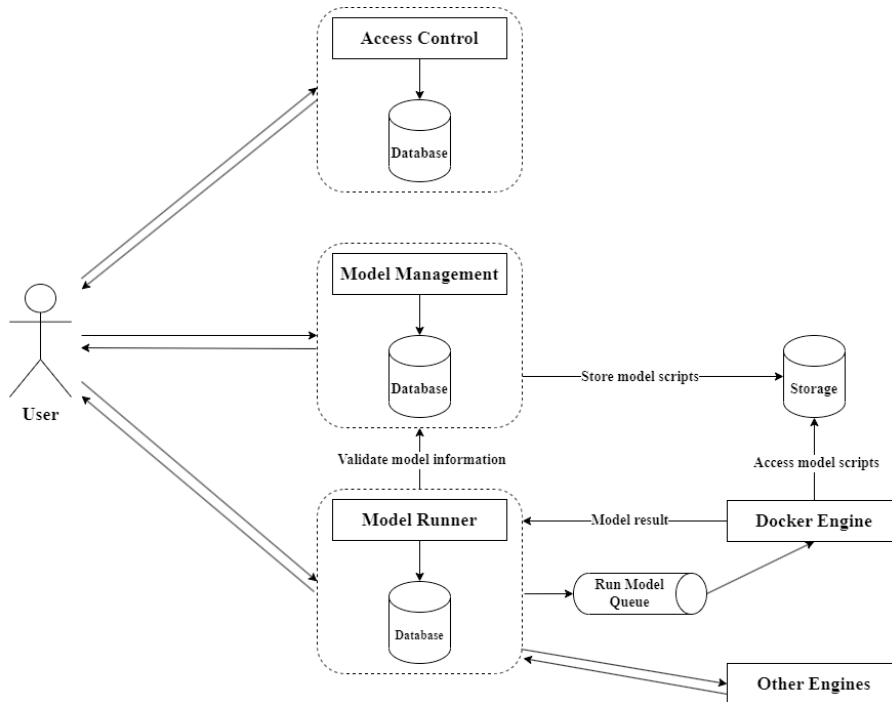

Fig. 2. Microservice architecture proposal for deploying and integration of intelligent models in ABI systems

The choice of a microservices architecture is due to its adaptability to the different technologies, i.e., each microservice is built independently in the most appropriate technology for its function. Since intelligent models can be built in different programming languages and tools, microservices can be specialized in certain technologies to run certain models.

The proposed architecture (figure 2) has three core microservices:

- **Access Control:** This service manages all users of the system. It can create, update, and delete users, as well as map which microservices they have access to. Its main objective is to authenticate the user in the system by generating tokens that are then requested when another microservice in the architecture is used.
- **Model Management:** This service manages all models in the system. It is through this service that the authenticated user knows which models belong to them. The user can add models, as well as update and delete the models they have added. When adding a model, the user must specify its metadata, i.e., all the features it uses, the technology it was built with, the libraries used, and upload the model files. Finally, the user must select the engine in which the model should be run.
- **Model Runner:** This service is responsible for mapping models to be run in the corresponding engine and for storing all information about model runs, i.e., when a model was requested to run, the values of the features, when the model finished running, and the result that was returned.

The architecture also includes a microservice for running most models:

- **Docker Engine:** This microservice is one of the engines suggested by the architecture for running models. Docker has an API that can be used to automate various processes. In the case of running models, the metadata provided by the user can be used to create a Dockerfile, build it, and create a container in detach mode automatically without interrupting the processes of the other microservices. Since the Dockerfile build process can take some time, a message queue is used to inform the user that the model has been started and to notify him when it has finished

running. This approach can support most models, but it can take some time to get the final result of the model as it works with a message queue.

However, this microservice may not be able to handle models from some technologies or may present some limitations in more complex models. In these situations, the architecture can be scaled by creating a new microservice to run other models. These microservices are called engines and the user must specify the engine they want their model to run on. This information is stored in Model Management and then mapped by Model Runner when the user starts a request to run the model.

3.1. Authentication and data management

Authentication in the architecture is decentralized. It is based on tokens that are orchestrated through all the microservices. The core of this mechanism is found in the Access Control microservice, which is responsible for validating the user and generating the tokens.

The authentication flow is as follows: The user sends a request to the Access Control service to validate their credentials and request a token; The Access Control service validates the user's credentials and return a token; The user then uses the token to access the other microservices.

The token contains the user's authentication information, such as their username and id, and the microservices they have access to. The token is validated using the same algorithm in all the microservices. This means that once a user has a token, they can use it in all the microservices, even if the Access Control service is unavailable.

The data flowing in the system is managed by each core service by having an independent database. This approach is essential to the integrity of each microservice, as it prevents changes made to one microservice from affecting the others. Independent databases not only optimize system speed, but also increases scalability by minimizing interdependencies.

In the event of a microservice encountering a problem or failure, the operational continuity of other microservices is generally not affected. This is because each microservice is self-contained and does not rely on the others for its data. The structural autonomy conferred by independent databases is fundamental to making the architecture robust and resilient.

3.2. Advantages of microservices

Microservices architecture presents several benefits. It allows diverse technologies in different services. If one component fails, the entire system remains unaffected, ensuring resilience. Scaling is efficient, targeting only the necessary services. Deployment is simplified, enabling independent updates. This architecture aligns with organizational structures, reducing the need for extensive teams working on a single codebase. Furthermore, microservices allow easy integration of services and smooth updates [17,18].

In the case of our architecture, using microservices can offer the following benefits:

- **Integration of intelligent models:** Each microservice can be implemented using the most appropriate technology for its function, so we can use microservices to integrate intelligent models from different programming languages and tools.
- **Scalability:** Microservices can be scaled independently, so we can scale the architecture up or down as needed to meet the needs of the organization.
- **Reliability:** Each microservice is self-contained, so if one microservice fails, the others generally will not be affected. This improves the overall reliability of the architecture.
- **Maintainability:** Microservices are smaller and more modular, so they are easier to maintain than monolithic architectures. This can reduce the cost and time of maintenance.

4. Conclusion and Future Work

The proposed project addressed the pressing challenge of deploying and integrating intelligent models within Adaptive Business Intelligence (ABI) systems in the healthcare sector. These systems are crucial for managing the vast and intricate healthcare data landscape while aiding healthcare administrators in making informed strategic decisions. The need for AI-based solutions has fuelled research in this domain, emphasizing the importance of efficient model deployment and integration.

The proposed architecture represents a significant step forward in this pursuit. By leveraging microservices, we have strived to enhance the efficiency, scalability, and adaptability of intelligent models in ABI systems and consequently, to improve the efficiency and effectiveness of healthcare services. This architecture offers several key advantages, including modularity, ease of maintenance, and the ability to seamlessly integrate various AI tools and models. Additionally, it aligns well with the growing trend of containerization and cloud computing, enabling ABI systems to harness the full potential of modern technology.

Moreover, our architecture provides a flexible framework that can be adapted to specific medical specialties and diverse hospital entities, fostering generalization while accommodating variations in clinical rules.

Acknowledgements

This research was funded by Fundação para a Ciência e Tecnologia, within the Project Scope: UIDB/00319/2020.

References

- [1] Ashfaq A, Nowaczyk S. Machine learning in healthcare - a system's perspective 2019.
- [2] Lopes J, Braga J, Santos MF. Adaptive Business Intelligence platform and its contribution as a support in the evolution of Hospital 4.0. *Procedia Comput Sci* 2021;184:905–10. <https://doi.org/10.1016/j.procs.2021.04.016>.
- [3] Aceto G, Persico V, Pescapé A. Industry 4.0 and Health: Internet of Things, Big Data, and Cloud Computing for Healthcare 4.0. *J Ind Inf Integr* 2020;18:100129. <https://doi.org/10.1016/j.jii.2020.100129>.
- [4] Tian S, Yang W, Grange JM Le, Wang P, Huang W, Ye Z. Smart healthcare: making medical care more intelligent. *Global Health Journal* 2019;3:62–5. <https://doi.org/10.1016/j.glohj.2019.07.001>.
- [5] Wang F, Casalino LP, Khullar D. Deep Learning in Medicine - Promise, Progress, and Challenges. *JAMA Intern Med* 2019;179:293. <https://doi.org/10.1001/jamainternmed.2018.7117>.
- [6] Futoma J, Simons M, Panch T, Doshi-Velez F, Celi LA. The myth of generalisability in clinical research and machine learning in health care. *Lancet Digit Health* 2020;2:e489–92. [https://doi.org/10.1016/S2589-7500\(20\)30186-2](https://doi.org/10.1016/S2589-7500(20)30186-2).
- [7] Michalewicz Z, Schmidt M, Michalewicz M, Chiriac C. Adaptive Business Intelligence. 2006.
- [8] Lopes J, Guimarães T, Santos MF. Adaptive Business Intelligence: A New Architectural Approach. *Procedia Comput Sci* 2020;177:540–5. <https://doi.org/10.1016/J.PROCS.2020.10.075>.
- [9] Passos M, Duarte J, Silva A, Manuel M, Quintas C. Decision models on therapies for intensive medicine. *Procedia Comput Sci* 2022;210:230–5. <https://doi.org/10.1016/J.PROCS.2022.10.142>.
- [10] Quesado I, Duarte J, Silva A, Manuel M, Quintas C. Data Mining Models for Automatic Problem Identification in Intensive Medicine. *Procedia Comput Sci* 2022;210:218–23. <https://doi.org/10.1016/J.PROCS.2022.10.140>.
- [11] Tavares I, Duarte J, Peixoto H, Silva A, Manuel M, Quintas C. Association Models for Relating Problems with Semiologic Data in Intensive Medicine. *Procedia Comput Sci* 2022;210:224–9. <https://doi.org/10.1016/J.PROCS.2022.10.141>.
- [12] Vaz MJ, Lopes J, Peixoto H, Santos MF. Predictive Analytics to support diabetic patient detection. *Procedia Comput Sci* 2022;201:690–5. <https://doi.org/10.1016/J.PROCS.2022.03.092>.
- [13] Macedo R, Barbosa A, Lopes J, Santos M. Intelligent Decision Support in Beds Management and Hospital Planning. *Procedia Comput Sci* 2022;210:260–4. <https://doi.org/10.1016/J.PROCS.2022.10.147>.
- [14] Peixoto D, Barbosa A, Peixoto H, Lopes J, Guimarães T, Santos M. Predictive analytics for hospital inpatient flow determination. *Procedia Comput Sci* 2022;210:254–9.

- <https://doi.org/10.1016/J.PROCS.2022.10.146>.
- [15] Fernandes I, Lopes J, Braga J, Santos MF. Applying optimization models in the scheduling of medical exams. *Procedia Comput Sci* 2022;201:696–701. <https://doi.org/10.1016/J.PROCS.2022.03.093>.
 - [16] Faria M, Barbosa A, Guimarães T, Lopes J, Santos M. Predictive analytics for hospital discharge flow determination. *Procedia Comput Sci* 2022;210:248–53. <https://doi.org/10.1016/J.PROCS.2022.10.145>.
 - [17] De Lauretis L. From monolithic architecture to microservices architecture. *Proceedings - 2019 IEEE 30th International Symposium on Software Reliability Engineering Workshops, ISSREW 2019* 2019:93–6. <https://doi.org/10.1109/ISSREW.2019.00050>.
 - [18] Blinowski G, Ojdowska A, Przybyłek A. Monolithic vs. Microservice Architecture: A Performance and Scalability Evaluation. *IEEE Access* 2022;10:20357–74. <https://doi.org/10.1109/ACCESS.2022.3152803>.