



TU1406

COST ACTION

Quality specifications for roadway bridges,
standardization at a European level

WG5

TECHNICAL REPORT
DRAFTING OF GUIDELINE/
RECOMMENDATIONS OF
COST ACTION TU1406

Authors: Vikram Pakrashi, Helmut Wenzel, Jose Matos, Joan Casas, Alfred Strauss, Irina Stipanovic, Rade Hajdin, Amir Kedar, Guðmundur Guðmundsson, Maria-Pina Limongelli, Yiannis Xenidis, Sandra Skaric Palic

March 2019

ISBN: 978-1-910963-33-3

Authors: Vikram Pakrashi, Helmut Wenzel, Jose Matos, Joan Casas,
Alfred Strauss, Irina Stipanovic, Rade Hajdin, Amir Kedar, Guðmundur
Guðmundsson, Maria-Pina Limongelli, Yiannis Xenidis, Sandra Skaric Palic

WG5 SUMMARY

Context	1	The need of maintenance management framework is felt strongly by all stakeholders of road bridges, especially as infrastructure ages, with increased exposure to natural and man-made load effects and the lack of adequate funds.
	2	While the overall objectives of maintenance management are similar, the detailed methods in practice vary widely. The detailed methods should be modified as little as is reasonably possible when a new maintenance management framework is established. This is with a view to not burden the existing and limited human, technical and financial resources available in different networks and countries.
	3	Standardization is a slow process and appropriate pathways of sustained engagement with relevant organisations can lead to success.
Challenges	4	There is still inadequate sharing of data, information and experience around the EU in road bridge maintenance and management.
	5	Different networks and countries have information obtained at varied levels of details and complexity for a bridge network to take decision and consequently an agreed framework has to recognise and integrate such hierarchical levels of information of different quality and quantity.
	6	Lack of uniformity around technical vocabulary and definitions for road bridge maintenance management is a hindrance to developing a uniform framework in EU.
Benefits	7	This is an ideal time to close the gap between research and practice of road bridge maintenance and management in EU by developing a common framework and working towards future standardisation.
	8	A data and evidence-based decision making around road bridge maintenance and management is envisaged for future.
	9	Markers considering different aspects of benefit and public good is envisaged to influence decision making further (e.g. environmental and social indicators) robust and sustainable.
	10	A pan-EU body should be established with key stakeholders to engage with the development of such uniform guidelines and integrating it to national and EU normative documents and decision-making process.
Working Group 5: Guidelines and Recommendations		

INDEX

1. INTRODUCTION TO THE ACTION 9

- 1.1. Action Overview 9
- 1.2. COST TU1406 WG5 Composition 9
- 1.3. Overview of Working Groups (WGs) 10
- 1.4. Background and Motivation 10
- 1.5. Knowledge Gap 11

2. OBJECTIVES OF THE ACTION 12

- 2.1. Objectives of WG1 12
- 2.2. Objectives of WG2 12
- 2.3. Objectives of WG3 12
- 2.4. Objectives of WG4 13
- 2.5. Objectives of WG5 13
- 2.6. Objectives of WG6 13
- 2.7. Objectives of IAB 13
- 2.8. Objectives of Innovation Sub-Committee 14

3. SUMMARY AND CONCLUSIONS OF WORKING GROUPS (WGS) 14

- 3.1. WG1 - Performance Indicators 14
- 3.2. WG2 - Performance Goals 15
- 3.3. WG3 - Establishment of a Quality Control Plan 17
- 3.4. WG4 - Implementation in a Case Study 27
- 3.5. Interaction with Industry Advisory Board 28
- 3.6. Interaction with Normative Bodies 28
 - 3.6.1. Overview 28
 - 3.6.2. Discussion around Sustainability and Indicators 28
 - 3.6.3. Discussion around Standardization 29
 - 3.6.4. Context around Existing Activities of some Standardization Bodies 31
- 3.7. Interaction with Road Bridge Asset Stakeholders 32
- 3.8. Commentary on Dissemination 32
- 3.9. Main Guidelines and Recommendations 32

4. EXAMPLES OF QC FRAMEWORK AND IMPLEMENTATION OF THE SPIDER TOOL 33

- 4.1. Implemented Case Study 1: Girder Bridge in Dobříš, Czech Republic 33
- 4.2. Implemented Case Study 2: Arch Bridge, Guarda District, Portugal 35
- 4.3. Implemented Case Study 3: Steel Truss Bridge, Israel 40

5. CONCLUSIONS AND FUTURE WORK 44

- 5.1. Summary of Guidelines and Recommendations 44
 - 5.1.1. Key Guidelines and Recommendations from WG1 44
 - 5.1.2. Key Guidelines and Recommendations from WG2 44
 - 5.1.3. Key Guidelines and Recommendations from WG3 44
 - 5.1.4. Key Guidelines and Recommendations from WG4 45
- 5.2. Assumptions and Challenges 47
- 5.3. Ongoing Work 47
- 5.4. Vision for Future 47

6. TERMINOLOGY 48

- 6.1. Context to terminology 48
- 6.2. Activity in COST TU1406 on understanding terminology 48
- 6.3. Key Definitions and Terminology 48

7. REFERENCES 50

APPENDIX

Appendix A 51

Appendix B 61

1. INTRODUCTION TO THE ACTION

1.1. ACTION OVERVIEW

This report assimilates and synthesizes the work carried out by COST Action TU1406 - Quality specifications for roadway bridges, standardization at a European level (www.tu1406.eu) in various Working Groups. The objective is thus not to create new information but to highlight and emphasize the key recommendations and guidelines developed in various working groups. The recommendations and guidelines are not prescriptive, but suggestive and allows a diverse range of methodologies already in operation in various bridge networks to align to it. The need for a homogeneous approach for the maintenance and management of road bridges in EU, while acknowledging the disparate processes of such management is key to understanding this report.

To address this need, interdisciplinary work has been carried out in participating countries in this Action over the last 4 years and insight, solutions and impact have been created around performance indicators, assessment and performance. Eventually, a method of assessing roadway bridges under various performance criteria is presented and several examples are created. **Figure 1** provides a schematic to this context.

Working Group 5 (WG5) attempts to synthesise this cross-disciplinary evolution of the topic through TU1406 and link it with industrial experience in various countries and attempt to create an impact on normative documents. Additionally, it provides pathways for future development of this topic after the completion of the action.

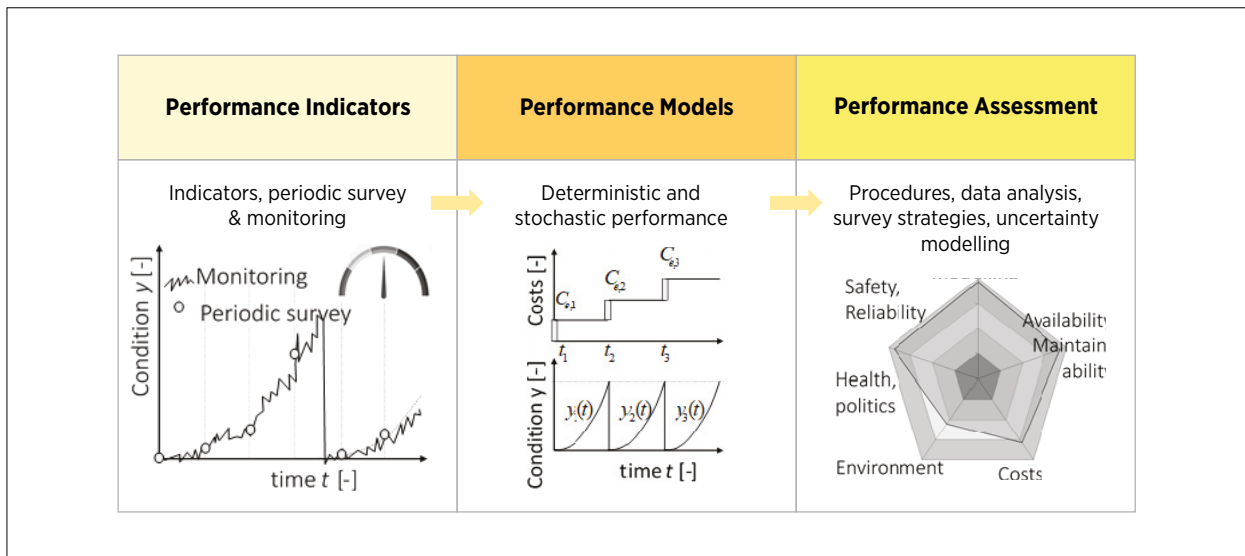

Figure 1. Conceptual idea of managing road bridges via a) performance indicators, leading to b) performance models, which is subsequently mapped to c) performance assessment based on multiple criteria relevant for the relevant stakeholders.

1.2. COST TU1406 WG5 COMPOSITION

WG5 comprises of a healthy mix of academics and industry-personnel, along with representation from various owners of bridge infrastructure networks. The WG has attempted to strike a gender balance and cover a range of ages from various countries, including those outside the EU. A summary of this composition is provided below in **Table 1**. There is significant overlap in membership with other WGs in this Action. This mix of members allowed for a robust interaction and discussion at the level and width of expertise at which TU1406 was proposed.

Attribute of WG5	Number
Total Members	65
Gender Balance (Male: Female)	52:13
Percentage of Members with a PhD	66.2%
Academia-Industry Balance (Ratio)	46:19
Early Career Investigators	8
Graduation Time-Period of Members	1969-2017
Co-Membership with other WGs	WG1:29, WG2:26, WG3:27, WG4:34
Number of Countries Represented	29
Number of Countries outside COST	Canada, Chile, China, Colombia, India, Iran, Nicaragua, USA: 8 nos.

Table 1. Composition of TU1406 WG5

1.3. OVERVIEW OF WORKING GROUPS (WGS)

The following technical WGs were active in COST TU1406:

- **WG1:** Identification and insight into key indicators of performance of roadway bridges [led by *Alfred Strauss*]
- **WG2:** Investigation and understanding of performance goals [led by *Irina Stipanovic*]
- **WG3:** Establishment of a Quality Control plan [led by *Rade Hajdin*]
- **WG4:** Implementation of Case Studies [led by *Amir Kedar*]
- **WG5:** Drafting of Guidelines and Recommendations [led by *Vikram Pakrashi*]

In addition, there is a **WG6:** Dissemination [led by *Guðmundur Guðmundsson*], an **Industry Advisory Board** [led by *Niels Peter Hoj*] and an **Innovation Sub-Group** [led by *Maria Pina Limongelli* and *André Orcesi*].

Summary of findings from each WG is provided later in the report.

The scientific focus of the Action is centred in the production of a guideline for the establishment of QC plans for roadway bridges across Europe. In this context, this Action deals with recent developments on bridge safety, maintenance and management, according to a life-cycle outlook, aiming to define a standardized procedure for performance assessment as well as for the establishment of performance goals in order to accomplish a pre-specified service level. Moreover, it is intended to demonstrate the applicability of developed guideline, and other recommendations, with case studies. The overall interaction of Working Group 5 (WG5) in relation to COST TU1406 is presented in **Figure 2**.

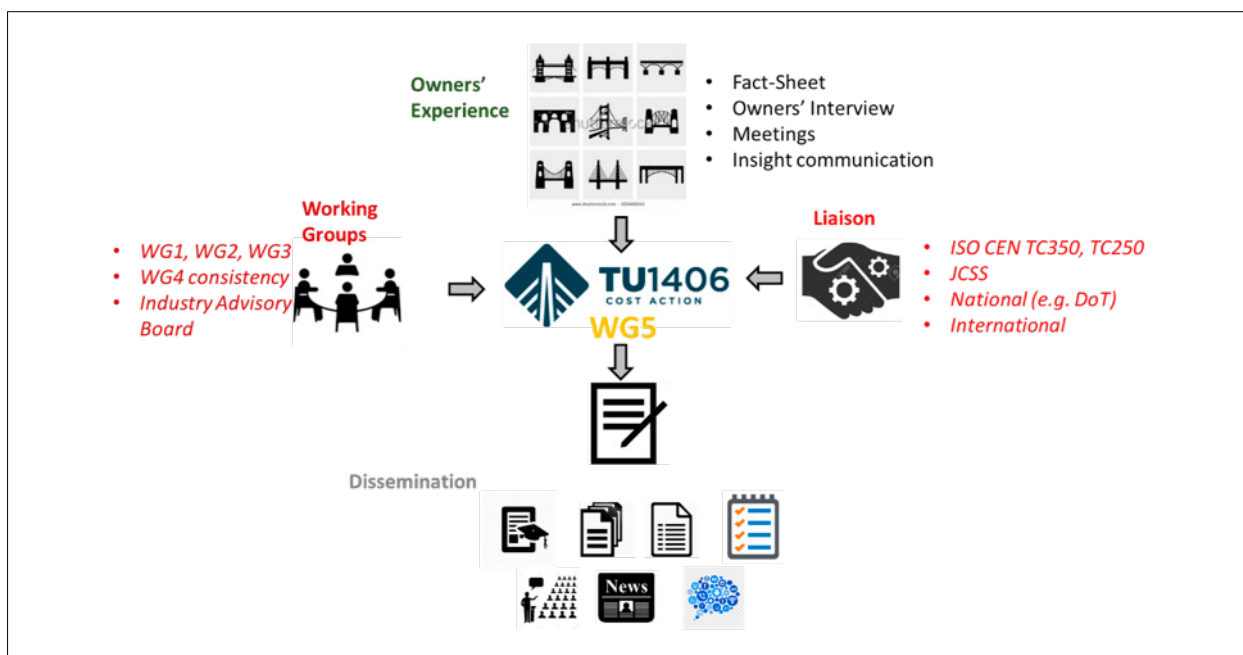

Figure 2. Overall structure of COST TU1406 and the position of WG5 in it in terms of activities and contribution from relevant stakeholders of road bridge infrastructure assets.

1.4. BACKGROUND AND MOTIVATION

In engineering, quality control (QC) relates to the development of systems to ensure that products or services meet or exceed, the expectations and needs of users and the wider community. For road infrastructure, asset management and QC are two sides of the same coin. Though they belong to the domain of public service, their management mechanism can be conducted by the state or under a private public partnership. In both cases, there is an increasing need of developing strategies to ensure the quality of the entire system, with the aim of reducing the risk of unexpected costs.

Road asset management is a task of great responsibility since it involves vital assets to the community. Free movement of goods is a cornerstone of the EU treaty and requires healthy road bridges. On the other hand, the communication via road bridges extends far beyond just economic context, since they allow us to reach out workplaces, access services, schools and to connect us with the community we live in. An efficient transportation network is thus essential for the modern society from the economic, societal and environmental point of view.

Roadway bridges, together with other roadway structures, such as tunnels, are the most critical components of road infrastructures. Throughout their life, they require regular maintenance actions whose costs are generally supported by the operator. Accordingly, it becomes important to define strategies to maximize the societal benefits, derived from the investment made in these assets. This investment should be planned, effectively managed and technically supported by appropriate management systems.

There exists a challenge for operators to manage road infrastructures under their responsibility in an efficient way, meeting the present and future needs of the community they serve. The infrastructure is distressed as they grow old in many countries, and there are not adequate funds anywhere in the world to address a problem of this scale in its entirety. Under such circumstances, maintenance and management strategies of road bridges under constraints of resources and the needs of safety and serviceability form a major challenge.

Some of the main outcomes from the correct implementation of these strategies for roadway bridges management are: (i) an improved user satisfaction, by improving the quality of provided service; (ii) an improved sustainable performance; (iii) a guarantee of a pre-specified safety level; (iv) an optimized return of investment; (v) a long-term planning and reliable performance; (vi) an improved risk management and (vii) creation of or contribution to normative documents.

For this purpose, the authorities need to produce an asset management plan, which should not only define the goals to be achieved by exploiting the roadway bridge network, but also identify the investment needs and priorities based on life cycle cost criteria. In addition, a proper condition assessment of these assets must be conducted to support the decision-making process regarding their preservation. A set of maintenance operations, carefully planned and executed at proper time, is then established through this process. This allows to risk reduction related to further deterioration, minimization of costs and ensuring the quality of delivered service.

Several roadway bridge management systems exist at a country-wide level or at a more local level. While they present significant commonality in their architectural framework, several differences exist, especially about the condition assessment procedures. These differences can lead to different decisions on maintenance actions.

Within the roadway bridge management process, the identification of maintenance needs is more effective when developed in a uniform and repeatable manner. The process can be established by evaluating appropriate performance indicators and improving the planning of maintenance strategies.

Therefore, a discussion at a European networking level through COST TU1406, seeking to achieve a standardized approach in this subject, brings significant benefits. The standardized approach unifies several formats of maintenance management in different networks and countries but allows them to be implemented in the format that they are already operational.

In this context, a first step is the establishment of specific recommendations for the assessment of roadway bridges in the form of identification of methods used for the quantification of performance indicators. A set of reference time periods for these assessment actions are also relevant here. A second step is the definition of standardized performance goals. Finally, a guideline for the establishment of QC plans in roadway bridges can be developed, along with benchmark implementation examples. The importance of advanced deterioration prediction models is emphasized here as a key influencing factor. Moreover, the concept of sustainable roadway bridge management, involving the evaluation of environmental, economic and social performance indicators during the whole life cycle, is also highlighted.

TU1406 has a high societal relevance and brings together a collaborative network of several stakeholders, namely, partners from research and practicing community, aiming to joint efforts to build consensus on this subject. Multidisciplinary and complementary expertise covering a wide range of topics from visual inspection, on-site testing, numerical modelling, asset management and sustainability are considered. The collaborative dialogue developed in the process amongst researchers, engineers and owners and supported through networking, capacity building and training activities in COST TU1406 thus forms an invaluable reference point in the evolution of bridge assessment in EU.

1.5. KNOWLEDGE GAP

During the implementation of asset management strategies, maintenance actions are required in order to keep assets at a desired performance level. In case of roadway bridges, specific performance indicators are established for their components. These indicators can be qualitative or quantitative and can be obtained during principal inspections through a visual examination, non-destructive tests or a temporary or permanent monitoring system. Obtained indicators are compared with performance goals, in order to evaluate if the quality control plan is accomplished. It is verified that there is a large disparity in Europe regarding the way these indicators are quantified and how such goals are specified. Therefore, this Action aims to bring together, for the first time, both research and practicing community in order to accelerate the establishment of a European guideline in this subject. It will be also analysed new indicators related to sustainable performance of roadway bridges.

The knowledge gaps identified by COST TU1406 are as follows, all in the context of varied implementation procedures of road bridge assessment in EU: Lack of

- a. Clear guidelines in terms of understanding and defining **Performance Indicators**
- b. Clarity around **Performance Goals**
- c. Guidance around **Quality Control** plans
- d. **Benchmark** example for implementing such quality control and assessment plans
- e. **Recommendations** that can link to operational guidance and normative documents

2. OBJECTIVES OF THE ACTION

The main objective of the Action is to develop a guideline for the establishment of QC plans in roadway bridges, by integrating the most recent knowledge on performance assessment procedures with the adoption of specific goals. This guideline will focus on bridge maintenance and life-cycle performance at two levels: **(I) Performance Indicators, (II) Performance Goals**. By developing new approaches to quantify and assess the bridge performance, as well as quality specifications to assure an expected performance level, bridge management strategies will be significantly improved, enhancing asset management of ageing structures in Europe.

To reach the main general aim stated above, the following specific objectives with tangible deliverables have been considered:

- i.* **systematizing knowledge** on QC plans for bridges, which will help achieve a state-of-art report with appropriate performance indicators and respective goals;
- ii.* **collecting and contributing** to up-to-date knowledge on performance indicators, including technical, environmental, economic and social indicators;
- iii.* establishing a wide set of **quality specifications** through the definition of performance goals, aiming to assure an expected performance level;
- iv.* developing **demonstrative examples** for practicing engineers on the assessment of performance indicators as well as in the establishment of performance goals, subsequently to be integrated in the developed guideline;
- v.* creating a **database** from COST countries with performance indicator values and respective goals, which can be useful in future;
- vi.* developing a webpage with information about the Action and its participants, as well as **archived information** from presentations at training schools, workshops and conferences, e-lectures and technical reports;
- vii.* supporting the development of **technical/scientific committees**;
- viii.* engaging in focused **dissemination activities** like Short-Term Scientific Missions (STSM), training schools and other teaching activities (e.g. e-lectures) for practicing engineers and researchers, regular workshops, a conference and special sessions at international conferences.

The overall objectives of each WG is presented next.

2.1. OBJECTIVES OF WG1

The goal is to explore the performance indicators of bridge structures through international research cooperation, capturing the mechanical and technical properties and its degradation behaviour, already partly covered by code specifications. Considerations also include: natural aging, quality of the material; service life design methods; sustainable indicators; environmental, economic and social based indicators and performance profiles. The final result is the implementation of a performance indicator database for Europe with flexibility to accommodate country-specific requirements.

Specific objectives are the characterization of bridge performance indicators, which can address:

- i.* the safety: the load factor, the reliability index to ULS;
- ii.* the serviceability: the condition index, the reliability index to SLS;
- iii.* the availability, robustness;
- iv.* the costs: the total LCC, values related to durability aspects; and
- v.* aspects of environmental efficiency: CO2 foot-print.

2.2. OBJECTIVES OF WG2

The objective is to provide an overview of existing performance goals for the indicators previously identified in WG1 and to develop technical recommendations which will specify the performance goals. These goals will vary according to technical, environmental, economic and social factors. The performance goals will vary according to technical, environmental, economic and social factors.

Specific objectives are:

- i.* linking performance indicators to performance goals
- ii.* developing a framework for key performance indicator (KPI) assessment
- iii.* extending the bridge management thought process to wider goals like social, economic and environmental performance
- iv.* development of a tool and demonstration of its performance for the framework developed

2.3. OBJECTIVES OF WG3

Based on the results of WG 1 and WG 2 as well as on survey of existing approaches in practice, the objective of this WG is to provide a methodology with detailed step-by-step explanations for establishment of QC plans for different types of bridges. The QC plan has to relate performance goals, which are user/society related, e.g.: Traveling time; Traffic allowance; Safety level; Comfort/Serviceability.

Specific Objectives of WG3 are:

- i.* based on results from WG1 and WG2, as well as on a survey of existing approaches in practice extending the bridge management thought process to wider goals like social, economic and environmental performance

- ii.* establish a QC framework with detailed step-by-step explanations
- iii.* QC planning for different types of bridges addressing the dynamics and uncertainty of the processes that may significantly compromise bridge performance.

2.4. OBJECTIVES OF WG4

In WG4 implementation of the developed framework in WG1,2 and 3 will be carried out through case studies covering a range of bridges from different countries. A series of benchmarks will be developed in WG4 in the process.

Specific objectives of WG4 are:

- i.* implementation of developed framework to benchmark case studies and creation of a database
- ii.* adaptation and application of some of the performance indicators identified in WG1 for a set of roadway bridges
- iii.* comparison of the indicators with specific goals identified in WG2
- iv.* application of the QC plan for the bridge using recommendations from WG3

2.5. OBJECTIVES OF WG5

WG5 drafts the guideline/recommendations by synthesizing the works from other WGs for the entire Action. These guidelines for a systematic maintenance and management of highway bridge assets and acknowledge the variation of philosophical, technical and implementation methodologies throughout the EU, with the expectation that the delivered framework will be scalable and portable for standardised implementation in existing or new infrastructure networks.

Specific objectives of WG4 are:

- i.* summarizing the key guidelines and recommendations from all WGs into a single approach for implementation by road bridge owners and managers
- ii.* liaising with and documenting the experience of bridge owners and managers of different countries in EU
- iii.* liaising with normative bodies and creation of a pathway for the results of the action to influence the process of standardization
- iv.* create an environment for continuing the advancement established in COST TU1406 after the completion of the action.

2.6. OBJECTIVES OF WG6

The aim of this WG is to disseminate all results which were obtained in all the other WGs. Dissemination consists in establishing liaisons with existing national and international associations in close connection with WG5, participation and contribution in conferences, working groups and publication in journals. Also, this group will be responsible to continuously update the website as well as all the other dissemination frameworks.

The target groups and end users who will exploit the outcome of this Action are:

- i.* public/private owners, as their assets will be maintained in an upscale level;
- ii.* operators, as standardized procedures for reducing maintenance costs, guaranteeing the same quality-level;
- iii.* design and consultant engineers, as the assessment of roadway bridges performance will be established in a uniform way, according to the developed guideline;
- iv.* equipment and software companies, as a new perspective will be given, regarding the most suitable equipment and software for the assessment of roadway bridges;
- v.* academics and research engineers, as they will take an advantage of their involvement in the guideline preparation;
- vi.* students, as they will benefit from COST tools (e.g. training schools) and from the contact with different stakeholders involved in this Action;
- vii.* relevant European, international and national associations, with which the main outcomes of this Action will be shared;
- viii.* standardization bodies and code writers, which will benefit from the developed guideline.

2.7. OBJECTIVES OF IAB

The Industry Advisory Board consists of:

- João Amado, Direction of Asset Management, Infraestruturas de Portugal, Portugal
- Ralph Holst, Deputy Head of Section B4 - Maintenance of Engineering Structures Federal Highway Research Institute (BAST) Germany
- Niels Peter Høj, CEO, Chief Specialist, HOJ Consulting, Switzerland
- Giel Klanker, Senior Advisor, Rijkswaterstaat Major Projects and Maintenance, the Netherlands
- Poul Linneberg, Chief Specialist, Operation and Maintenance & Steel, COWI A/S, Denmark

The main objective of the IAB is to review the outcome and deliverables from COST TU1406 and comments based on the applicability in practice for the industry. Each WG technical report is reviewed by the IAB. Web-meeting and subsequent individual contributions are used for this purpose.

2.8. OBJECTIVES OF INNOVATION SUB-COMMITTEE

This sub-committee brings together several researchers and organisations in a collaborative fashion to provide a commentary on the needs and priorities of the industry in road bridge management around issues, indicators and equipment.

Specific objectives are:

- i. establishing and identifying a common motivation of the collaborating participants
- ii. development of an Indicator Readiness Level (IRL) framework, built upon the Technology Readiness Level (TRL) and subsequent ranking of the maturity level of performance indicators at the research stage in the context of COST TU1406.
- iii. Identifying and sharing knowledge on recent innovations around relevant technologies for non-destructive testing techniques and structural health monitoring.

3. SUMMARY AND CONCLUSIONS OF WORKING GROUPS (WGS)

This section presents the summary of results, conclusions and recommendations of various WGs in COST TU1406. Details and commentary around each recommendation is available in the final report of the respective WGs.

3.1. WG1 – PERFORMANCE INDICATORS

Key Documents: 1. Technical Report; 2. Database

Link: www.tu1406.eu/working-groups/wg1-performance-indicators

Using information available in two survey phases, WG1 explores key performance indicators of road bridges through international research cooperation. The indicators capture the mechanical and technical properties and its degradation behaviour, which are currently partly covered by code specifications. Considerations include natural aging, quality of the material; service life design methods; sustainable indicators; environmental, economic and social based indicators, performance profiles. A performance indicator database for Europe is implemented with flexibility to accommodate country-specific requirements. The indicators address: the **(a) safety**, **(b) serviceability**, **(c) availability**, **(d) costs**, and **(e) aspects of environmental efficiency**.

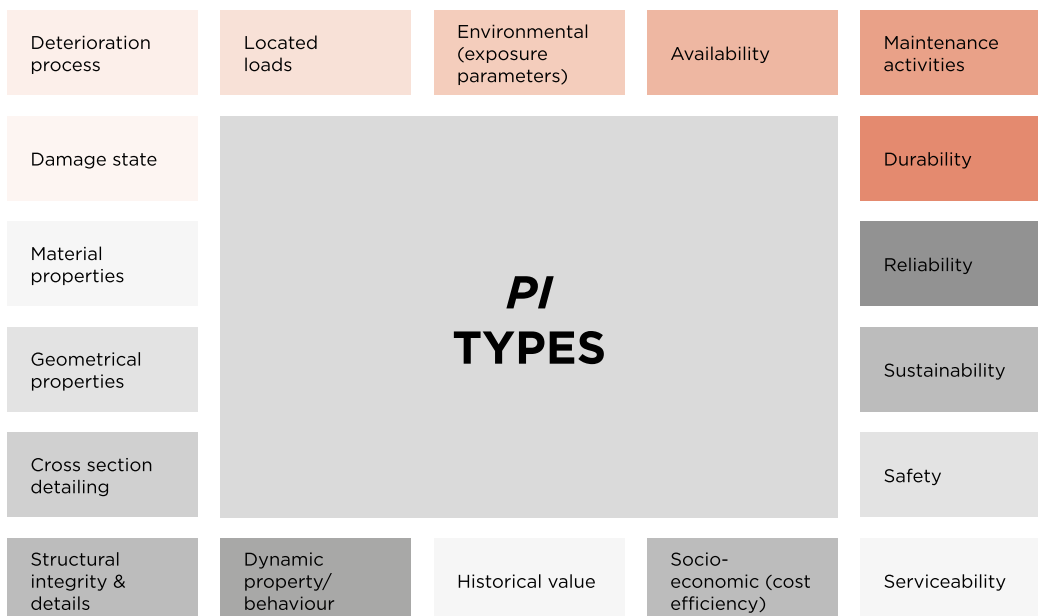

Figure 3. Presents the types of performance indicators considered in this WG.

To guarantee a satisfactory bridge performance throughout the entire lifetime, it is important to define the framework within which the asset management framework is operating on. The success of efficiency of this framework is significantly dependent on its design and how it fits with the diverse requirements and responses of the bridge stock under consideration. Several factors may be at play here: safety, stability, serviceability, functionality, durability, cost-effectiveness and impact to the environment.

Existing literature indicate that socio-economic factors on this topic can be a key effect in their efficient management. Details are provided in WG1 final report. A holistic perspective taken for bridge management from the points of view of (i) environment, (ii) economic and (iii) social is extremely important. Once a performance indicator is established, different combinations of varied procedures and weighting factors can provide invaluable insights and the development of combined PI from simple PIs, which are typically related to one characteristic on the structure. A PI is related to different factors such as safety, user comfort and environment.

Bridge performance in Europe is dominated by PI supported by operators' database, which are set by surveying documents related to bridge maintenance. Nevertheless, collection and analyses on available research-based PI is becoming more competitive since they can offer more accurate and objective information, which encourages further research to improve performance assessment methods mainly those supported by monitoring techniques. In spite of the existence of the above-mentioned guidelines, discrepancies in terms of concepts and terminologies between them exist and therefore, a comprehensive and holistic approach to this problem is proposed as bridge management supported by PI. WG1 reviews existing information and (i) identifies, (ii) evaluates and (iii) quantifies PI for road bridges. Further sustainable trends and development towards a unified database of PI are also given, benefiting significantly from the rapidly advancing evolution of Inspection and Structural Health Monitoring (SHM). The Performance Goals (PG) and PI are introduced first and discussed at different levels within bridge management, mainly at the (i) component, (ii) system and (iii) network level. This follows the reversed order of the process recommended generally in RAMS analysis (MAHBOOB AND ZIO, 2018), which defines the end functions through setting goals and subsequently developing more detailed indicators. This is often also combined with performance-based design and inversed verifications are made during this process. The European PI database is reviewed and presented by grouping them into (i) operators' PI database and (ii) research-based PI database.

A categorization of PI is presented and described, according to the outlined performance levels, at the level of Operational Database, more work is necessary to identify key performance indicators. Further extension of Operational Database with the Research-based one should help in the following two main tasks:

- a. to select the most important Performance Indicators for achieving Performance goals that are crucial for optimal Quality Control Plan within bridge management;
- b. to allocate them with appropriate weights (importance level).

In order to select the most important Performance Indicators the following steps should be followed:

1. Define crucial Performance Goals (e.g.: safety, serviceability, reliability, durability, availability, maintainability etc.)
2. Categorise Performance indicators in relation to Performance Goals (at different levels: component, system, network; taking into account different aspects: technical, sustainability, socio-economic etc.)
3. The following questions should ideally considered for a PI:
 - a. Is it measurable?
 - b. Is it quantifiable?
 - c. Is target value available?
 - d. Is it valid for ranking purposes?
 - e. Does it allow decision with economic implications?

The overall database created includes the most important indicators for achieving the goals crucial for optimal quality control.

3.2. WG2 – PERFORMANCE GOALS

Key Documents: 1. Technical Report 2. Web-Based Tool:

Link: www.tu1406.eu/working-groups/wg2-performance-goals

The connection of Performance Indicators to Performance Goals is made here at component, system and network levels, as indicated by **Figure 4**.

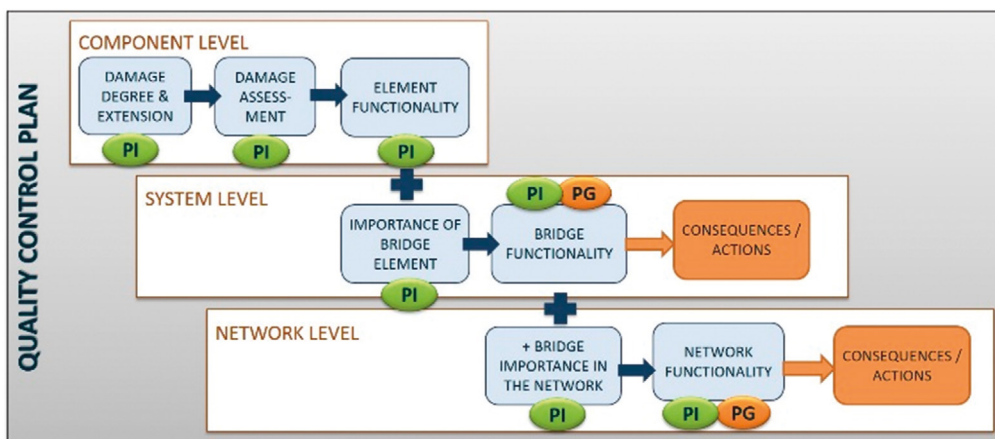

Figure 4. Assessment procedure from component to the system and network level based on the Performance Indicators (PIs) and Performance Goals (PGs).

Multiple bridge performance goals are set as multi-objective system, taking into account different aspects of bridge and network performance. In COST TU1406 approach, we have five performance aspects: A. Reliability; B. Availability; C. Economy; D. Environment; E. Traffic Safety. Multi-criteria decision-making (MCDM) provides a systematic approach to combine these inputs with benefit/ cost information and decision-maker or stakeholder views to rank the alternatives. A large disparity, however, exists within Europe regarding the way performance indicators are quantified and with respect to the specification of goals. Based on these ideas, and the need for assessing bridges for various operational conditions, WG2 develops a web-based tool (maut.shinyapps.io/application_of_maut/) titled Multi-Attribute Utility Theory (MAUT) by using the R Utility package (Reichert et al., 2013). This is a multi-objective report.

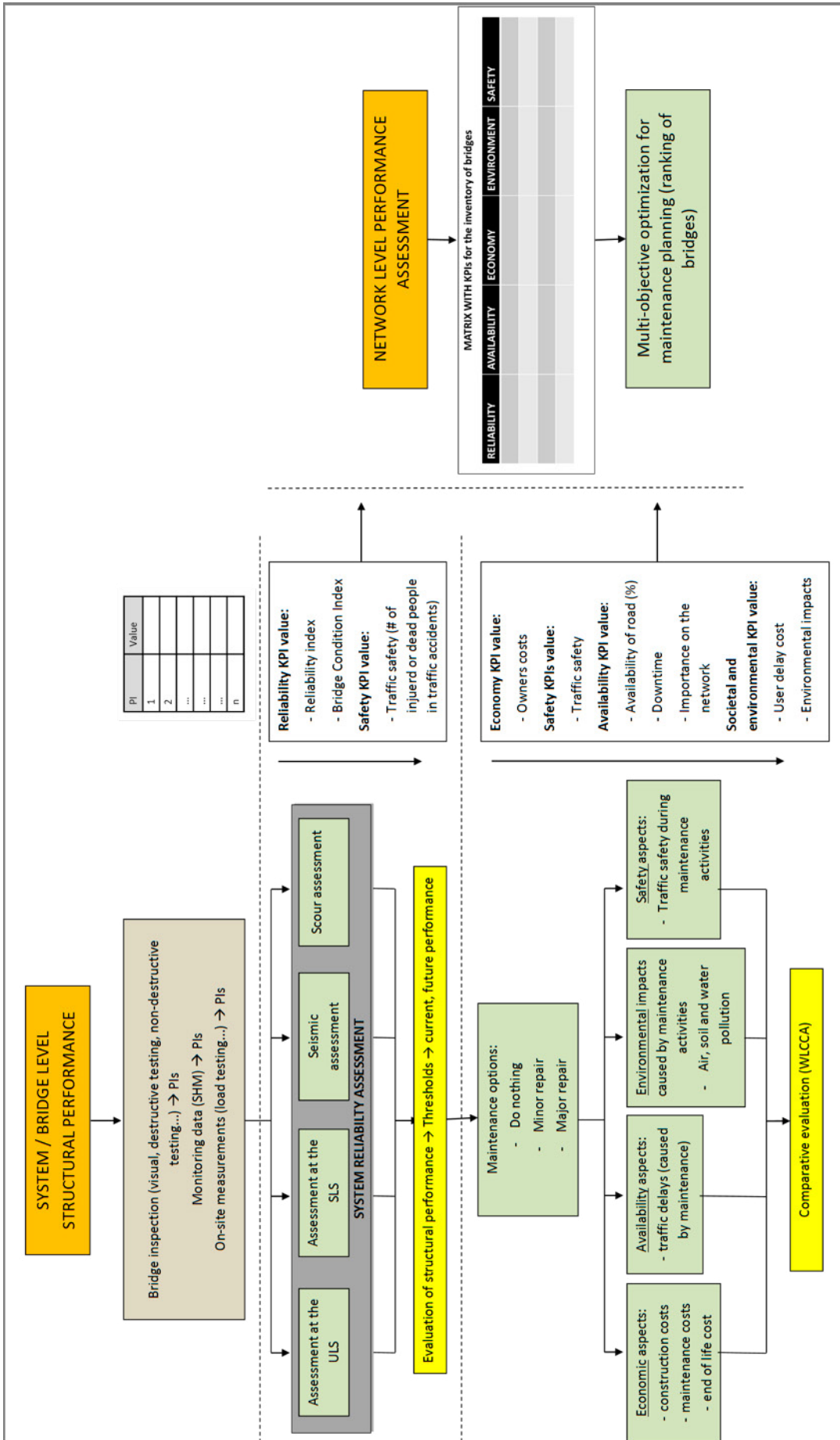

Figure 5. A MAUT Assessment Framework

Figure 5 presents an example of one such assessment. As the focus on an efficient delivery of network performance increases, so does the interest in the relations between societal goals, performance indicators for both the road network and bridges or bridge elements. The implementation of asset management should increase the integration of network and structure performance requirements. In doing so, bridge managers and road agencies now face a number of challenges, these include:

- How to quantify the performance goals and related performance indicators?
- How to translate from network to the object level and vice versa?
- How to establish a complete set of performance indicators?

Network or even societal goals tend to be rather broad in their definition. Furthermore, there is often no exclusive relationship between performance indicators set at a lower level and goals at a higher level. An important notion is that in many countries, the main focus of bridge management is still the condition assessment of the particular objects or elements thereof.

WG2 gives an overview of performance goals at different levels, from high-level strategic decisions to low-level, system-specific requirements. It has also attempted to explain how other performance aspects, like traffic safety, availability, economy, environmental and societal impacts could be quantified and used for the multi-objective bridge performance goals assessment. Future developments can concentrate on the unification of:

- Standardization of the assessment procedures,
- Collection of PIs and quantification of KPIs,
- Development of maintenance optimization tools which can be applied in practice.

3.3. WG3 – ESTABLISHMENT OF A QUALITY CONTROL PLAN

Key Documents: 1. Technical Report

Link: <https://www.tu1406.eu/working-groups/wg3-establishment-of-a-qc-plan>

The decision-making process regarding the maintenance interventions (including rehabilitation and replacement) of existing bridges differs somewhat from the one regarding the construction of new bridges. These differences can be summarized as follows:

- Existing bridges already contribute to economy and maintenance interventions on them may result in their total or partial closure that incurs user costs. Opposite to design/construction of new bridges where these costs are not of pivotal importance, they need to be considered in cost/benefit analysis of maintenance interventions.
- In light of user costs, extending the service life of existing bridges can be beneficial. In most cases it is better to invest into diagnostics of existing bridges, which may render their fitness for purpose. The safety and serviceability margins that apply in design need not to be applied for existing bridges, as they reflect the uncertainties in construction process. These uncertainties may be significantly reduced by simple measurements and sample testing and consequently the safety and serviceability margins can be narrowed.
- The design requirements are closely related to the design service life. If an existing bridge needs to be in service for a significantly shorter time, these requirements can be adapted accordingly.
- Extending the service life of an existing bridge is also environmentally beneficial. The consumption of resources for diagnostics actions cannot be compared to one of a replacement.
- It should be considered however, that the existing bridges are exposed to higher loadings than those considered when they were designed (i.e. due to traffic volume and traffic load increase) and this needs to be duly considered. Additionally, the climate change or new insight with in geology and weather patterns can render existing structures unsafe.

These aspects need to be adequately considered in decision-making process with regards to existing bridges and in preparation of quality control plan. There is no generally accepted definition of quality, a) fitness for purpose and b) a degree to which a set of inherent characteristics of a product or service fulfills requirements are usually considered. A broader view of quality will also include the service delivery process (costs, societal and environmental aspects), whereby apart from customers' satisfaction further performance goals related to economic efficiency, environmental friendliness and social responsibility become a requirement. This broader definition is adopted by COST TU 1406.

The term "quality control" can have two meanings. To control is both to verify, check or inspect but also to command, direct and rule. The former definition implies a passive task in which the quality is checked and reported. The latter definition is a broader one that includes undertaking all necessary action to ensure quality. Consequently, the quality control plan specifies all activities and tools, needed to ensure quality. In case of road infrastructure, the quality control plan defines the extent and the interval of inspections or investigations and data necessary to estimate key performance indicators (KPI) and forecast their future development.

Quality control plan also includes decision model that suggest maintenance action based on the forecast of key performance indicators. In this sense the quality control plan overlaps with the Strategic Asset Management Plan (SAMP) and Asset Management Plan (AMP) as defined in ISO 55000.

When a new bridge is constructed and handed over from a contractor to an owner, it is assumed that it is built/designed according to the valid codes at that time and that all relevant loading cases and traffic demand are considered. The quality of a bridge at this point of time is at an adequate level since all the acceptance criteria e.g. structural safety, serviceability and traffic safety, are fulfilled. The acceptance criteria can be also extended to durability i.e. to fulfilment of structural safety, serviceability and traffic safety criteria during the whole service life. These criteria are broadly referred to as requirements, goals or standards that a bridge needs to meet, and in some countries, they are additionally verified in a "zero inspection", prior to commissioning.

Inspection/monitoring is performed on a bridge to determine if it meets the desired/required quality which can differ from the one at the time of commissioning. This quality assessment is performed in a variety of manners, either visually or with an equipment. If the results show unacceptable variations of quality, in-depth investigations or interventions may be triggered. The results obtained in inspection/monitoring process here represent a basis for adequate decision making on actions to ensure the required quality on a long-term. Planning is thus essential to establish a schedule, scope and optimal times between inspections.

Bridge Management also includes maintenance planning & execution. Short-term planning is based on in-depth investigations and structural analysis and include detailed specification of interventions that are to be implemented shortly thereafter. Mid- to long-term maintenance planning is a process, in which different intervention scenarios are developed. Here, there is a possibility to choose among preventative, corrective and operational actions. The interventions are not specified in detail and their costs are often approximate estimates backed by experience, to avoid unpleasant financial surprises. Early planning allows to choose the optimum time for interventions and reduce long-term costs.

The general approach is presented in **Figure 6**, where it is assumed that an inspection is performed “today”. The results from the inspection revealed damages that in conjunction with the actual loads lead to worsening of safety and serviceability levels but still meet the requirements for existing structures. For mid- to long-term maintenance, planning forecasts for serviceability and safety are performed predicting that serviceability criterion will be not fulfilled at the time instance marked “Tul”. This means that the intervention needs to be executed no later than at that point in time, if serviceability requirements are not to be violated. However, it may well be that a scenario that includes an intervention at the time instance “Top”, has lower long-term costs than the one with the intervention at the time instance “Tul”. Thus, an extremal criterion related to long term costs have to be included to obtain an optimal solution in a decision-making approach. **Figure 6** does not show any intervention after “Tul”, but normally the ensuing interventions are considered in estimation of long-term costs.

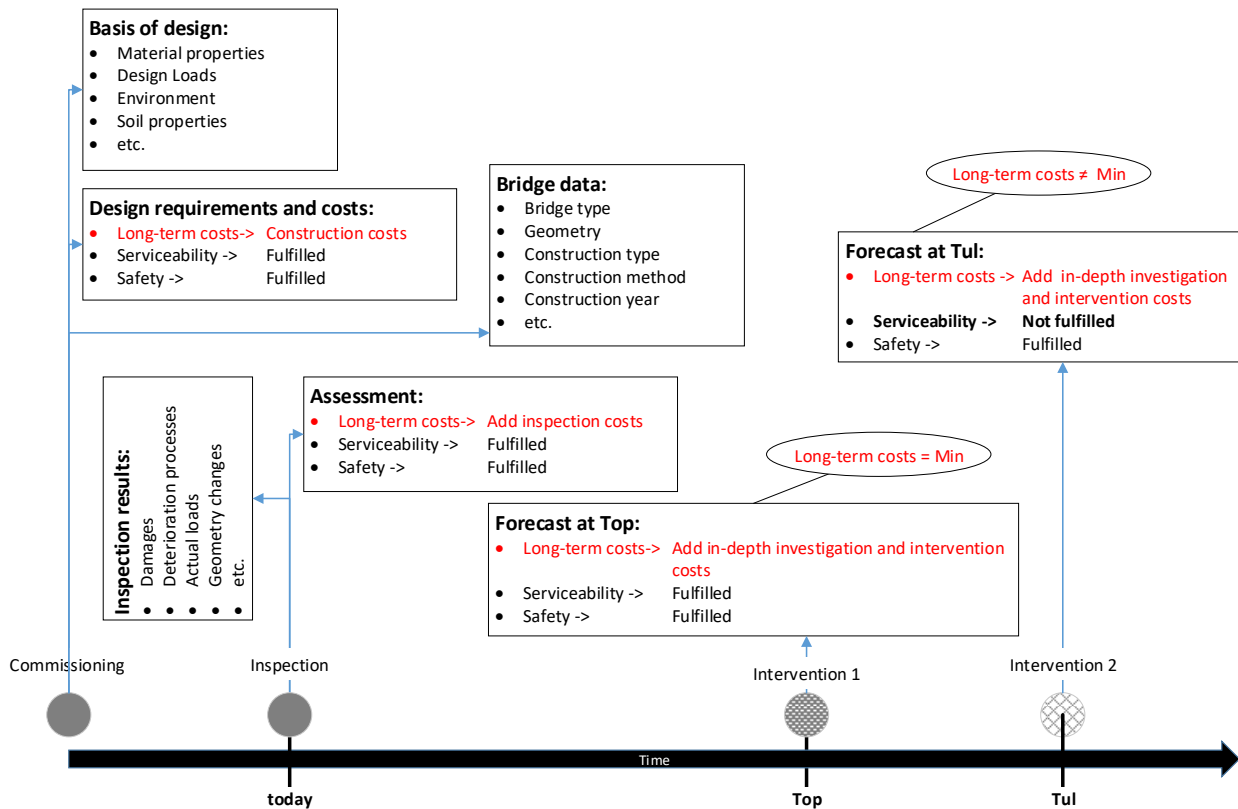

Figure 6. General approach of mid to long-term maintenance planning.

For existing bridges, the obvious choice for the Key Performance Indicators (KPI) are a) safety and b) serviceability. This may be combined with other indicators like durability, stability, costs and functionality. In COST TU1406 the proposal for KPI (qualitative, between the ordinal scale of 1-5) is based on the Dutch approach (Rijkswaterstaat, 2012) and defined as:

1. Safety, Reliability and Security (**S, R, S**) - a combined KPI;
2. Availability and Maintainability (**A, M**) - a combined KPI;
3. Economy € (i.e. Costs);
4. Environment (**E**)
5. Health and Politics (**H, P**) - a combined KPI.

While safety is directly considered, the serviceability is not. Serviceability is included in Availability. The overall performance is represented by a ‘Spider Net’ diagram (**Figure 7**). The larger the area in the diagram enclosed by the KPI values, the better is the bridge performance and KPIs values in the green area are desirable. This format is applicable for a single or a collection of bridges. An adaptation of this diagram was eventually used for the final implementation of COST TU1406.

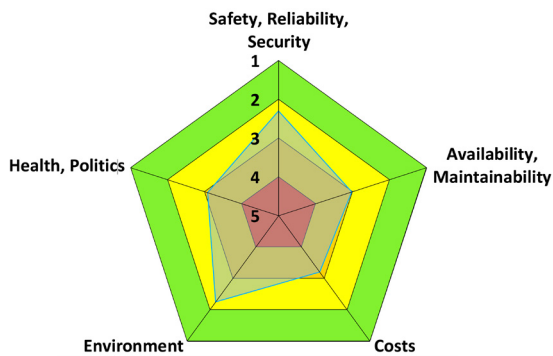

Figure 7. A 'Spider Diagram' for bridge assessment.

Evaluation of KPIs from performance indicators (PIs) still require several discussions to resolve all outstanding issues around them and aspects like Reliability and Availability seem to be overlapping sometimes. Furthermore, some KPIs are difficult to assess at least on a bridge level, notably KPIs Health and Politics but also the Maintainability.

The Maintainability is the ease with which a product can be maintained in order to repair damages or their cause, repair or replace faulty components without having to replace still working parts and prevent unforeseen maintenance measures. This can be understood as a design aspect and it is covered within Economy. The Security is degree of protection against vandalism and it is similar to the Maintainability.

The current framework developed in TU1406 considers the following KPI with associated definitions:

- i. **Reliability** - the probability that bridge will be fit for purpose during its service life. It is the complement to the probability of structural failure (i.e. safety), operational failure (i.e. serviceability) or any other failure mode.
- ii. **Availability** - the proportion of time a system is in a functioning condition. It is not reliability-related disruption of bridge users but originates from planned maintenance interventions (e.g. additional travel time due to an imposed traffic regime on bridge).
- iii. **Safety** - related to minimizing or eliminating the harm to people during the service life of a bridge. The loss of life and limb due to structural failure is not included (see Reliability).
- iv. **Economy** - related to minimizing long-term costs and maintenance activities over the service life of a bridge. Herein the user costs incurred due to detours and delays are not included.
- v. **Environment** - associated with minimizing the harm to environment during the service life of a bridge

Within a QC framework, the KPIs will be evaluated for different maintenance scenarios (based on inspection/investigation or prediction), looking for the most feasible one. KPIs of Availability, Economy and Environment can be only reasonably applied as a function of time. Damage processes for bridges are defined as those which acting singly or in a combination, have a detrimental effect on a bridge and information on them are crucial for performance prediction, planning of preventive maintenance and planning of eventual rehabilitation. Damage processes are gradual and observable (using a proper inspection strategy) or non-observable (handled by a proper maintenance strategy). Both inspection and maintenance strategies can be optimized through better information on damage processes, graded with respect to their nature, intensity, extent and location and considering damage type, cause and affected material.

Impact of natural hazards on bridges is yet to be included in the future BMS. Older bridges are often not or not adequately designed for natural hazards and it is likely that the climate change has an adverse impact on frequency and intensity of gravitational hazards. A risk-based maintenance planning can be applicable for natural hazards and related failure modes and corresponding probabilities of failure must be defined through probabilistic characterisation. Bridges should be examined for different frequency and intensity of hazard events. Based on this analysis, the probability of failure can be assessed as a function of hazard intensity. Flood Hazard and local scour are considered in COST TU1406. Understanding of possible consequences due to a damage processing is critical for correct diagnosis and observations around them may be qualitative or quantitative.

A Performance Indicator (PI) measures the fitness for purpose of a bridge. For example, a crack width > 0.4 mm can be a sign of reinforcement yield due to insufficient resistance or overloading. While an observation presents simply a fact, a PI is already an interpretation of its impact on a bridge performance. It should be noted that some observations are symptoms, i.e. they have no direct impact on static (i.e. snapshot) KPIs (Reliability and Safety). If symptoms are interpreted in a dynamic context, i.e. for planning purpose, they may with very few exceptions have direct impact on relevant KPIs (Availability and Economy). WG1 presents more than 700 terms (shortened to 385), later clustered and homogenized and can be related with PIs. Four categories are considered in PI in the common framework for QCPs: a) Design & Construction, b) Observations, c) Damage Processes and their d) symptoms.

Performance assessment practices differs significantly from country to country but relies significantly on visual inspections, leading to a qualitative indicator (e.g. condition rating/state/ class), which is a vague measure for the deviation of the inspected bridge from the "as new" condition. The direct assessment of safety and serviceability is regarded as not cost efficient since it is commonly assumed that such assessment requires in-depth material investigation and structural analysis. The documents around safety and serviceability for individual bridges are usually archived and in general not easily accessible. During the service life, inspections are performed with no consideration of safety and serviceability information produced during the design phase. There is a substantial gap during the service life of a bridge, in which decisions are made based on qualitative indicators, that are sometimes unrelated to the key concerns of bridge owners: safety and serviceability.

In most countries, performance assessment is supported by databases, in which the results of inspections are stored, sometimes in great detail. The information from design phase i.e. critical load combinations, safety factors, assumed traffic loads is usually not stored in these databases. In some road agencies, there are load rating software that facilitate evaluation of special transports, but it is rarely used in conjunction with inspection results. The relevant information on safety and serviceability is often not stored in the database after maintenance interventions. With access to even preliminary information, approximate screening studies can be efficiently carried out on estimates on safety and serviceability.

Modern codes define both safety and serviceability in terms of reliability index, related to the target probability aligned to the fitness of a bridge for purpose during its service life, which is the definition adopted by COST TU1406. Evaluation of reliability can be economically beneficial if existing bridges can still be used without restrictions. While assessing the reliability of existing bridges can be tedious and complex, based on experience and available data, a simplified reliability assessment can be performed which can be adequate for assessment. Relevant failure modes here can be defined based on design documentation and vulnerable zones are to be considered for the failure modes. Vulnerable zones are those segments and/or elements of a bridge structure in which damages have the largest impact

on safety and serviceability and can be related to several failure modes. The general framework ontology for the most important entities are presented in **Figure 8** as a so-called Entity Relationship Diagram (ERD). Here, the “crow foot” symbolizes one-to-many relationship whereas the “crow foot with a circle” stands for one-to-zero or one-to-many relationships.

The method is applicable for all bridge types (‘Structure’) and the all element types (‘Components’, e.g. beams, decks, piers). In the entity group Inventory, there can be other entities apart from “Construction type” such as “Geometry” and “Construction method”. The entity “Design and construction” include several other entities related to original design such as construction year, design loads, soil characteristics, etc. The entity “Observation” comprises damages, geometry changes, etc.

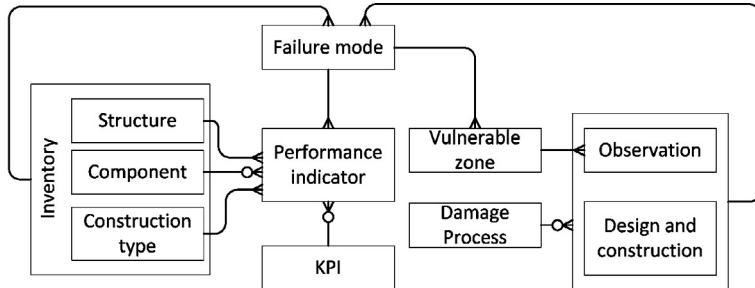

Figure 8. The ontology of a Quality Control Framework

The diagram can be interpreted as follows: There is an observation (e.g. a crack) with a certain property (e.g. crack width), on an element of a certain type (e.g. a beam), with the location in a vulnerable zone that is related to a specific failure mode of a structure (e.g. a girder bridge). With an influence of other data (e.g. the construction year), this observation will have an impact on a defined KPI expressed by a performance value. The entity level defines the impacted level (e.g. a structure).

The damage process is derived based on observations and on original design and construction data. It governs the development of the observed damages in the future and allows the forecast of performance indicators. In relation to vulnerable zones, there are some historical design concepts (e.g. Gerber hinge in girder/frame bridges) that do not perform well and should be evaluated carefully due to its conceptual weakness. On the other hand, standard sub or super-structure elements have some usual modes of failure, which should be checked and marked (**Figure 9**). Bearings, concrete h

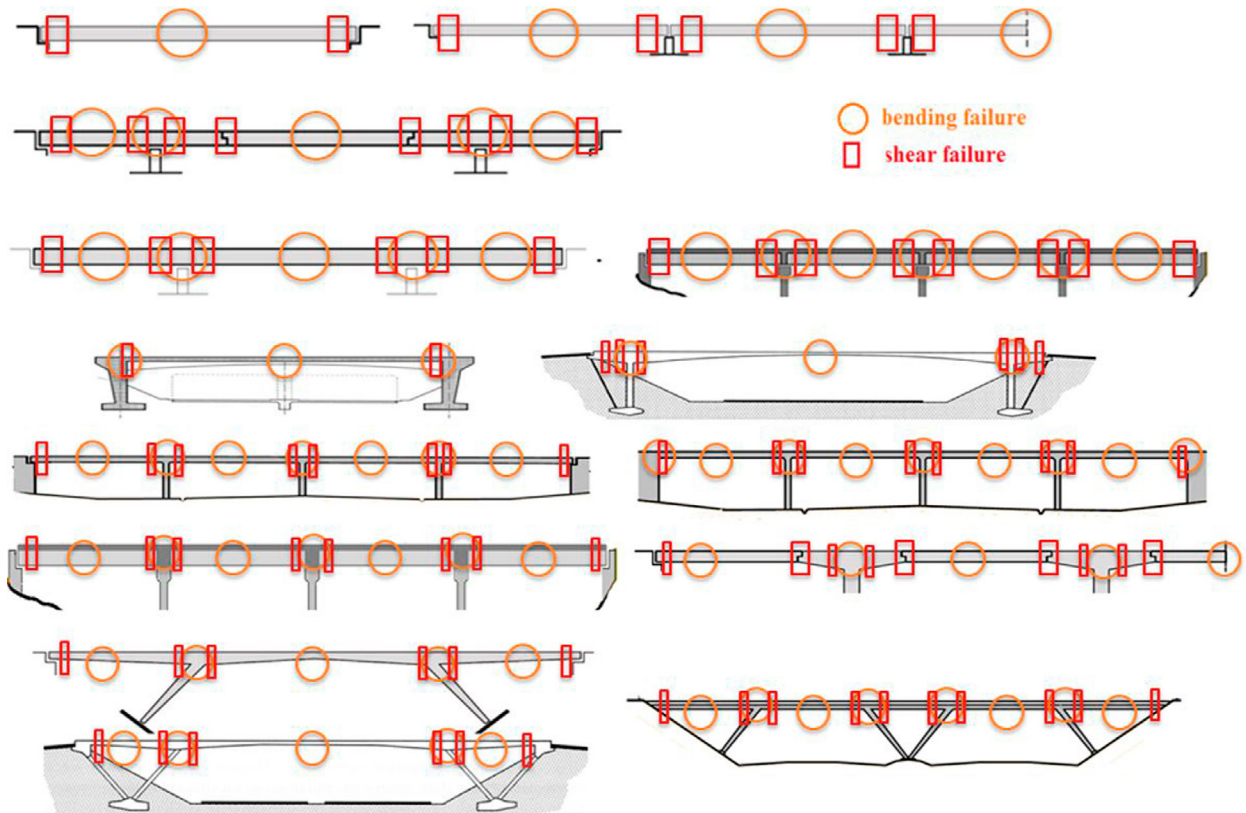

Figure 9. Marking vulnerable zones and failure modes in bridges.

Based on the framework ontology (Figure 8), an example of a performance evaluation is presented in Figure 10. Necessary information and related connections have been structured in a table, where the key point is the relationship between failure modes/vulnerable zones. So far, within BMSs this information has been considered as “engineering judgement” and is not related to various bridge types and crucial observations. It is on a judgement of an Owner/Operator to assess this impact in terms of urgency of intervention, as well to predict a time interval in which the related KPI value will reach a predefined threshold for an intervention. Bayesian nets may be applied to evaluate the value of Reliability KPI and the final report of WG3 of COSTS TU1406 provides details around such methodology.

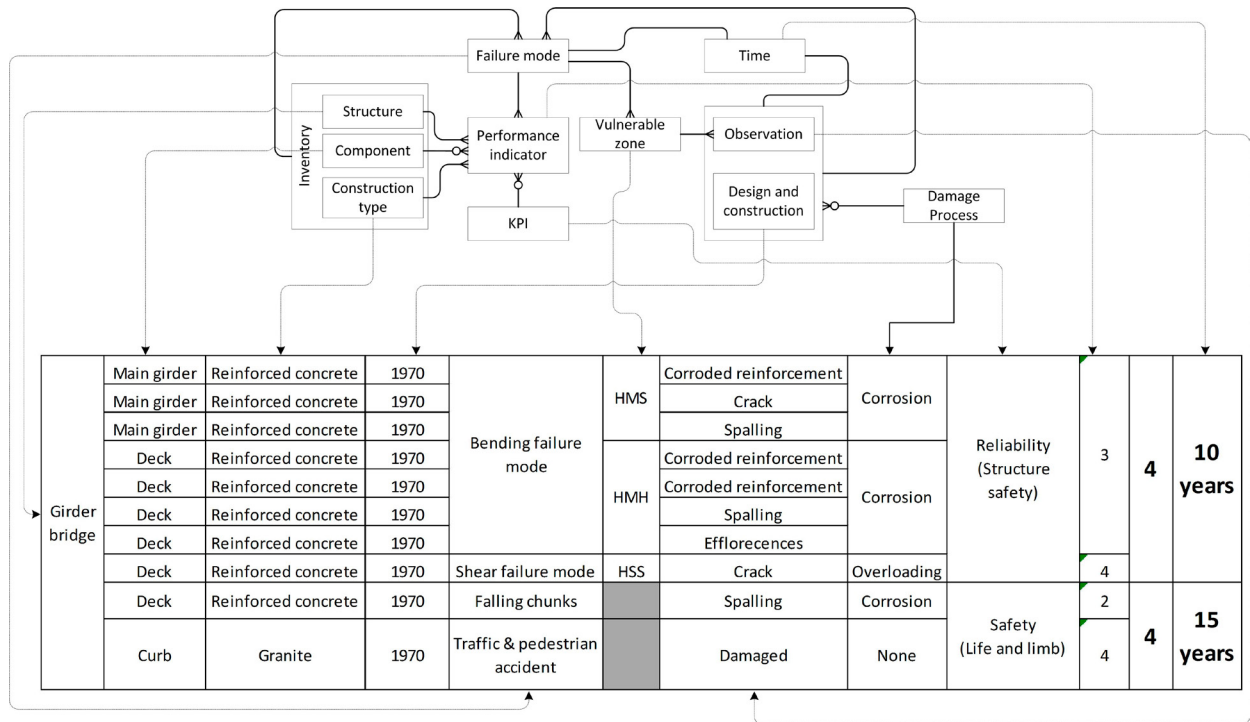

Figure 10. Example of derivation of KPIs from PIs.

In COST TU1406, all KPI are scaled from 1-5, where 1 is the best value and 5 is the worst. Some KPIs such as Availability, Environment and Economy need to be expressed in native units and then scaled from 1-5. Availability is the proportion of time a system is in a functioning condition. In this case the value can be only 0 or 1 for each time instant. Availability can be measured by additional travel time (not trivial and may need validated traffic models) for vehicle categories, which can be subsequently monetized as user costs. When models or information are not available, a qualitative Availability value, based on the importance of the road and possible alternative routes can be established. A similar reasoning applies for Economy. The KPIs are thus normalized here. The KPIs can be conveniently visualized using a ‘spider diagram’, as presented before. Each KPI is given on a separate axis, and when their development over time is of interest, the time axis can be appended orthogonally on the plane of the diagram. In this manner, a “performance tube” can be generated (Figure 11). there can be more than one Reliability axis i.e. that failure modes related to either serviceability or safety can be separately assessed. This is convenient for the case when analyzing decisions on maintenance and would like to account both for the failures due to severe deterioration and the failures due to a hazard. In general, the necks in the diagram represent the time intervals of low performance, whereas the areas with “full” pentagon cross-section are the time periods of high performance. Alternatively, volume between the “full” pentagon and the “performance tube” can be regarded as performance deficit that is to be minimized.

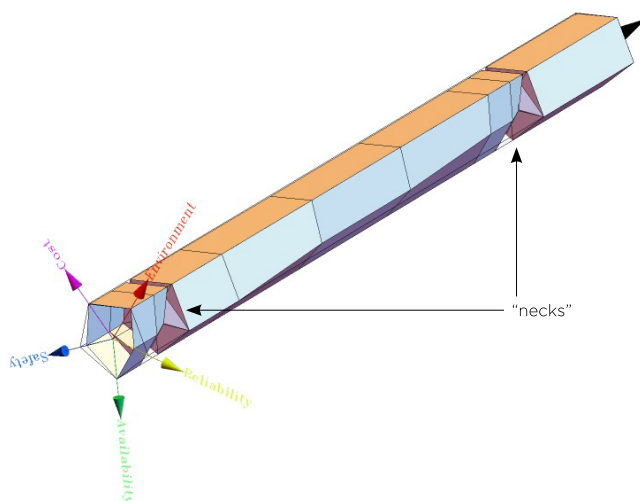

Figure 11. Generation of a Performance Tube over time for the KPIs.

For monetized KPIs, impact of future events is compared with present events as per established Net Present Value (NPV) approach. There is less agreement around non-monetized KPIs. Several studies on social preference of non-monetized properties such as individual emotions and values pose this challenge but the KPIs for bridges have some economic impact. It is therefore decided to deal with the KPIs Reliability, Availability and Safety in the same manner as with the cash flow i.e. to discount them (using NPV) in the same manner as the expenditures for maintenance interventions.

The value of these KPIs is more important today than e.g. in one, two or 10 years. Thus, the interventions on the short term can be more expensive but with more valuable benefits. In order to reduce the KPIs to the same scale as for any time instance, the normalization is performed i.e. the NPV is divided with the NPV calculated if all KPIs were equal to one over the whole investigation period. These values can be regarded as “average” long term KPIs.

The quality control framework is envisioned to have two stages - static and dynamic. The first one typically comprises preparatory work, inspection tasks and snapshot assessment of the KPIs. The second mode implies assessment of remaining service life, KPI development over time and finding an optimal maintenance scenario i.e. decision making.

The steps for a static (snapshot) quality control comprise:

1. Preparatory work

- Study an inventory information
- Identify conceptual weaknesses of the original design
- Identify the material weaknesses
- Compare the current traffic loads to traffic load model used in the original design
- Define the vulnerable zones
- Evaluate à priori reliability

2. Inspection on site

- Identify damages (e.g. cracks, spalling, deformations, etc.)
- Measure on site material properties
- Collect samples

3. Lab test (e.g. carbonatization depth, chloride ingress, etc.)

4. Assessment of the Reliability KPI

- Qualitative assessment of resistance reduction based on observed damages
- Qualitative assessment of reliability (structural safety and serviceability)

5. Assessment of the Safety KPI

The steps for a dynamic quality control comprise:

1. Assessment of a remaining service life

- Assessment of the speed of active damage processes
- Damage forecast
- Reliability and Safety development over time

2. Maintenance scenario

- Reference scenario –intervention at the end of service life
- Preventative scenario
- Estimate long term costs for all scenarios
- Estimate Availability for all scenarios
- Estimate an effect of maintenance on Reliability and Safety

3. Decision making

- Perform multi-attributive or multi-objective optimization
- Monetize non-monetary KPIs
- Determine the optimum scenario

Previous observations (in inspection records, if any) at the same location of the structure can indicate the rate of a damage process and are very valuable for the performance prediction.

In **Figure 12**, both static and dynamic implementation of the methodology for a bridge is presented, details of which are available in WG3 final report.

Typical ways of assessing bridges are as per visual inspection, non-destructive testing, and probing and structural health monitoring. Structural health monitoring (SHM) is generally performed on the bridges of utmost importance for the road network. Equipment acquisition, its maintenance, data collection and analysis require financial assets that are not affordable for large scale use. Therefore, SHM is in most cases used for bridges with large spans only.

Probing provides the most reliable results regarding the state of the bridge and its individual components. Its biggest weakness is the fact that its implementation can cause a certain damage to the construction. In most cases, it is performed when remediation or reconstruction of a specific bridge is already envisaged, however more accurate information on the state of the bridge components is still needed.

The use of SHM and probing is therefore not suitable for large-scale periodical damage detection and assessment. Although somewhat less reliable, for long-term data acquisition regarding the bridge state and its changes over time, two types of data collection techniques remain available: visual inspection and non-destructive testing (NDT).

Both approaches have advantages and disadvantages from the viewpoint of data acquisition, reliability, work pace, required equipment etc. Most importantly, visual inspection disadvantages can be to a large extent eliminated, with the implementation of a suitable inspection protocol and complementary use of NDT.

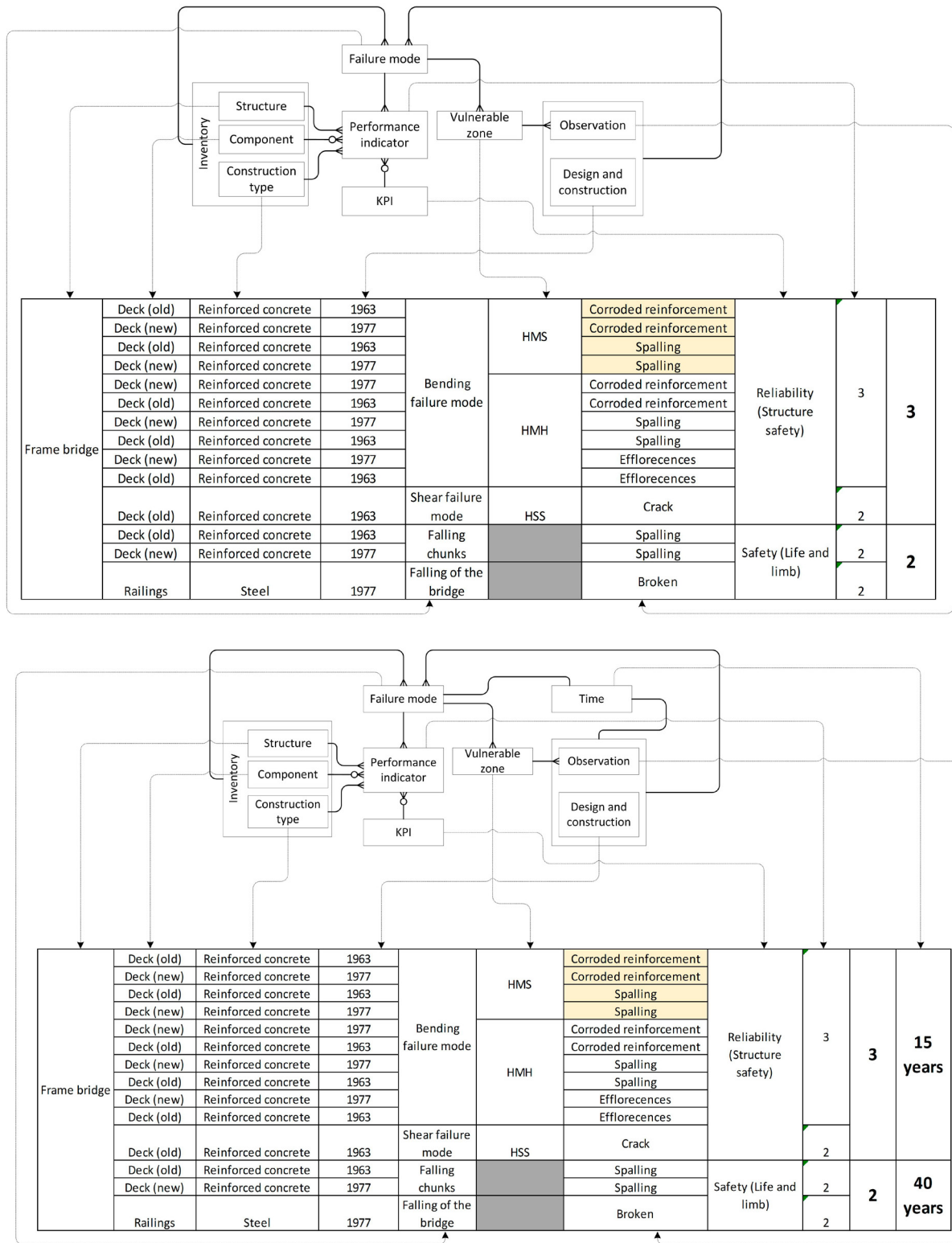

Figure 12. Implemented Static and Dynamic Structural Assessment Framework

The need for appropriately trained inspector and lack of guidelines around the same is noted. The primary inspection task is damage, material properties, defects and other irregularities detection and evaluation. There are three possibilities of their detection: a) correct detection, b) false detection, c) no detection. Also, some performance indicators are more likely to be undetected or falsely detected via visual inspection than others. This can be addressed through the complementary use of Non-Destructive Techniques (NDTs). As their regular use is impracticable due to inspection time and financial resources available per bridge, they should only be employed when detecting performance indicators, which have inadequate reliability when using eyesight alone. The bridge network age and damage state, predominant bridge design and materials used strongly influence the selection of the most suitable NDT to be used. Asset manager and inspectors must first define, which PIs are being addressed during inspections and then analyse them. Some PIs and their assessment may be specific for individual networks.

For majority of PIs visual inspection alone is enough to accurately determine their values, however, in some cases (delamination, concrete cover, concrete strength, etc.) it cannot adequately assess the extent or intensity of damage. The approach in COST TU1406 is to determine PIs that are more difficult to detect and assess (see WG3 final report for details) and should therefore be given more emphasis during the inspection by employing NDTs. The second step of the analysis is to determine the NDTs suitable to be employed into regular bridge inspection practice from descriptive or measurable criteria. The choice of NDT is driven by the reliability of results, test duration, result interpretation and related complexity, cost, usability and standardization.

It should be noted here that standardization does not guarantee high reliability of results: pull off test is standardized (EN 1542) and its results are reliable, however rebound hammer test is also standardized (EN 12504-2), but the reliability of its results is questionable. On-site test duration and time required for the interpretation of the results can also be independent. The duration of the pull-off test duration is relatively long as the adhesive between the disc and the substrate has to harden before the test can be executed, however test results are instant, as no interpretation is needed. Usability and cost criteria are unrelated.

Test duration, defined as the on-site time required for the test execution, excludes time in the office for result interpretation and related complexity. The NDT is defined as quick, if it can be carried out without substantially increasing the duration of the visual inspection of the bridge and moderate if the time is prolonged by up to 50% due to NDT. If time consumption is greater, the usefulness of such NDT as for regular bridge inspection is questionable and should only be implemented when demonstrating exceptional performance in other criteria selected.

Time needed to perform some tests is short, but these tests only provide local results and need to be performed numerous times to provide comprehensive results (e.g. hammer tapping), while others require more time to be performed, but determine the state of construction as a whole for the parameter measured (e.g. infrared thermography). Additionally, for NDTs with wide usability, test duration may vary greatly for different measurements.

Results interpretation in office and related complexity considers NDT undemanding when it is immediate (e.g. phenolphthalein test), satisfactory when short office/on-site analysis is required and demanding when prolonged analysis with highly qualified personal is required (e.g. ground penetrating radar). The cost aspect should equipment acquisition, maintenance, software cost and possible additional equipment needed for testing, with the value of inspectors' time indirectly taken into account in the test duration and result interpretation. The cost of acquisition is highly dependent on the technical characteristics of the equipment.

Overall, a clear analysis and assessment of an NDT should be done to justify its use and one such method using the concept of utility is presented in detail in WG3 Final Report. All NDTs measuring material properties have high utility rating since visual inspection do not cover this important aspect. For damage and defect assessment, NDTs are often less suitable for use during regular bridge inspections due to high complexity of the result interpretation and on-site test duration.

To ensure proper use of equipment, maximum possible accuracy and reliability of results, initial training of inspectors and regular calibration of equipment is required. The training should include:

- Theoretical background of the equipment used as this knowledge improves the interpretation of the data gathered.
- Display of all equipment capabilities to maximize its utilization.
- Use of equipment in practice (it should always be used in the same manner to obtain comparable results).
- Critical evaluation of the data gathered in order to obtain relevant and reliable information.

Quality education of inspectors is one of two key elements when assessing the state of a bridge with NDT. The other is assuring the quality of equipment used. The equipment needs to be regularly calibrated by an accredited organization and in appropriate intervals.

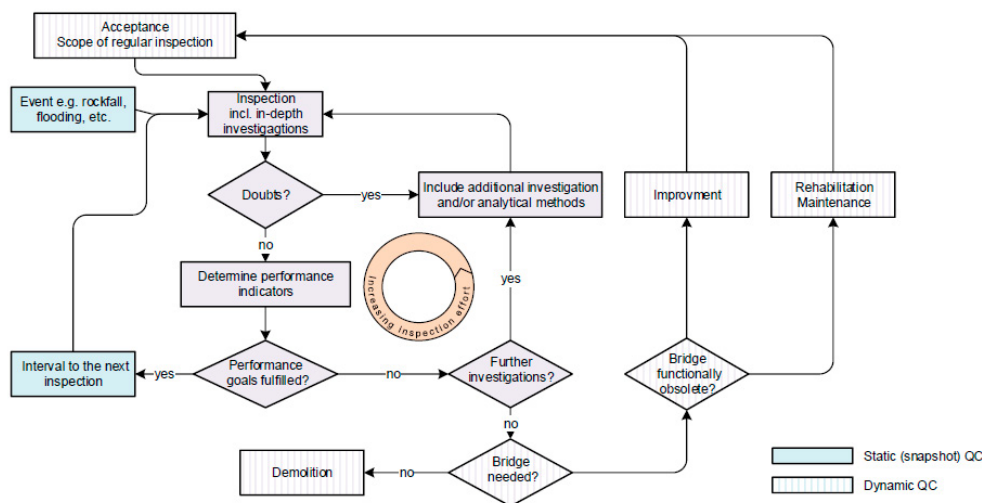

Figure 13. Example of an Inspection Protocol (VSS, 2018)

Inspection Protocol: Diverse inspection methods exist as a direct consequence of diversity of bridge design, age, materials used, damages and deficiencies. For bridges in a good condition, visual inspections are sufficient to determine the values of their KPIs, while for other cases additional investigations are necessary to reliably determine the KPIs.

As a part of QC plan, an inspection protocol is needed to ensure that the inspection data and the decision processes are at or above the desired level of reliability and one such example is presented in **Figure 13**. A high-quality protocol should lead to additional value of information for the inspection (Quirk et al., 2018). Visual inspections need to be performed in predefined intervals and as a function of the distress and needs observed for the structure. For further investigation, the decision is taken jointly by the bridge inspector and the bridge owner as additional financial resources are needed. If they are not undertaken the owner may take other decisions like demolition, rehabilitation, or replacement.

It is not possible to develop an inspection plan that addresses requirements, procedures, practices and trainings to an extent where the data gathered, and the decisions taken will have perfect precision. An element of interpretation in the inspection results will always be present and will therefore allow certain variations in the decision making. This can be greatly reduced using an appropriate protocol, including the one presented in COST TU1406. In terms of other information, ideally a bridge inventory data should be available in the Bridge Management System (BMS) together with relevant parameters/data that are not strictly related to the structural type but are needed for establishment of QC procedures (the list is not definite and has to be adapted based on specific work). The following data is relevant:

1. Data on previous inspections/interventions
2. Bridge age i.e. construction year (insight to historically used codes of practice)
3. Clearance
4. Environmental conditions
 - Location: costal, industrial, urban, rural
 - Microclimate
 - Hazard zone/exposure (flood, earthquake, landslide, etc.)
5. Traffic
 - ADT (Annual Daily Traffic)
 - ADTT (Annual Daily Truck Traffic)
 - Possibility of detour
 - Load posting
6. Inspection and maintenance aspects (incl. costs)

The qualitative scales related to KPIs of Reliability, Safety and Availability are required from inspections. There has been no attempt to align the three scales, e.g. transforming all scales into a monetary or other equivalent unit. The qualitative scales for Reliability also provide statements on urgency of intervention. For some observations, this cannot be evaluated from inspection of the current state (i.e. snapshot in time) but has to be paired with performance prediction models or future observations, as urgency of intervention is dictated by a specific damage process.

The scale for KPI of Reliability

The reliability is related to structural safety and serviceability. Assessment of reliability is not the same as assessment of a condition indicator, since reliability takes into account the virgin reliability (in some countries it is based on the load effects from the codes of practice at the time of construction - often spare capacity may be present in reality. Note: shear capacity was not well understood in older codes of practice), focuses on failure modes and related vulnerable zones.

When estimating the virgin reliability, it is of the outmost importance to account for the previous/superseded codes with limited/no knowledge on the adequate shear design. The known conceptual weaknesses and detailing issues for certain systems (e.g. poor splicing of reinforcement) should be duly considered as well.

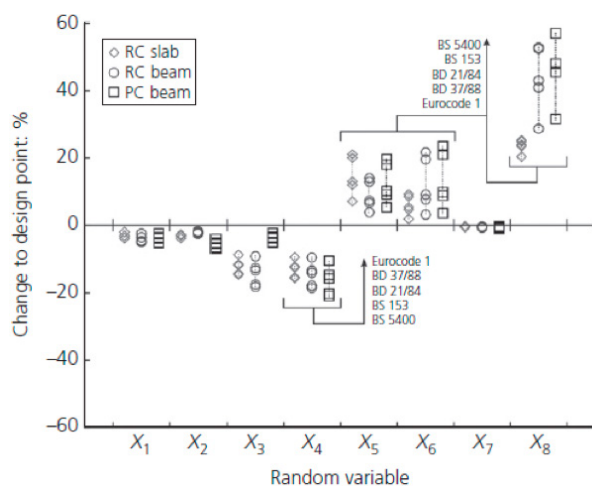

Figure 14. Relative change in random variables at the design point for each code specification for various types of bridges under live loading.

For structures of a similar span, structural type and cross section type, with respect to a similar/same dominant failure mode, reliability curves can be elaborated and linked to quantitative assessments. Reliability estimates can vary over time even based on what codes were used for the same type of bridge over time (**Figure 14**), as observed for live loading (Hanley et al., 2017).

An example of the correlation between the quantitative and qualitative performance indicator scale related to reliability is proposed in Table 2. The above written scales are valid when considering the governing failure mode (i.e. the most critical) and concern only structural safety. For serviceability (e.g. reduction/loss of functionality), similar definitions may be elaborated.

Reliability scale	Quantitative scale (β)	Urgency of intervention
Structural Safety		
1	> 4.00	Regular inspection
2	3.25-4.00	Reassessment should be performed to update the period between inspections
3	2.50-3.25	Reassessment should be performed to plan an optimal time of an intervention
4	2.00-2.50	Reassessment and possible intervention shall be performed shortly after an inspection
5	< 2.00	Immediate action/intervention is required
Serviceability		
1	> 2.50	Regular inspection
2	2.00-2.50	Reassessment should be performed to update the period between inspections
3	1.50-2.00	Reassessment should be performed to plan an optimal time of an intervention
4	1.00-1.50	Reassessment and possible intervention shall be performed shortly after an inspection
5	< 1.00	Immediate action/intervention is required

Table 2. Scale for KPI Reliability and urgency of intervention for structural safety and serviceability.

The scale for KPI of Safety

An example of a qualitative scale, related to Safety, and related correlation between qualitative and quantitative values is proposed in Table 3.

Safety scale	Quantitative scale	Qualitative scale
1	Injury return period > 100 years	No danger. It is very unlikely that a person could get injured because of the current bridge performance.
2	Injury return period ~ 75 years	It is very unlikely that a person could get injured because of current bridge performance.
3	Injury return period ~ 50 years	It is unlikely that a person could get injured because of current bridge performance. Intervention shall be performed before next inspection
4	Injury return period ~ 20 years	It is likely that a person could get injured because of current bridge performance. Intervention shall be performed shortly after inspection.
5	Injury return period < 10 years	Immediate danger. It is very likely that a person could get injured because of current bridge performance. Immediate action is required.

Table 3. Scale for KPI Safety

The scale for KPI of Availability is given in Table 4.

Availability scale	Qualitative scale
1	No restrictions to traffic
2	Weight, speed and lane restrictions for heavy trucks
3	Closure except for cars and regular lorries. Possible lane restrictions for regular lorries.
4	Closure except for cars. Possible lane restrictions for cars.
5	Complete closure

Table 4. The scale for KPI Availability

3.5. INTERACTION WITH INDUSTRY ADVISORY BOARD

To establish the suitability of the final reports and proposed methodologies along TU1406 for industrial application, an Industry Advisory Board (IAB) was formed. The industry Advisory Board has been asked by the COST TU1406 core group / chair to review the outcome and deliverables from the cost actions and comment based on the applicability in practice for the industry.

The IAB uses web-meetings and subsequent individual contributions to arrive at comments and suggested improvements of the reports of relevant WGs. This is especially true where the exploitation of the outcome is relevant for several groups of stakeholders. The IAB has been able to create an impact in various reports, especially commenting on the need for harmonisation of terms and definitions, data screening and access, consolidation of results, feasibility of scope, industry verification, standardization requirements and possibilities, scalability and ease of implementation in an industrial format. The impact and inputs of IAB will continue till the end of the Action.

3.6. INTERACTION WITH NORMATIVE BODIES

3.6.1. OVERVIEW

Guidelines and recommendations as provided in the different WG reports are useful. However, standards are required by bridge owners to have an agreed basis for asset and maintenance management of bridges. The COST Action TU 1406 has produced relevant documents and results that can contribute to the activities international standards and finalize with the adoption of standards for QC of highway bridges. The liaison handled by comprises CEN TC 350 and CEN TC250 (especially WG2). In addition, fib (the International Federation for Structural Concrete) and JCSS (Joint Committee of Structural Safety) is considered for liaison. Apart from these bodies, the members have been encouraged to interact with relevant normative bodies within their own countries (e.g. National Standards Authority of Ireland).

It is observed that the process of standardization itself is a slow process and a small sub-set of results and recommendations can eventually get through to the standards, if possible. Under such circumstances, the recommendations, guidelines and examples are recommended to create a pathway towards standardization process as the core objective of COST TU1406. While standardising the parameters (WG1 results) for bridge assessment cannot be achieved in this framework and would require a specific standard for bridges only, the systematic approach of our assessment procedure and useful definitions for the non-technical parameters (economy-environment-society) can be extremely relevant in this regard.

Presence in both CEN TC250 and CEN TC350 form COST TU1406 has indicated the mutual interest for this liaison, during and especially beyond the completion of the Action. For JCSS, activities relevant from COST TU1406 are, a) assessment framework and Bayesian Nets (WG3); b) Risk-based quantification/ monetization of KPIs (WG2//WG3) and c) Decision-making procedures addressing KPIs (WG2) – all leading to better maintained structures.

A workshop is being hosted in Iceland in April, 2019 with contributions from all these normative bodies for dissemination and for interaction to forge a pathway for conduiting the recommendations and guidelines to relevant standardization process beyond the lifetime of COST TU1406. A roundtable discussion and summary of the same will be contributing to the knowledge of TU1406 as well as for the road bridge maintenance and management community.

3.6.2. DISCUSSION AROUND SUSTAINABILITY AND INDICATORS

ISO 21929-2 describes and provides guidelines for the development of sustainability indicators related to civil engineering works and defines the aspects and impacts of civil engineering works to consider when developing systems of sustainability indicators. They form a basis for the suite of ISO/TC 59/SC 17 standards intended to address specific issues and aspects of sustainability relevant to construction works.

The issue of sustainable development is broad and of global concern, and, as such, involves all communities and interested parties. Both current and future needs define the extent to which economic, environmental and social aspects are considered in a sustainable development process. While the challenge of sustainable development is global, the strategies for addressing sustainability in civil engineering works are essentially local and differ in context and content from region to region.

These strategies reflect the context, the preconditions and the priorities and needs, not only in the built environment, but also in the social environment. This social environment includes social equity, cultural issues, traditions, heritage issues, human health and comfort, social infrastructure and safe and healthy environments. It can, in addition, particularly in developing countries, include poverty reduction, job creation, access to safe, affordable and healthy shelter, and loss of livelihoods.

ISO 21929 also defines a framework for the development of sustainability indicators for civil engineering works based on the premise that civil engineering works contribute to improving the economic, social and environmental aspects at local, regional and global levels with minimum adverse impact. This follows the general principles presented in ISO 15392.

In this context, indicators are considered figures or other qualitative or descriptive measures that enable information on a complex phenomenon, such as, environmental impact, to be simplified into a form that is relatively easy to use and understand. Four main functions of indicators are quantification, simplification, communication and decision making. Changes in a civil engineering works over time and the development of changes in relation to stated objectives and targets should be monitored with the help of indicators.

When developing and selecting indicators, the starting point is the identification of the main users and user needs.

Sustainability indicators for civil engineering works are needed in decision-making by several interested parties, such as: Public bodies and policy makers; Investors, owners and promoters; Planners, developers and designers; Governmental and non-governmental organizations (considering interest groups both at national and at local level); Manufacturers of products; Contractors; Operators and maintainers; Users and other stakeholders who are given service by the infrastructure and Local residents. Sustainability indicators, as well as sets and systems of indicators, for the specification, assessment, and representation of the contribution of a civil engineering works to sustainable development can be used in many ways.

For example, among others, their application can support the following: design and decision-making process(es) during the planning, and design stage of a civil engineering works (e.g., incorporation in the design of sustainable material, technologies, processes and other components); development and application of assessment methods and certification systems; specification and verification of environmental and social requirements in the context of procurement; indicating the civil engineering performance (e.g. marketing); measuring, monitoring or evaluating the performance and achievement of sustainability objectives over the different life cycle stages of the civil engineering works; identifying critical trends, both positive and negative, in the development and operation of civil engineering works; accepting responsibility for impacts on the environment and the society; representation of activities and results in the context of responsibility towards the economy, environment and society (e.g., sustainable development reporting).

When assessing or setting targets for the contribution of a civil engineering works to sustainability, the use of other sustainability indicators may be relevant depending on the specific circumstances of the civil engineering typology and location. Indicators can address economic, environmental and social impacts directly as well as issues that have indirect consequences on such impacts. In some cases, the indicators will address more than just a single aspect of sustainability.

The three dimensions of sustainability (environmental, economic and social) and impacts should be taken as the basis for the development of indicators for assessing the sustainability performance. When developed, the sustainability indicators should be: essential from the view point of assessing the contribution to sustainability and sustainable development; relevant for both new and existing works. An eventual contribution of WG1 to this objective is thus recommended.

3.6.3. DISCUSSION AROUND STANDARDIZATION

There are several standards around this subject which are already widely used and could provide a suitable framework for COST TU1406. In ISO 55000, the principles of Asset Management are standardised. The procedure, into which TU1406 results can eventually fit in, is described and organised.

ISO 55000 describes the subject as a cyclic management approach where monitoring is the main driver for the identification of changes. The information retrieved from the monitoring data is taken in the entire process to improve performance. The scope around this topic is given in **Figure 16**.

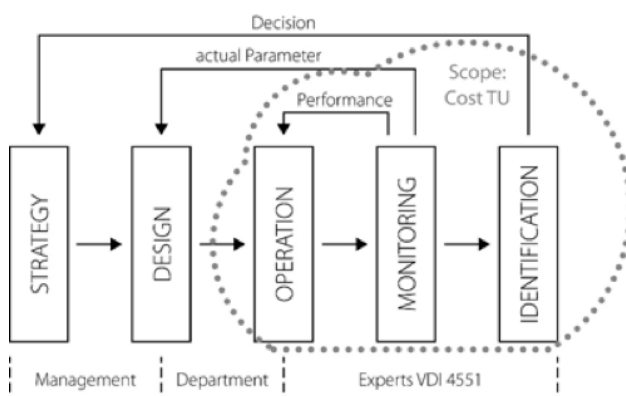

Figure 16. Scope of COST TU1406 around Standardization.

ISO 31000 is devoted to a risk management framework. This is an integrated part of Asset Management. This generic standard has very good representations of the basic principles and provides useful definitions. Several sub-standards like ISO 31010 go into much more detail (**Figure 17**). In order to receive a result that can be used in practice, it will be necessary to form out of the generic principles a specific approach for bridges.

Well-established results from previous projects (IRIS, SafeLife-X etc.) and COST TU1406 results can integrate into this procedure. A verbal harmonisation of various international standards for bridge inspection by the IRIS project is available in this regard. The need of calibrating and comparing inspections with the closest estimated levels of safety through reliability indices remain. A calibration in this regard for different countries and normative documents are presented in **Figure 17**.

The mathematical formulation of degradation of bridges implemented by the CWA 16623, which has found already entrance to various national codes and will be an annex to the new Eurocode on risk-based Inspection. Alternative visualisations of such reliability and inspection relationships, related to available information is thus possible and examples are presented in **Figure 18** and **Figure 19** around safety level assessment and a colour scheme for risk results, respectively.

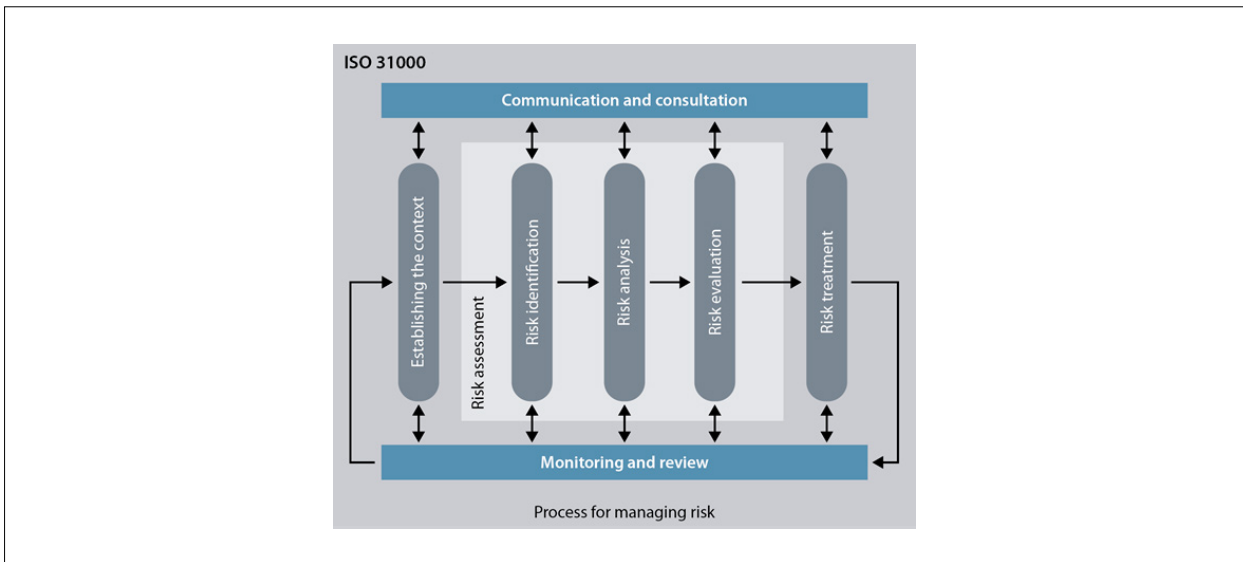

Figure 17. The ISO 31000 Process for Risk Management

The Spider Diagram in particular (Figure 20), developed in COST TU1406 provides an excellent visualisation for multiple aspects around such assessment and consequent maintenance management activities, especially for multiple aspects considered. The independent axes can be selected from the overall guidance from WG1-3 and the final representation as a Spider Diagram makes the road bridge management system more holistic, while allowing for various networks to implement it close to the way it is being currently done now.

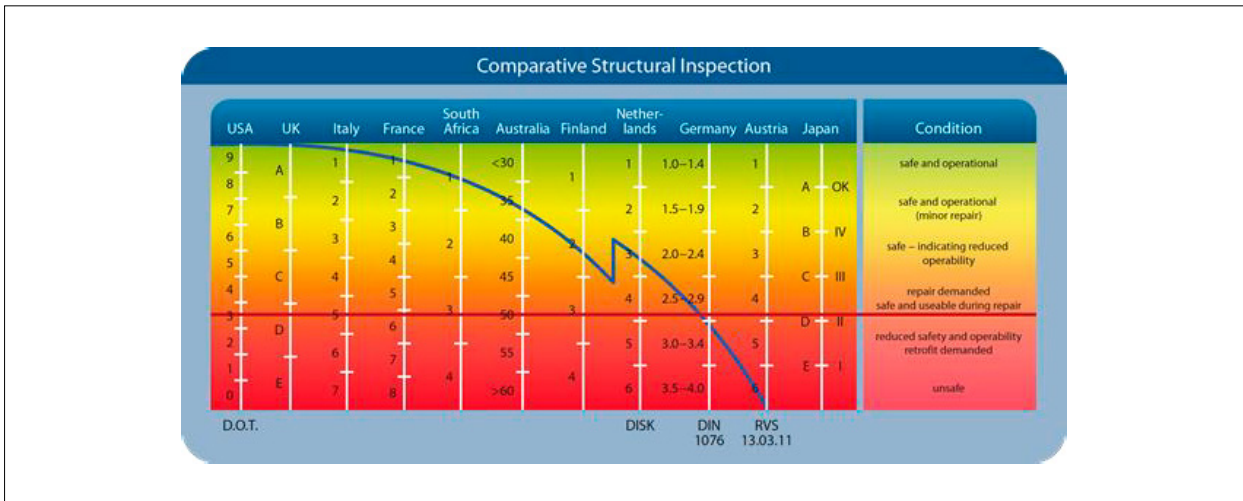

Figure 18. Comparison of structural inspection for performance over time.

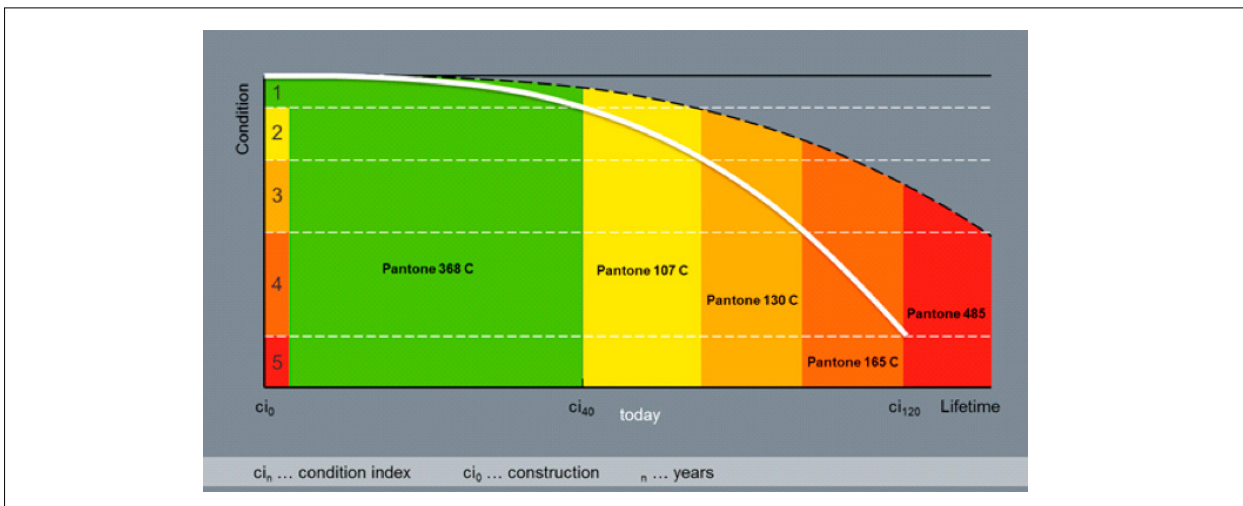

Figure 19. Evolution of safety level of a structure over time.

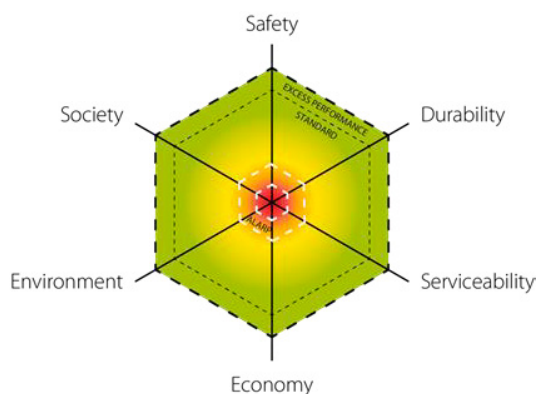

Figure 20. Evolution of safety level of a structure over time.

These observations and developments lead to the need of discussion and agreement on the principle approach create a pathway for standardization. Harmonisation of the available work into a conclusive procedure, alignment with specific working groups in normative organisations and tools for such discussions (e.g. Iceland Workshop of COST TU1406) are relevant for promoting the results to the international standardization bodies.

The complicated democratic process of finding agreement among all parties involved must be kept in mind here for any standardisation process and the expectations should thus be realistic.

The overall picture of asset management should always be kept in mind in this regard. While this can be organised in various ways, Figure 21 presents an approach relating the approach of various normative documents relevant for EU.

In a paper recently presented to COST TU1406 (ref), CEN TC350 provides an overview of the possible overlap and opportunities for TU1406 results to align with TC350. The focus seems to be around the core issue of sustainability. This paper is presented in Appendix of this report.

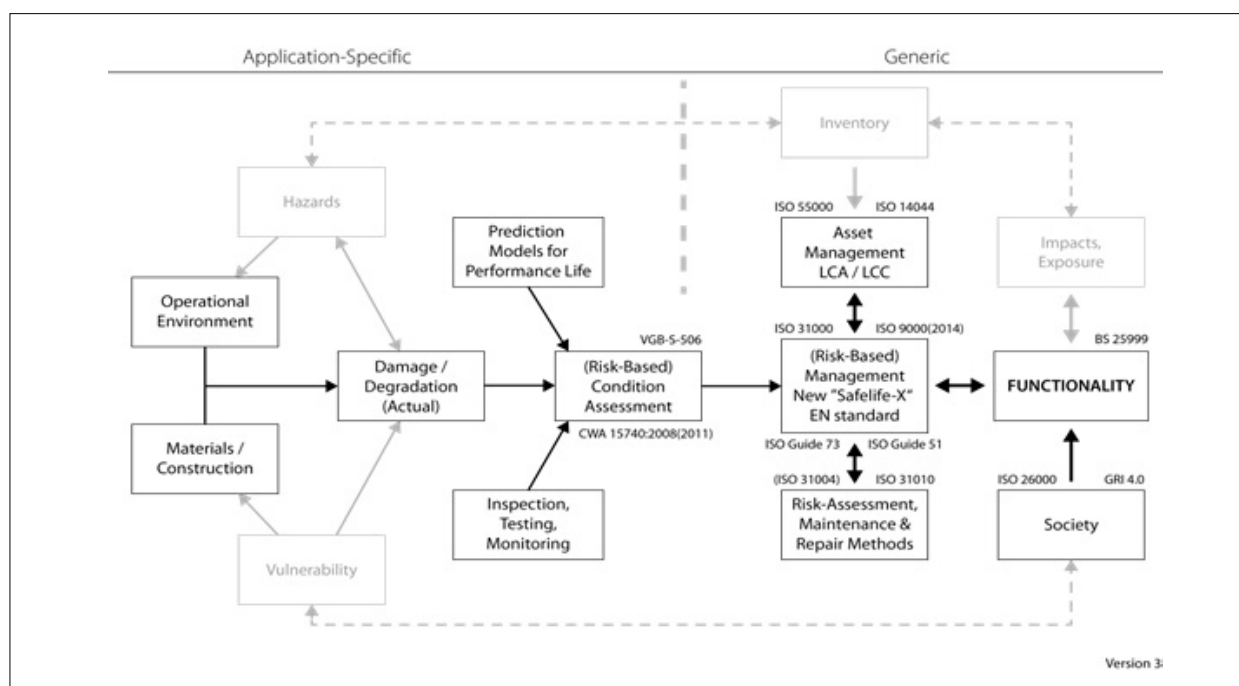

Figure 21. An overall asset management framework.

3.6.4. CONTEXT AROUND EXISTING ACTIVITIES OF SOME STANDARDIZATION BODIES

Standards are required by bridge owners to have an agreed basis for asset and maintenance management of bridges. In terms of liaison, in a recent CEN TC250 meeting in Norway, COST TU1406 had a formal presence and established a liaison to carve definitive paths for future contribution.

The scope of contribution, while limited to assessment of existing structures, was observed to be of mutual interest. There has been contacts with CEN TC 350, WG6, Secretariat: AENOR; Standard: “Sustainability of construction works – Civil engineering works sustainability assessment methodology” and ISO/TC 59/SC 17, WG5, Secretariat: AFNOR; Standard: ISO 21931-2 “Sustainability in Buildings and civil engineering works – Framework for methods of assessment of the sustainability performance of construction works – Part 2: civil engineering works”.

Both approaches are complementary and are led by the same. In ISO, the work is even more generic than CEN but in line with other typical ISO standards and shows good progress. So far one meeting have been held with COST participation and pathways for collaboration can be beneficial.

3.7. INTERACTION WITH ROAD BRIDGE ASSET STAKEHOLDERS

WG5 has considered COST TU1406 as an important platform for interacting with owners and managers of road bridge networks. This has led to strategic interactions gathering experience and commentary from the owners on managers on how their bridge stock is maintained. This exercise not only allowed WG5 to get an idea on how the maintenance programme is implemented in various countries, but also gave an idea of the broad spectrum of challenges and the commonalities that exist for implementation. This in turn established the format and the level at which the recommendations and guidelines are summarized.

WG5 used two main instruments to engage with the owners and managers. The first approach was via several meetings over the lifetime of the action where presentations and face-to-face interactions enriched the information obtained from other WGs. The second approach was by developing a questionnaire, which subsequently led to the development of specific fact-sheets (see Appendix for details) providing insights to the management of such networks.

3.8. COMMENTARY ON DISSEMINATION

WG5, unlike other WGs do not produce information but rather try to synthesize and augment the existing information obtained in this Action. Under such circumstances, the dissemination from this group has been specific. A Training School in Dublin, Ireland has been carried out around the topic of WG5 over two days. Additionally, several papers have been published in a number of conferences around this topic. WG5 has recently contributed to a journal paper on the Value of Information for visual inspection of bridges as well. Currently, a special issue in ICE Infrastructure Asset Management is under way looking into quality specification and standardization of bridge infrastructure (<https://tinyurl.com/yxew984u>).

It was observed during this action that a platform for the type of activities carried out by COSTS TU1406 is not available at a pan-EU level. To address this, a new EU body, EuroStruct (www.eurostruct.org) was established, which will continue to work towards this standardization and industrial liaison process with the researchers after the completion of COST TU1406. EuroStruct is an association which aims to promote the understanding and advancement of practice on quality control of bridges and structures at a European level. This is achieved by

- a.* improving the quality of bridges and structures in Europe;
- b.* promoting worldwide cooperation and understanding through the exchange of knowledge and experience in quality control;
- c.* encouraging awareness and responsibility of structural engineers towards the needs of society;
- d.* encouraging actions necessary for progress of quality control in bridges and structures;
- e.* improving and fostering cooperation and understanding between organisations with similar objectives.

In order to fulfil its mission and objectives, the Association will organise meetings, seminars, conferences and related activities independently or in collaboration with other organisations. The Association intends to collaborate with other organizations and institutions with objectives consistent with its own. The Association also intends to publish reports, communications, periodicals, books, amongst others, identify research and development needs, and initiate and support research activities.

3.9. MAIN GUIDELINES AND RECOMMENDATIONS

Based on the results and recommendations of the reports from WG1 to WG4 and the comments provided by the IAB, normative bodies and stakeholders, COST Action TU1406 has stated the following guidelines in the adoption of a common QC framework for highway bridges in the European countries.

- 1.** Guideline on the definition of performance indicators for QC and collection of a European data base of observations and performance indicators
- 2.** Guideline for the adoption of a common QC framework based on the adoption of 4 KPI (Key Performance Indicators: Reliability, Safety, Availability and Cost) and the 3-D spider tool for the practical implementation in a specific bridge in order to obtain the optimum maintenance scenario.
- 3.** Guideline for practical implementation of the QC plans and definition of the 3-D spider tool for a specific bridge.

These last two Guidelines are fully described in the reports of WG3 and WG4 and summarized in the present chapter and will be highlighted using 3 different case studies as presented in next chapter 4.

4. EXAMPLES OF QC FRAMEWORK AND IMPLEMENTATION OF THE SPIDER TOOL

To illustrate the developed Spider Tool and the development of the Diagram, 3 examples of implementation are selected from work in WG4 spanning a range of bridges, countries and the complexity and detail involved in such implementation. The complete set of implementations is available with the detailed report of WG4. These implementation examples illustrate how the approach considered in COST TU1406 can be applicable for a range of scenarios without upsetting the existing method of inspection, assessment and maintenance of the bridge while adapting to the recommendations and guidelines of this Action. This is where the demonstrative evidence around homogenisation and standardization lies.

4.1. IMPLEMENTED CASE STUDY 1: GIRDER BRIDGE IN DOBŘÍŠ, CZECH REPUBLIC

This Case Study considers a Girder Bridge with asphalt pavement and steel crash barriers in Dobříš, Czech Republic, built in 1983 (**Figure 22**). The bridge carries the highway D4 across the local road III/10226 close to Dobříš town (average daily traffic: 20306, cars; 3868 heavy vehicles). Foundations are inaccessible with no precise drawings, the abutments are made of concrete, while two superstructure sections (one for each traffic direction) comprise of 10 precast and prestressed I73 concrete girders with each girder supported on steel bearings - one fixed and one movable. The drainage is on the sides. Based on a Finite Element numerical analysis available, the estimated load capacities are as follows: i) Normal capacity of unlimited number of vehicles: 24t; ii) capacity of the one single vehicle on the bridge:53t; iii) Exceptional capacity for heavy special transport: 292t. The critical member is a side beam and its bending capacity. According to the Czech rating system, the status is V (bad) for the superstructure and IV (satisfactory) for the substructure, on the scale between I (excellent) and VII (emergency), The availability is of the grade 2 (available with limitations) on the scale between 1 (available) and 5 (Unavailable).

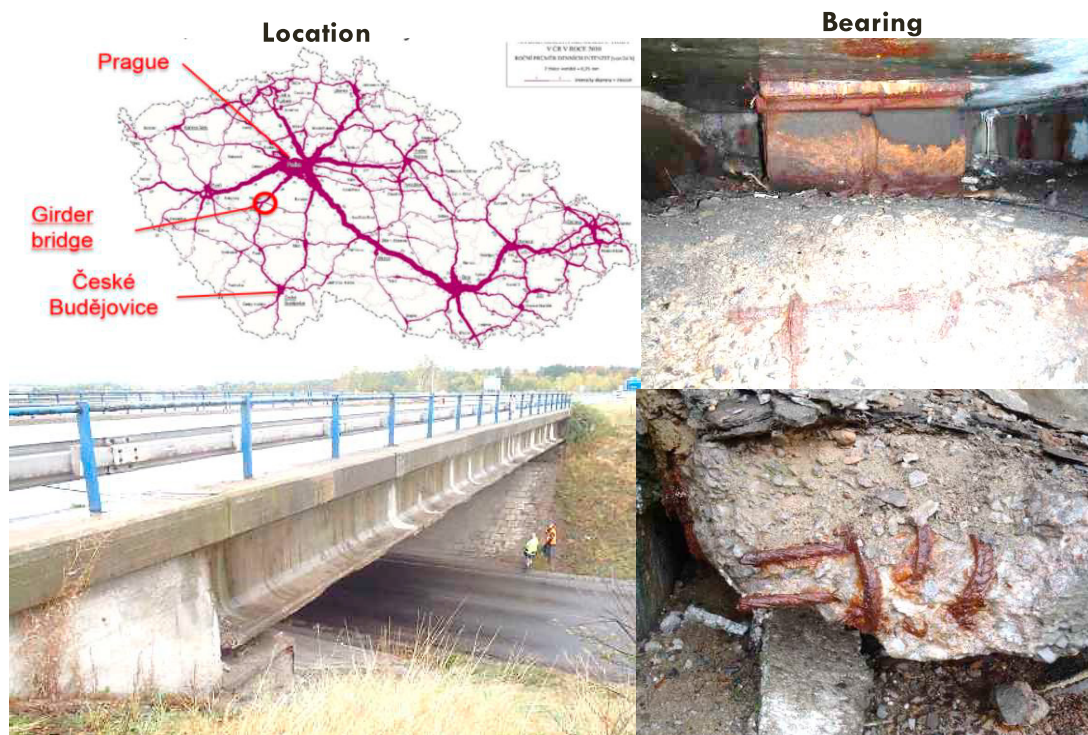

Figure 22. General information about the case study girder bridge

An inspection indicates: a) Concrete deterioration and the reinforcement corrosion of both abutments; b) Concrete deterioration and the reinforcement corrosion of main girders; c) Defects of expansion joints; d) Waterproofing defects; e) Deterioration of the concrete parapets (ASR) and f) Bearings damage.

Potential failure regions identified are: a) Failure of the edge girder, because of the concrete degradation and reinforcement corrosion, which influences the prestressing cables and/or prestressing anchors, leading to the girder failure. Note: This is the most probable scenario, as the leakage to the anchoring area can lead to the corrosion of the prestressing reinforcement close to the anchor; b) Failure of the bearings, because of the heavy corrosion – but this will take a long time, and the consequences are not critical; c) Loss of stability of the abutment under the edge bearing, the local pressure into the deteriorated concrete will lead to the local girder failure (slip of the girder, the failure will result in the large deformation, not to the global collapse).

There is evidence of alkali-silica reaction and the range of compressive strength of concrete is available from various girders from materials testing. The depth of carbonation is 8,6 mm on the main girders (5-11mm), 26,7 mm on the abutment (11-46mm) and 36,7mm (37-45mm) on parapet. The superstructure can resist 75 freeze-thaw cycles, but the abutment concrete is damaged after 25 cycles.

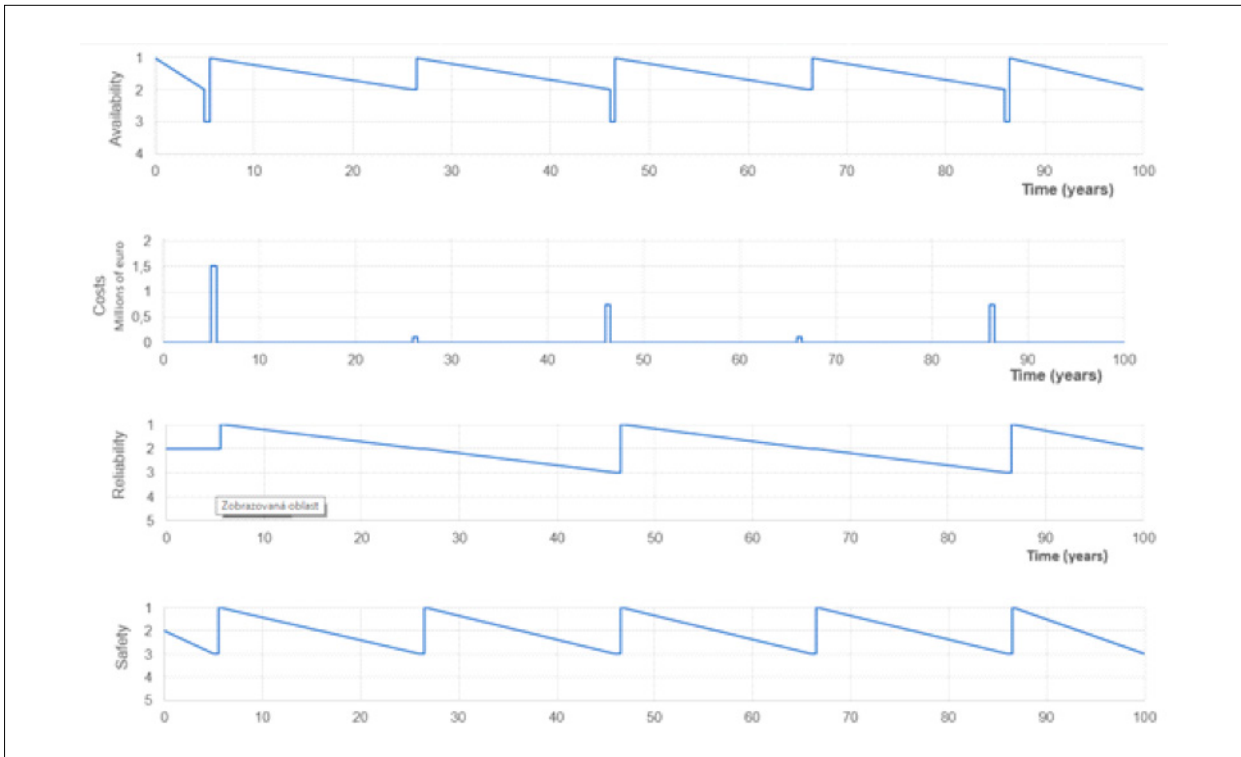

Figure 23. Evolution of key parameters under preventative maintenance scenario.

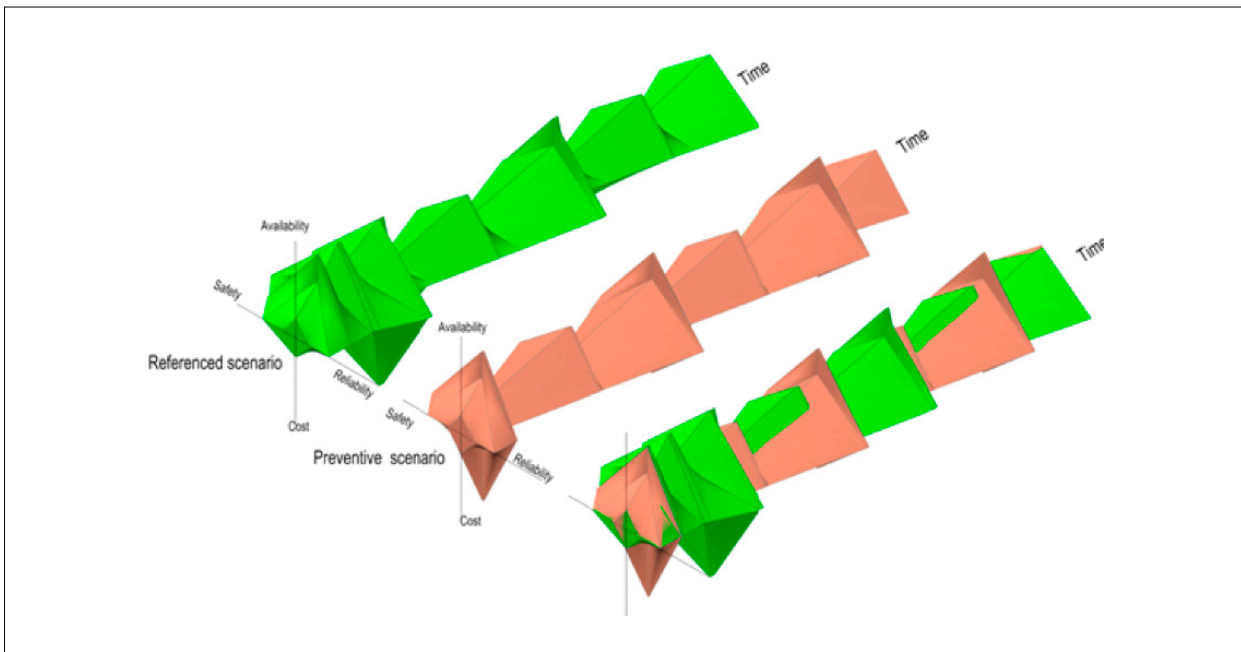

Figure 24. The comparison of the safety, reliability, availability and cost in time and volume comparison.

KPIs are established as per best practice knowledge in Czech Republic. The estimated failure time is assumed according to experience with concrete structures in Czech Republic and estimated progress of the defects, but on the safe side under severe exposure conditions. Considering relevant material, loading and model uncertainties, the estimated reliability index (B) for dead load is 4.1 and for live load it is 3.5. This lower value is chosen conservatively to represent the condition of the entire bridge in relation to the risks identified. By reducing epistemic uncertainty through such approach a small increase in load capacity can be established.

Scenario 1 considers:

- a.** pavement failure in five years due to crack development at the expansion joint, sweating and deformation in five years (as noted the pavement layer shall be repaired);
- b.** pavement repair waterproofing with temporary decrease of availability;
- c.** concrete parapet collapse in 10 years leading to installation of temporary concrete crash barrier can change with decrease of availability & safety, due to narrowing of bridge;

- d. loss of the stability of the abutment under the bearing, or the likely failure of the prestressing cables in 20 years leading to bridge failure and replacement with new structure with bridge closure and lack of availability.

The evolution of key parameters of assessment over time is presented in **Figure 23**.

The Scenario 2, considering preventative approach has the following assumptions:

- a. bridge repair done in 5 years;
- b. pavement failure in five years due to crack development, sweating and deformation in five years and subsequent repair;
- c. Laying of a new concrete deck on top of prestressed girders and replacement of side beam leading to drop of the availability from bridge closure.

The adjacent bridge will carry one traffic lane in each driving direction, with slower traffic and traffic jams; d) pavement replacement every 20 years and bridge repair every 40 years with temporarily decreased availability.

A comparison of the two considered approaches is carried out by implementing the ‘Spider Diagram’ proposed in COST TU1406.

The preventative approach is more appropriate for the arch bridge as the indicators show more favourable results for safety, reliability and availability. Only the costs are almost comparable, due to the normalization of the costs based on 2% interest rate. Over 100 years, the Spider diagram can be extended to 3D, as observed in **Figure 24**.

The comparison gives the first, referenced scenario as: 180 versus the preventive scenario as: 146. Thus, This the preventive scenario is generally closer to the best “1” grade and is more appropriate over the entire life.

4.2. IMPLEMENTED CASE STUDY 2: ARCH BRIDGE, GUARDA DISTRICT, PORTUGAL

This Case Study considers an arch bridge in Guarda district Portugal with one span open spandrel deck arch with total length of 24.00m and rise of 4.65m (**Figure 25**). Structural elements of this bridge are: deck slab (A), arch slab (B), arch abutment/springing (C), spandrel piers(walls) above the arch (D) and piers (walls) at the springing (E).

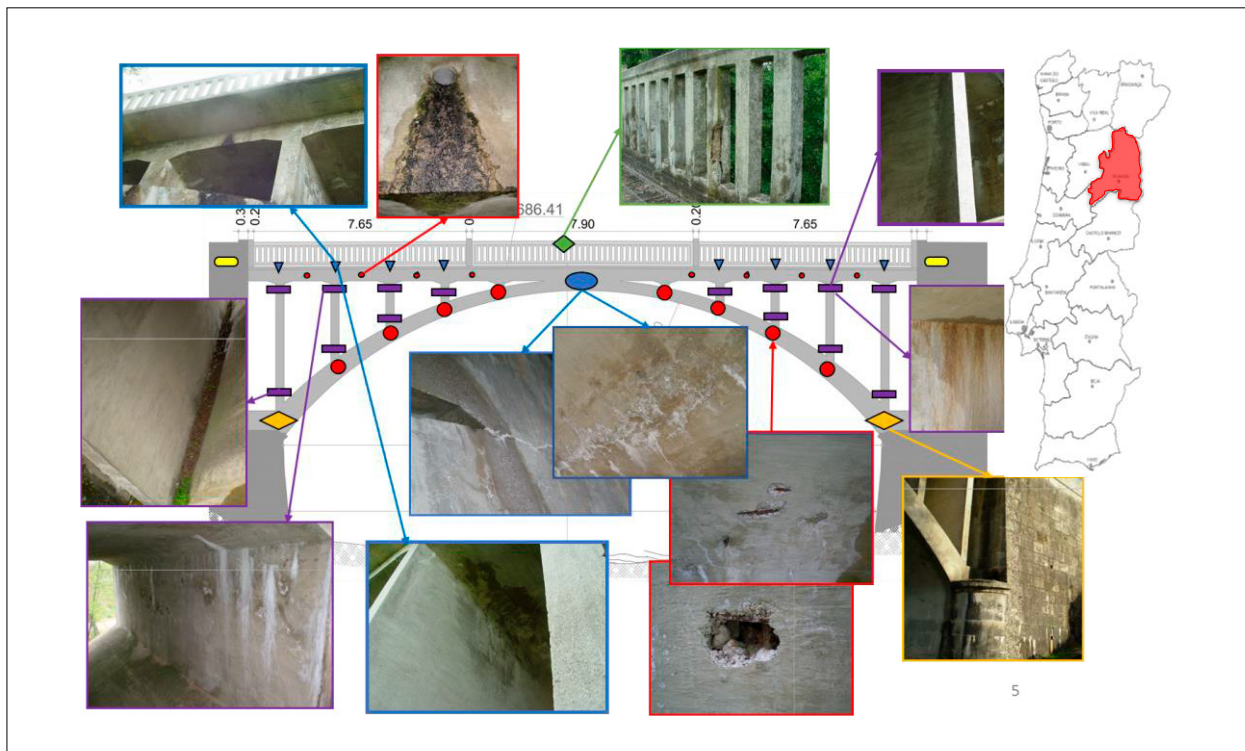

Figure 25. General information about the case study arch bridge identifying vulnerable regions.

The bridge carries the regional road 324(ER) over the river Cro. The road cross-section consists of: two traffic lanes 2.53m and 2.51m, two safety strips 0.45m and 0.51m and two sidewalks of 1.0m width. The bridge is constructed in 1940 and repaired in 2010. As per 2016, the average annual daily traffic is 1766 with 5% heavy traffic. The vulnerable zones are identified from inspection. A Finite Element analysis indicates the bending moments at the supports are very low comparing with the bending moment at the midspan, showing that the system is simply supported. Therefore, the overall reliability of the bridge was obtained as the reliability of the midspan section of the arch.

Several scenarios of maintenance were considered. A bi-linear deterioration model was used to approximately estimate the reliability index over time, $\beta(t)$, decreasing uniformly at a rate of 0.07 per year. Since this model is applied on the existing structure, the deterioration processes are assumed to be already initiated in the past and the deterioration initiation time is assumed to be zero.

From the same reasons, β_0 in this model refers to the reliability index at the time of the last inspection, i.e. to the reduced initial index due to the qualitatively assessed resistance reduction.

In this scenario (Scenario 1, **Figure 26**) no maintenance was considered until reliability reached an index of 2 which is the upper bound of the state 5. In that point of time, replacement of the whole structure was considered leading to a highest improvement of the reliability ($\gamma = \beta_0 - \beta_{state\ 5} = 4.26 - 2.00 = 2.26$) immediately after the replacement. The reliability index in this point is equal to the initial "virgin" reliability β_0 since the deteriorated structure is replaced with a new one. Restoring of the reliability index to an initial value also leads to a delay in the degradation process ($t_i = 7$ years). The same action of replacing the whole bridge was taken each time the reliability index reached the state 5 without any maintenance in between (degradation rate 0.07/year).

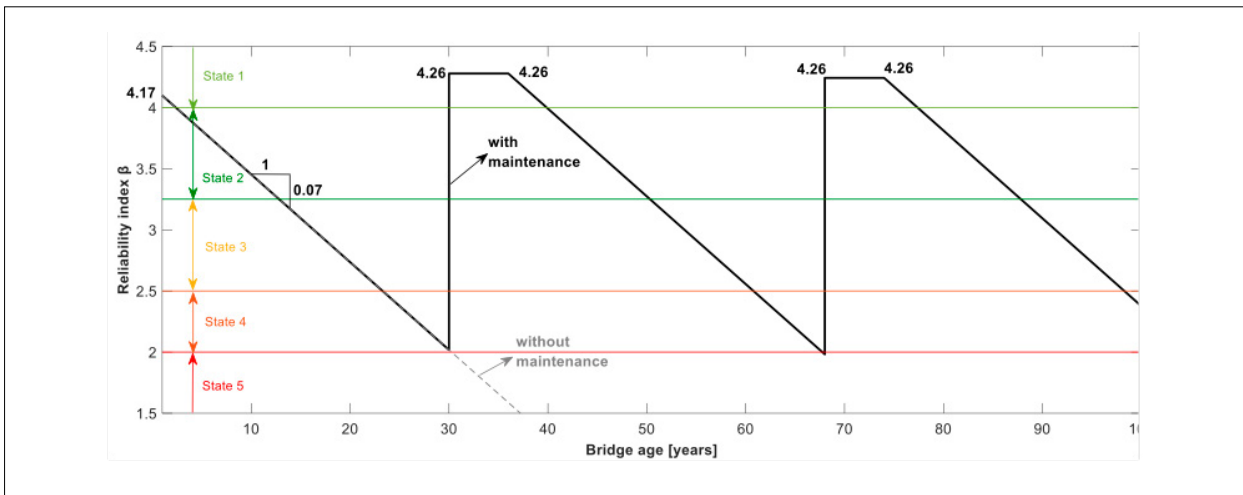

Figure 26. Semi-quantitative performance indicator reliability under Scenario 1

Reliability is qualitatively transformed using the correlation between the quantitative and qualitative performance indicator scale proposed by WG3 of the Cost Action TU1406. For this scenario, availability, costs and safety were evaluated only qualitatively (**Figure 27**). Availability is decreasing rapidly during the transition of the reliability from a level 4 to a level 5. It has highest value during the replacement of the bridge. Since no maintenance in this scenario was considered, costs were included only due to the bridge replacement. Decrease of the user safety was considered to be faster than the decrease in the structural reliability. A first order second moment approach helped estimate an initial reliability index, which was subsequently reduced slightly on the basis of the last visual inspection by considering a 5% resistance reduction.

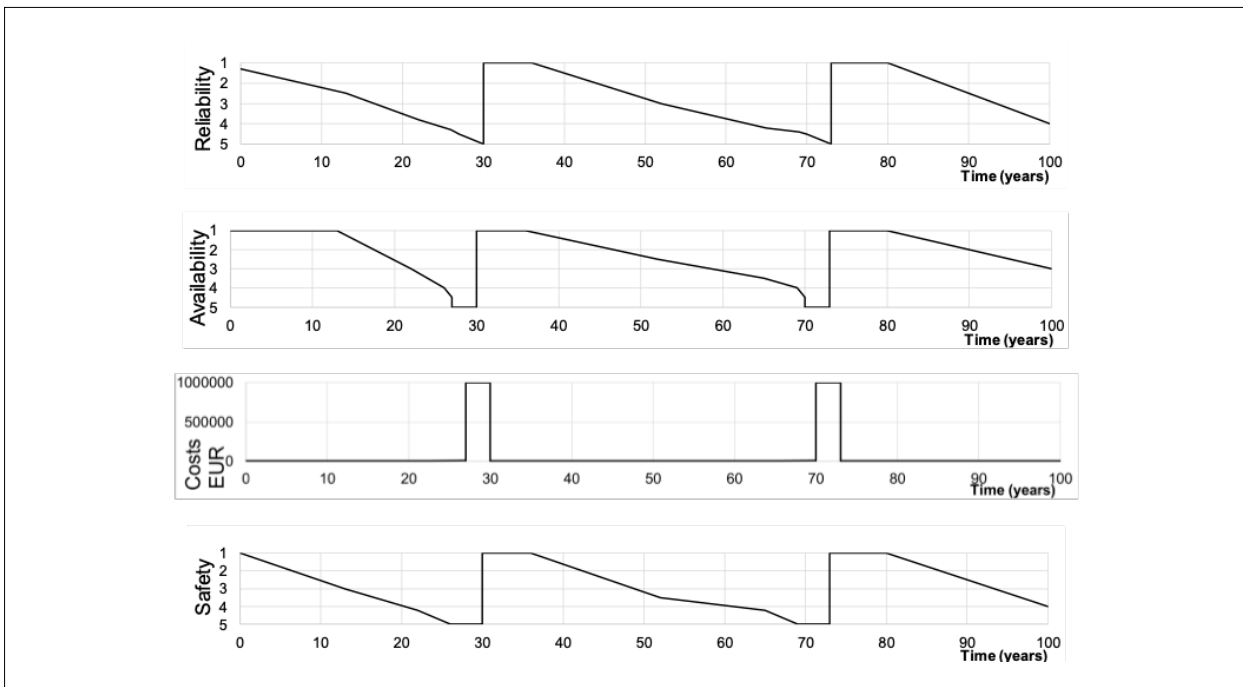

Figure 27. Evolution of key performance indicators under Scenario 1

A second degradation scenario (Scenario 2, **Figure 28**) is considered where the effects of corrective maintenance actions were modeled through an improvement in reliability immediately after the application of a maintenance γ and a reduction of the deterioration rate for a period of time after its application.

Using observed defects, a first corrective (essential) maintenance action was taken while the bridge is still in overall good condition (state 3). Identical corrective actions were assumed to be taken periodically over 13 years with lower improvement in reliability ($\gamma=0.53$).

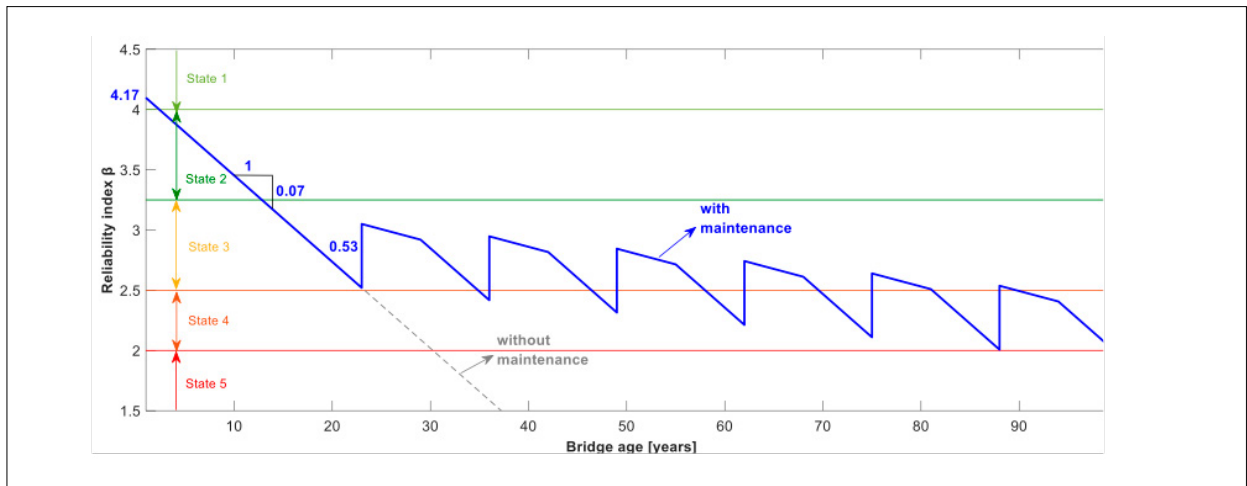

Figure 28. Semi-quantitative performance indicator reliability for Scenario 2

For this scenario, availability, costs and safety were evaluated qualitatively (**Figure 29**). A decrease in availability was considered over time. During the corrective action, the availability is reduced, while immediately after the action, a small improvement was assumed. Moderate costs were considered for the corrective actions. User safety was considered to decrease over time, with a small improvement immediately after the performed action.

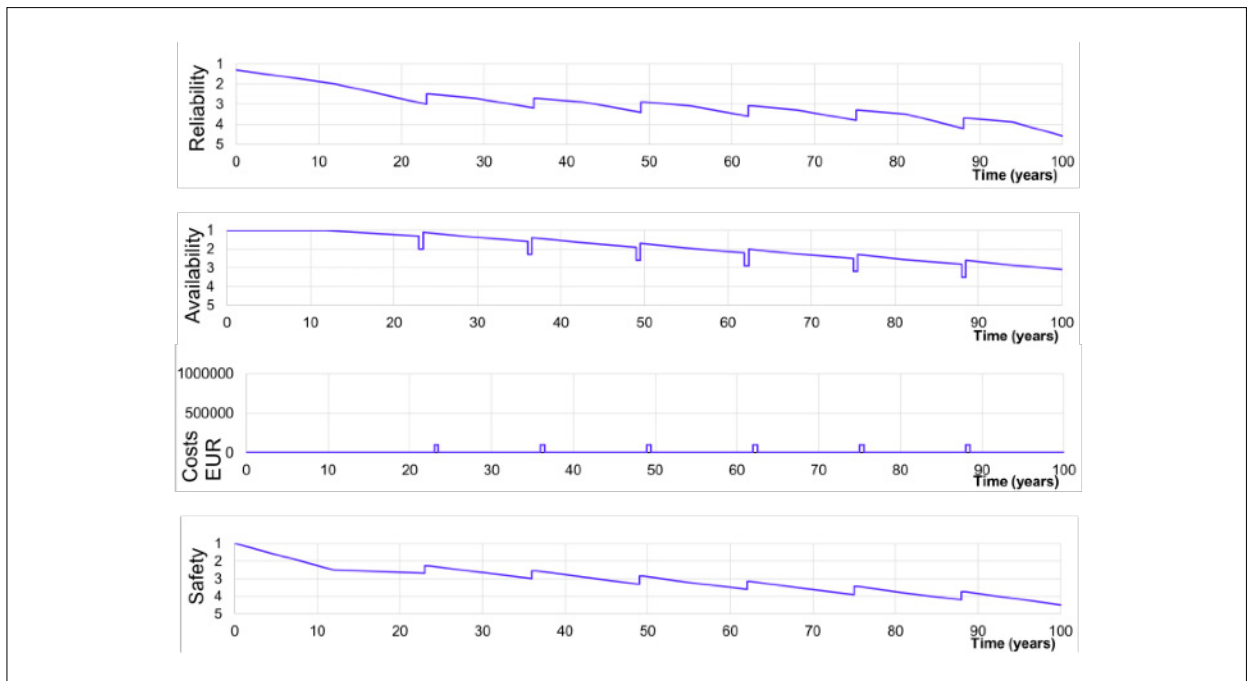

Figure 29. Evolution of Key performance Indicators under Scenario 2

Scenario 3 considers preventative bridge maintenance through many relatively small repairs and activities to keep the bridge in a good condition and thereby avoiding large expanses in major rehabilitation or replacement. The effects of preventative maintenance actions were modeled through a delay of a degradation process for a period of time t_{PD} immediately after application of the action, without any improvement in reliability index.

This type of maintenance is a cyclic maintenance, where typical activities are taken in planned intervals. Here, preventative actions were assumed to be taken over 6 years delaying the degradation of the reliability with a time duration of 3 years (**Figure 30**).



Figure 30. Semi-quantitative performance indicator reliability for Scenario 3

Availability was assumed to decrease over time with a small improvement immediately after the preventative action. Minimum costs for these actions were considered. User safety is decreasing faster than the reliability level. The overall condition is illustrated in **Figure 31**.

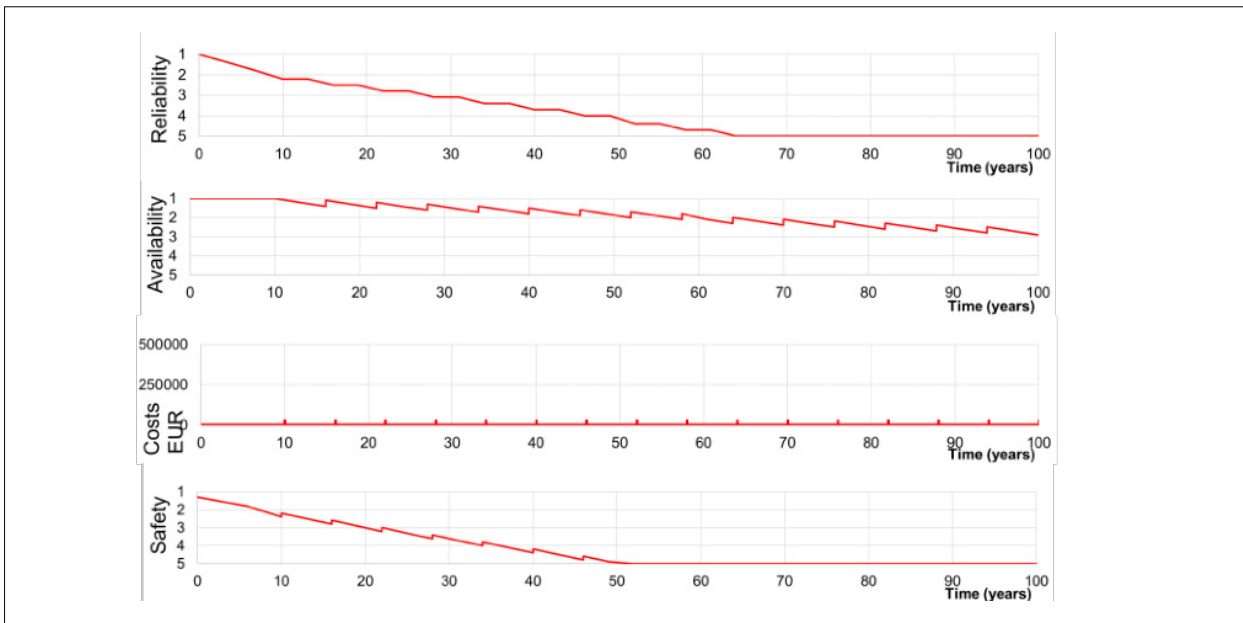

Figure 31. Evolution of Key performance Indicators under Scenario 3

Figure 32 considers the reliability indices estimated for all three scenarios, while **Figure 33** presents a four-leg spider diagram with present values for KPIs for each scenario. The corrective maintenance scenario is observed to be the most appropriate one in this case with the largest spider area.

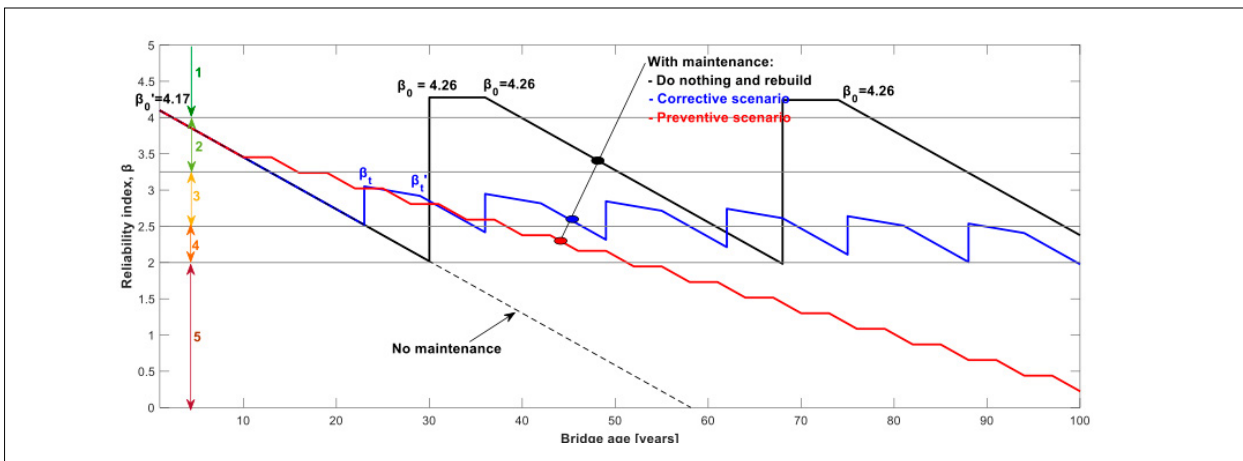

Figure 32. Semi-quantitative performance indicator reliability for all Scenarios

Comparison is also made in terms of the spider diagram's area (Figure 34) and volume (Figure 35) at each point of time. The volumes of the spider diagrams are estimated for the bridge life time of 70 and 100 years. Right before the second replacement of the bridge in the "do nothing" scenario (at 70 years), the largest spider volume has the corrective approach, while the approach consisting of only preventative actions has the smallest volume.

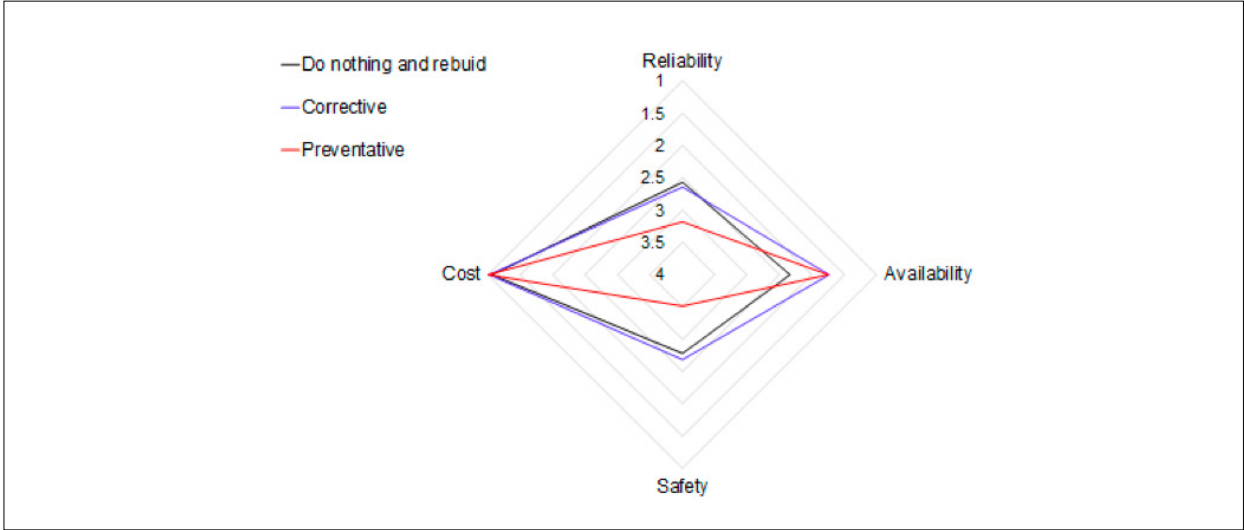

Figure 33. Comparison of the net present key performance indicators for the considered maintenance scenarios.

For 100 years life time, the largest volume is aligned to the scenario of "do nothing and rebuild". The main difference between each of the considered scenarios is the cost of the actions, which becomes similar after the normalization. This normalization is probably responsible for the bigger volume of the "do nothing and rebuild" scenario for the life time of 100 years. The comparison of the spider diagram areas and volumes computed are presented in Table 5.

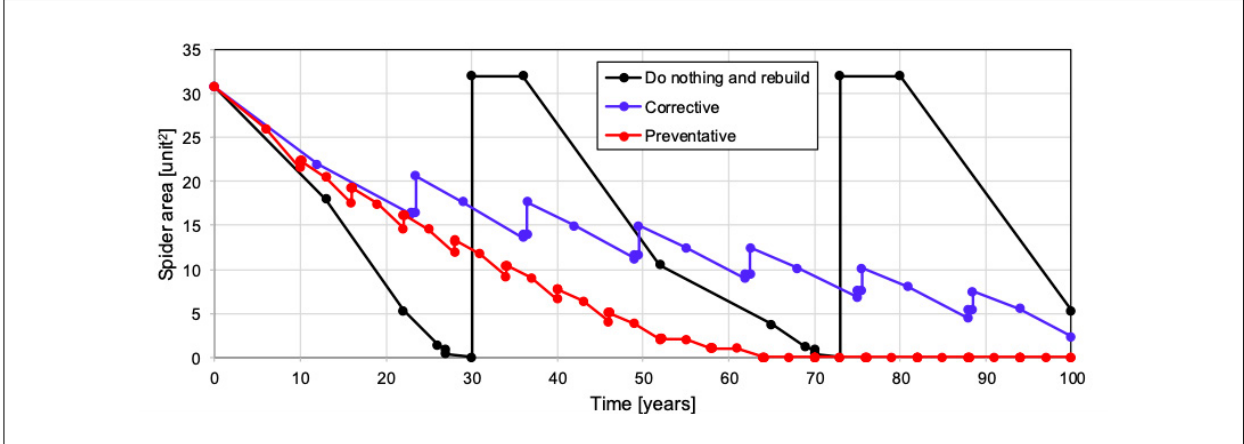

Figure 34. Comparison calculated spider diagram area for all scenarios considered.

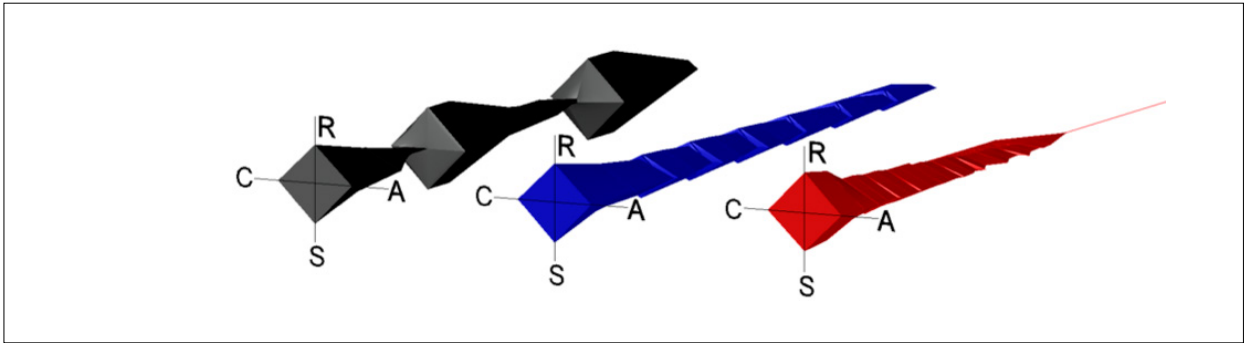

Figure 35. Comparison of 3D spider diagrams for all scenarios considered.

Maintenance scenario	Spider Area [unit ²]	Spider Volume 70 years [unit ³]	Spider Volume 100 years [unit ³]
Scenario 1	15.34	1037	1646
Scenario 2	16.89	1184	1389
Scenario 3	11.96	780	780

Table 5. Effectiveness of each scenario in terms of the reference one

4.3. IMPLEMENTED CASE STUDY 3: STEEL TRUSS BRIDGE, ISRAEL

A 36m single-span half-through steel truss bridge structure with reinforced concrete slab built in 1956 is considered (Figure 36). The bridge carries road no. 9779 across the Jordan river between Qiryat Shmona and the Golan heights, Israel. As per 2012, the average annual daily traffic is 6800 with no information on heavy vehicles. The bridge is frequently crossed by heavily loaded army vehicles. Foundations are inaccessible, but the historical existing drawing shows mass reinforced concrete abutments with four rows of hammered piles penetrating into the concrete foundation of the abutment.

The material of pile is not known but taking into account the year of construction 1956 it can be either steel or wood. The substructure is formed by two abutments made from reinforced (discovered during investigations) massive concrete with deadman block at the back tied by tension buried girders.



Figure 36. General information of the case study truss bridge and related damages.

The superstructure is composed of 36 meters long half through riveted steel truss divided into ten bays each 3.6-meter long. Two parallel trusses with centreline distance of 6340mm are connected at the bottom cord by eleven rigid transvers cross girders with 810mm depth forming a U shape rigid deck structure. The transverse girders are preventing the longitudinal global buckling of the trusses. Reinforced concrete deck with variable depth of 330mm to 270mm and constant width of 5570mm is connected rigidly onto the transvers girders. The slab is continuous over the transvers girders. The deck slab is paved with 60mm asphalt pavement layer. The pedestrian walkway is made of reinforced concrete elements and the pedestrian safety rail is made of steel. Bearings are pinned on the east side and longitudinal movable double rollers on the west side.

The original expansion joints are buried under the current asphalt layer thus preventing the functioning of the roller bearings. Due to the 2011 inspection findings showing excessive dynamic response to vehicles crossing the bridge, the load capacity of the bridge was immediately reduced to 40ton as a safety precaution. This condition caused severe problems as the road is frequently used by heavy military and agricultural vehicles. Dynamic load testing and temporary structural monitoring were initiated in order to try and locate the source of the increase vibrations. The theoretical capacity of each steel element composing the bridge was checked according to the Israeli bridge code IS1227 (based on the British old code BS5400) for HA, HB & HC loads and found to be satisfactory.

Due to the 2011 inspection findings, a concern raised regarding the integrity of the riveted lower connection of the transverse girders with the main truss bottom chord and truss vertical elements. A FEM calculation model was set, and the model was checked for: A. monolithic connection between the transverse beams and the truss (as designed); B. releases in between two transverse girders and the truss; C. releases in between four transverse girders and the truss and D. releases between all transverse girders and the truss. Checks for buckling and lateral sway for relevant locations and forces were carried out and the results indicated that the overall stability of the truss is related directly to the degree of the fixing of the lower cross girder connection with the truss.

According to the Israeli bridge condition rating system the status: i) CPlav=72 meaning the structure is in poor to fair condition with moderate to severe damages and possible severe influence on one or more of the bridge or element performance; ii) CPlcrit=55 meaning possible failure of an element with severe defect or damage reducing the load carrying capacity. (taking into account the NDT done later this score will be reduce to 28) and iii) SVIb = 66 meaning the Seismic Vulnerability Index is classified as second grade and an action should be taken in the near future for seismic retrofitting of the bridge. The vulnerable zones were identified in: main truss and cross girder to deck connection.

The main types of defects discovered on the bridge inspection are: 1. Increased vibration of the bridge during vehicle passing; 2. Mild corrosion of structural steel; 3. Excessive relative movement of rivet head in many locations; 4. Out of plane deformation of steel plates at the bottom girder to truss connections; 5. Concrete deterioration mainly at the deck slab edges and in some locations at the wing walls and abutments; 6. Deterioration of the concrete closing wall behind the roller bearings at abutment A; 7. Accidental damage due to collision of vehicles with main truss vertical and diagonal members; 8. Defects of pavement mainly near the expansion joints; 9. Deck waterproofing not functioning (or missing); 10. Inefficiency of deck drainage; 11. Deterioration of steel handrailing and collision damages; 12. Non-functioning roller bearings; 13. Limited rotation of the pin bearings due to corrosion damages and 14. Horizontal cracking in layers at abutment.

The identified failure modes for Ultimate Limit State (ULS) are: i) Local failure of truss members and riveted section disintegration due to sheared rivets (fatigue); ii) Global bridge failure due to loss of stability of the truss and lateral buckling under heavy live load as a result of transverse girder to truss connection rivet failure (limiting the sway restraint of the main truss by the transverse girders); iii) local failure of truss vertical and diagonal members due to accidental load from heavy load transportation vehicle as a result of non-functioning safety barrier. This may lead to global truss vertical direction failure (depend on the location of the heat and the member); iv) transverse girder bending/shear failure – due to excessive dynamic effect of heavy vehicles crossing the bridge and v) failure due to Seismic loading (the bridge is located at high seismic zone) and SVIb value is low showing that the bridge needs seismic retrofitting action in short time.

The identified failure modes for Serviceability Limit State (SLS) are: i) main Safety Barrier failure – due to accidental load from heavy load transportation vehicle; ii) pedestrian Safety handrail failure – due to increased corrosion at the edge and soffit of the pedestrian concrete pathway and loss of anchoring of the handrail vertical members; iii) bearing failure – loss of functioning of the roller bearing and rotation of the fixed bearings due to corrosion and accumulation of debris; iv) asphalt pavement failure – due to nonfunctioning Joints and drainage and v) concrete curb failure – possible falling of concrete chunks over the Jordan river where tourists are using boats.

Rivet Ultrasonic Testing was carried out on 405 rivets following reports on irregular rivet alignment in many locations over the main truss members and the cross girders. The results were classified into three categories: Category A - no specific indication result; Category B - suspected rivet where the indication might be a sign of manufacturing defect or other minor defect and the result does not influence critical elements; and Category C - clear evidence that the rivet is defective. In these tests, 44 were classified as Class B and 9 rivets were classified as Class C. All class C rivets and some of the class B rivets were located at the bottom transverse girder to truss connection.

Due to the inspection findings indicating that the vibration of the bridge during heavy vehicles passing is excessive, dynamic measurements were conducted with accelerometers in order to find vibration modes of the bridge and compare with the calculated values. Also, the damping coefficient and the influence of a moving truck were calculated. A 600 KN full trailer truck traversed the bridge in 10-60 km/hour and 25km/hour speeds and the effect of emergency braking was also measured. The fundamental frequency was observed to be $3.8\text{Hz} \pm 0.05$ (related to movement in vertical direction), the damping ratio was estimated as 1.2% - 1.4%, while the lateral fundamental frequency of the truss in some cases was 10Hz.

Key performance indicators were chosen in accordance with best practice knowledge and experience with bridge inspection in Israel. Two life time cycle approaches are considered for 100 years.

Scenario 1 considers a lack of any repair of the bridge except very basic ones on the pavement. The bridge defects evolve until component or system failure and a comprehensive intervention is performed for the relevant component or system only while others continue to deteriorate. The pavement failure in five years is considered due to crack development over the expansion joints and creation of potholes which will reduce the safety of the driver and also might increase the probability for accidental impact load hitting the main truss members. Collapse of steel safety barrier is considered in 10 years due to possible accidental damage. Failure of the connections of the truss vertical members with the cross girder is expected in 15-20 years due to the influence of the fatigue on the rivets and it is expected (based on the actual defects found already) that this phenomenon will progress in time. The influence of corrosion development on the different components of the bridge is predicted to reach in 30 to 40 years' time based on the site climate and the current corrosion state. Spalling at the bottom of the slab edges and at the curbs is predicted to develop into unsafe condition to the users of the boat service passing below the bridge in 15-20 years. The anchoring of the pedestrian handrail is deteriorating due to corrosion and expected to fail in 30-year time. **Figure 37** presents the evolution of various parameters for this scenario.

Scenario 2 takes a preventative approach where a first major rehabilitation of the bridge and a later periodical set of timely interventions during the life time cycle is considered to prevent further defect development and overall damage. Seismic retrofitting needed is not included in this scenario. The intervention is considered in the next two years after the design and following this massive intervention, a preventive intervention regime is established with 10 years, 20 years and 40 years periodical intervention.

The immediate bridge rehabilitation includes: complete concrete elements repair, concrete curb replacement, joints connection repair including about 400 rivets replacement and plate replacement, overall bridge painting, new expansion joints, bearing rehabilitation, replacing safety barrier with new one including end blocks, rehabilitation of the pedestrian handrails, pedestrian deck overlay, new waterproofing and asphalt overlay.

The 10 years intervention includes: Upper layer asphalt paving and safety barrier rehabilitation (based on the actual accidental incidents that will happen during that time. The cost includes the temporary traffic arrangement needed.

The 20 years intervention includes: 10 years intervention + overall concrete surface treatments, overall painting system renewal, In depth NDT of the truss connections (before repainting), EJ rehab./replace, The cost includes the temporary traffic arrangement needed.

The 40 years intervention includes: 20 years intervention + rivet replacement (estimated 500 units), Bearings rehabilitation/replacement, renewal of deck waterproofing system. **Figure 38** presents the evolution of various parameters for this scenario.

The cost includes the temporary traffic arrangement needed. The estimated failure time is assumed as per team experience with steel and concrete structures in Israel and estimated progress of the defects.

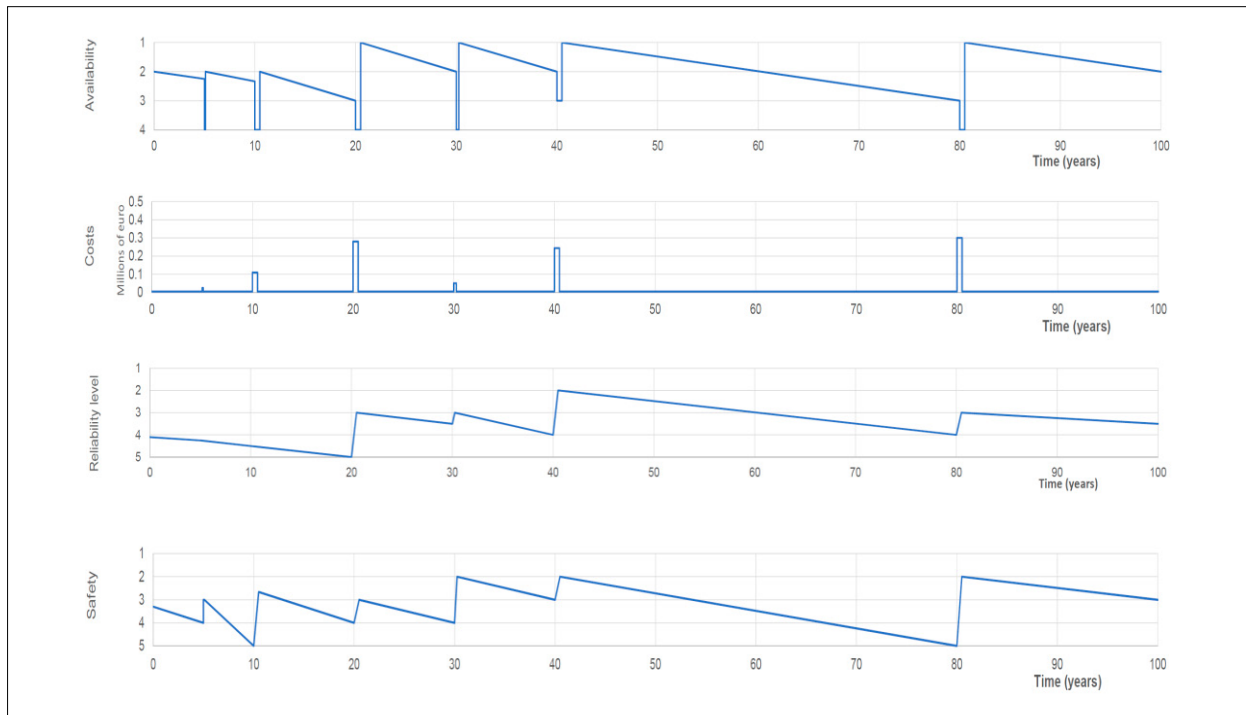

Figure 37. Evolution of key parameters under Scenario 1.

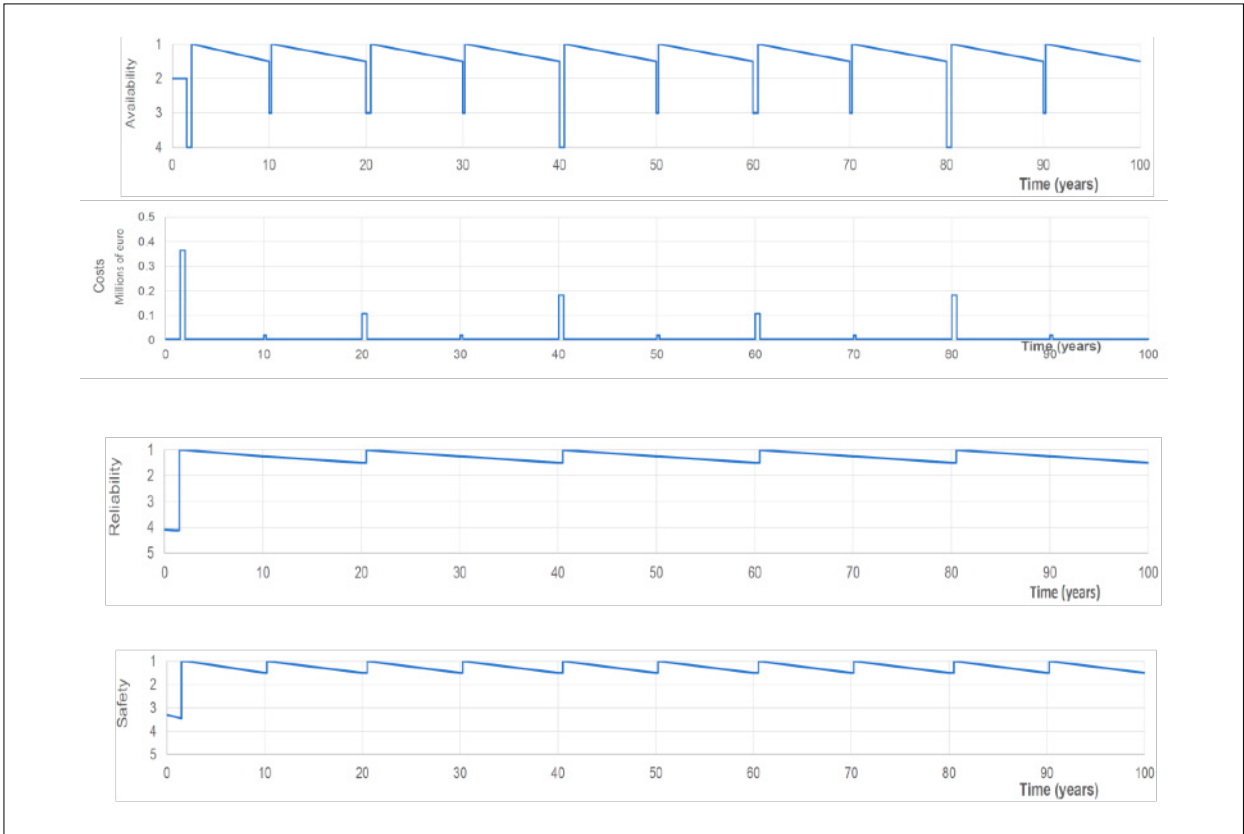

Figure 38. Evolution of key parameters under Scenario 2.

A comparison of the two considered approaches is shown via the Spider Diagram (Figure 39) proposed in COST TU1406. According to the analysis the preventative approach is clearly more appropriate for this truss bridge - The cost is little more but all other indicators shows more favourable results for all aspects. The reliability and safety are kept in higher levels all over the period.

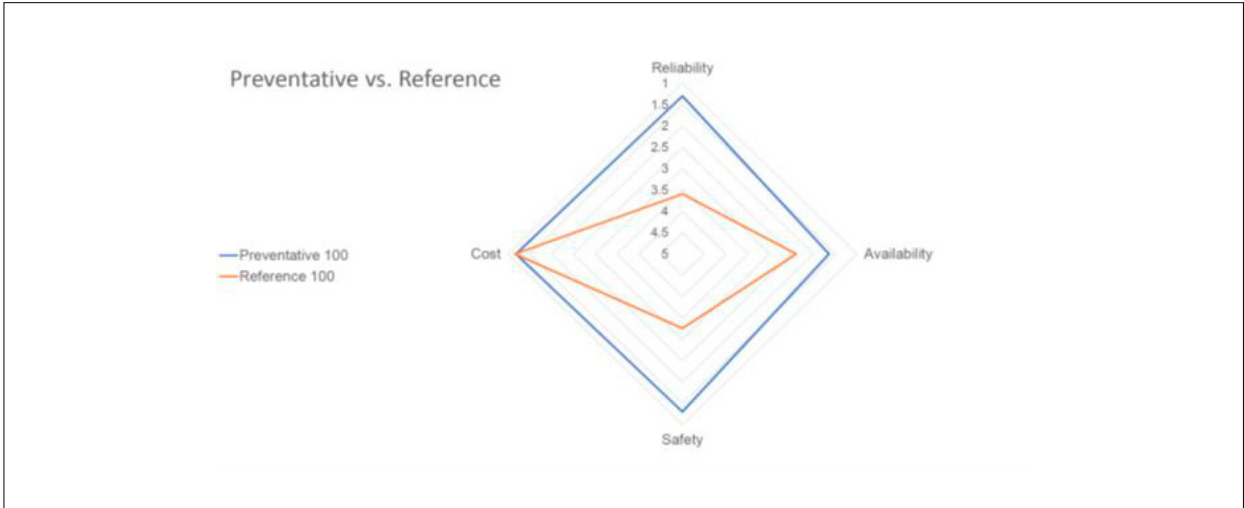

Figure 39. Spider Diagram comparing five maintenance scenarios.

5. CONCLUSIONS AND FUTURE WORK

5.1. SUMMARY OF GUIDELINES AND RECOMMENDATIONS

As observed in this section, each WG has led to specific guidelines and recommendations. A summary of these are provided below.

5.1.1. KEY GUIDELINES AND RECOMMENDATIONS FROM WG1

WG1 emphasizes the importance of defining a holistic framework for road bridge asset management with diverse requirements and responses around safety, stability, serviceability, functionality, durability, cost-effectiveness, environmental impact and socio-economic factors. Identifying and defining correct individual and combined performance indicators (PI) around safety, user-needs, environment and socio-economic aspects is key to such a holistic framework, which WG1 addresses by developing a database of observations and performance at component, system and network levels by extensively analysing information on PIs in EU countries. This can be extended to develop into a unified database, benefiting from rapidly evolving Inspection and Structural Health Monitoring (SHM) techniques. The European PI database is grouped into (i) operators' PI database and (ii) research-based PI database.

For Operational Database, more work is necessary to identify key PIs, along with the Research-based one for achieving PGs for optimal Quality Control Plan and to allocate them with appropriate weights related to their respective levels of importance. The following steps are recommended to select the most important Performance Indicators:

1. Define crucial Performance Goals
2. Categorise Performance indicators in relation to Performance Goals
3. Consider the following qualities for selecting a PI: a) measurability, b) quantifiability, c) availability of target value, d) validity for ranking purposes and e) applicability in making economic decisions.

5.1.2. KEY GUIDELINES AND RECOMMENDATIONS FROM WG2

Performance Goals (PG) are distinguished from PI and the recommended approach follows the reversed order of the process in RAMS analysis (MAHBOOB AND ZIO, 2018), which defines the end functions through setting goals and subsequently developing more detailed indicators. This is often combined with performance-based design and allows for inverse verification.

WG2 connects PIs to PGs at component, system and network levels. A multi-objective approach is recommended to address diverse PGs of a stock of bridges.

Five performance aspects are selected in this regard:

1. Reliability
2. Availability
3. Safety
4. Cost
5. Environment

A multi-criteria decision-making (MCDM) approach can systematically combine the inputs with cost-benefit models to rank available decision options about the bridges at component, system or network levels. A web-based Multi-Attribute Utility Theory (MAUT) developed in WG2 is recommended to be useful in this regard (https://maut.shinyapps.io/application_of_maut/).

To integrate network and structure performance requirements, it is recommended to acknowledge challenges in linking PGs with PIs, translation from network (often broadly defined) to system level (often specific and not linked to network level) and vice-versa, along with the establishment of a complete set of PIs. Future developments can attempt to unify a) standardization of the assessment procedures, b) further collection of PIs and quantification of KPIs and c) implementing bespoke and robust maintenance tools to be used in practice.

5.1.3. KEY GUIDELINES AND RECOMMENDATIONS FROM WG3

WG3 presents a QC framework while acknowledging the diversity in their application in practice. The recommendations and guidelines thus attempt to retain the individuality and variability of road bridge maintenance approaches in different networks as much as possible. As a definition of quality, WG3 considers the fitness for purpose, degree to which a set of inherent characteristics of a product/service fulfils requirements and the service delivery process (costs, societal and environmental aspects). The quality control plan defines the extent and the interval of inspections or investigations and data necessary to estimate key performance indicators (KPI), forecast future development and suggest maintenance actions, overlapping with the Strategic Asset Management Plan (SAMP) and Asset Management Plan (AMP) as defined in ISO 55000. Evaluation of KPIs from performance indicators (PIs) still require several discussions to resolve all outstanding issues and aspects like Reliability and Availability seem to be overlapping sometimes. KPIs like health, politics and maintainability are difficult to assess at least on a bridge level.

WG3 presents and recommends the use of a Spider Diagram for QC, by quantifying the overall performance related to the area in the diagram enclosed by KPI values, for a single or a collection of bridges. The KPI is qualitatively quantified between the ordinal scale of

1-5 (1 being the best and 5 being the worst). The most relevant KPIs should be selected for use in a particular situation. When assessed over time, the Spider Diagram forms a tube. The various KPIs can be expressed in their native units and then normalized to obtain their integer values.

Within a QC framework, the KPIs will be evaluated for different maintenance scenarios (based on inspection/investigation or prediction), looking for the most feasible one. KPIs of Availability, Economy and Environment can be only reasonably applied as a function of time. Damage processes, defined as independent of combined actions having a detrimental effect on a bridge can be crucial for performance prediction, preventative maintenance and eventual rehabilitation. Information on damage can be obtained from inspection and testing. Impact of natural hazards on bridges is yet to be included in BMS but should be considered to understand consequences.

Modern codes define both safety and serviceability in terms of reliability index but estimating them for bridges can be tedious and complex. Based on experience and available data, a simplified reliability assessment can be performed which can be adequate for assessment.

The QC framework has a a) static and b) dynamic stage. The steps for a static (snapshot) quality control comprise: 1. Preparatory work (inventory, conceptual weakness of design, material weakness, traffic load changes, identification of vulnerable zones, estimating a priori reliability); 2. Inspection on site (damage detection, material property measurement, sample collection); 3. Laboratory tests; 4. Assessment of the Reliability KPI (resistance reduction estimates, reliability estimates); 5. Assessment of the Safety KPI.

The steps for a dynamic quality control comprise: 1. Assessment of remaining service life (damage speed and forecast, time dependent safety and reliability); 2. Maintenance scenario (reference scenario - end of service life, preventative scenario, long term cost, availability and reliability/safety estimates for scenarios); 3. Decision making (multi-objective/attribute optimization, monetize, non-monetary KPIs, find optimal scenario).

Diverse inspection methods exist and for bridges in a good condition, visual inspections are sufficient to determine the values of their KPIs, while for other cases additional investigations are necessary. For a QC plan, an inspection protocol is needed to ensure that the inspection data and the decision processes are at or above the desired level of reliability. It is not possible to develop an inspection plan that addresses requirements, procedures, practices and trainings to an extent where the data gathered, and the decisions taken will have perfect precision. An element of interpretation in the inspection results will always be present and will therefore allow certain variations in the decision making. This can be greatly reduced using an appropriate protocol. A bridge inventory data should be available in the Bridge Management System (BMS) together with relevant parameters/data that are not strictly related to the structural type but are needed for establishment of QC procedures. The following data is relevant:

Data on previous inspections/interventions; Bridge age; Clearance; Environmental conditions; Traffic and Inspection and maintenance aspects (incl. costs).

5.1.4. KEY GUIDELINES AND RECOMMENDATIONS FROM WG4

The implementation of guidelines and recommendations are carried out in WG4. The steps to be followed for implementing it on a bridge, is recommended in Table 6, which has been the basis of implementation in WG4.

No.	Task Name	Description of the work to be done	References*
1	Collect existing data and prepare ID/Birth Certificate	Prepare inspection by collecting existing data. Prepare/update a bridge ID/ birth certificate as per the format given in chapter 12 of this document. This information is relying on inventory data (If exist) and additional data acquired on site.	Chapters 2, 4 and 12. WG3 Report: Clause 12.1, Clause 8.5
2	Identify bridge elements	Identify all bridge elements and prepare a bridge element table using the defined taxonomy of TUI406. For each element document the dimensions and dimension units. Existing element list per country current practice can be transformed into the suggested format.	Chapter 4 and 12. WG3 Report: Girder & Frame Clause 8.1, Arch bridge: Clause 9.1 Example: Clause 8.5 Dimensioning: Clause 7.4
3	Elements grouping & segmentation	Arrange bridge elements by grouping together. Grouping can be according to different criteria such as geometry, functionality, materials, exposure etc.	Case studies examples: Appendix A1 to A17
4	Identify failure modes	Use design documentation and define failure scenarios. For each scenario identify the possible failure modes, for example: rigid body movement (loss of stability), internal mechanism (shear, bending, ...), fatigue, functionality, comfort (to the user), visual appearance (to community), safety (falling parts) etc.	Chapter 5 WG3 Report: Clauses 8.3, 10.4.4, 10.4.5 Case studies examples: Appendix A1 to A17
5	Define vulnerable zones	Check for existence of conceptual weaknesses in the specific bridge type. Define and document the vulnerable zones on the bridge and correlate with the relevant failure mode. Documentation should include plan, elevations and sections as needed with marked positions of the zones and the relevant failure mode using WG3 defined labels.	Chapter 5 WG3 Report: Girder & Frame Clause 7.2 Arch bridge: Clause 7.3 Case studies examples: Appendix A1 to A17
6	Evaluate virgin reliability	If quantitatively approach is selected, asses the "Virgin" reliability of the bridge using prototype and specific bridge, historical design data. Simplified or more precise models can be used.	Chapters 4, 8 WG3 Report: Clause 6.3, Clause 12.2,

7	Bridge Inspections	Perform on site visual bridge inspection with/without testing or monitoring. Inspection should be done taking into account the specific recommendations defined for the bridge prototype and the previously defined vulnerable zones and identified failure modes. Possible hidden defects/damages should also be investigated. Damages should be identified, compared with previous inspection results, documented and quantified by severity and extent. Documentation should follow WG3 report recommendations. The need for in depth investigation should be checked. Following the inspection, update the failure modes and vulnerable zones data from stages 4 and 5.	Chapters 6, 8. WG2 Report: Clause 3.1.4 WG3 Report: Clause 3.2, Clause 7.2.5, Clause 7.4 Example: Clauses 8.5, 9.2 Chapter 11 Case studies examples: Appendix A1 to A17
8	Identify damage processes	Identify the damage processes on the bridge using the information collected during the bridge inspection and the predefined proposed damage processes as per WG3 report.	Chapters 7, 8. WG1 Report: Clause 4.2.1.1 WG3 Report: Chapter 4, Clause 5.2 Case studies examples: Appendix A1 to A17
9	Select PI for the bridge and connect with KPI	Select the appropriate PI and connect to relevant KPI considering the observations and connect with the damage processes (see WG3 report table 5.3).	WG3 Report: Chapter 5, Clause 5.2, table 5.3 Case studies examples: Appendix A1 to A17
10	Evaluate PI	Relevant PI should be selected for the bridge prototype (WG3) and for the specific bridge considering the specific scheme, materials and possible sudden events. The PI should be evaluated using predefined thresholds as per the owner demands (normally defined in the national professional guidelines).	WG3 Report: Clause 7.5, table 5.3, Clause 10.4 Examples: Clause 8.5, 9.2 Case studies examples: Appendix A1 to A17
11	Assessment of KPI	Qualitative assess the resistance reduction based on the observed damages. Evaluate reliability and safety KPIs based on agreed methods ranging from simple "Engineering Judgment" to complex Bayesian Nets. Use suggested WG3 QCP protocol for performance evaluation and derivation of the KPIs from PIs. All KPIs should be normalized. Cost should be scaled based on the maximum yearly cost of all scenarios.	WG2 Report: Chapter 3 WG3 Report: Clause 7.5, table 5.3, Clause 10.4 Examples: Clause 8.5, 9.2 Clause 12.2 (scale) Case study example: Appendix A7 clause 3.1
12	Define Deterioration processes and timing (time to failure)	Following the evaluation of the different PI and KPI assess the remaining service life i.e. the point in time at which Reliability or Safety will reach the defined threshold value (unacceptable return period for a failure) without any intervention. This includes assessment of the speed of the identified active deterioration processes and damage forecast. For each documented damage, indicate the relevant damage process and estimate the time to failure and document on the PI/KPI evaluation table. The assessment can use known existing models for deterioration in time or simple expert opinion.	Chapters 8, 9. WG3 Report: Clause 7.5, Clause 7.10, Clause 8.3 Examples: Clause 8.5 Case studies examples: Appendix A1 to A17
13	Define Inspection/tests/monitoring plan	For the reference scenario and for other preventive scenarios define the inspections type and intervals. For each inspection define the cost (as annual cost). Estimate the future type and timing for NDT/DT testing and monitoring with the related costs.	Chapter 10. WG3 Report: Clause 11.2, table 11.6, clause 12.1
14	Define maintenance and other	Define several maintenance scenarios with target reliability and safety over time. Define the time frame (for how many years). Estimate the cost of the different interventions per each scenario over time and combine with the costs estimated on stage 13. Define the function of decrease of Reliability and safety. For each scenario create graph per KPI (R, E, A, S) over time (excel file of WG3 can be used). All KPIs should be normalized (range 1 to 5).	Chapter 10. WG3 Report: Clause 7.5, Clause 7.6, Examples: Clause 8.5, 9.2, tables 12.1 to 12.4 Case studies examples: Appendix A1 to A17
15	Create Spider	Create Spider diagrams of net present KPI for the scenarios and compare. This stage can be done for single point in time (spider) comparing the areas of the different scenarios spiders or as a continues process with preparation of 3D volume shape showing the change of the KPIs over time (few spiders). In such case the volume of the 3D shapes created for the different scenarios should be compared.	Chapter 10 and Appendix A1 to A17 WG3 Report: Clause 7.5 Examples: Clause 8.5, 9.2,
16	Export data to Network level analysis	Part of the data should be used for "Network level analysis". The data format and the decision regarding the needed parameters rely on the network analysis method. A possible example using "Multi-objective optimization models" is given in WG2 Report.	WG2 Report: Chapter 5

Table 6. Stages of implementation process.

*Note: references are coloured by WG 1-3 and this report. (WG1 = Orange, WG2 = Blue, WG3 = Green, This document = Black)

5.2. ASSUMPTIONS AND CHALLENGES

The following assumptions and challenges exist for the work carried out:

- i.* There are significant variation and lack of data availability and sharing from bridge networks and their management.
- ii.* There are significant financial and resource crunch constraints for all bridge networks.
- iii.* Training of inspectors are variable.
- iv.* For preliminary or approximate estimates of reliability, the experience and engineering judgement of the consultant is relied upon and this can have human variability in them.
- v.* For damage processes, the assumptions made about the type and rates of changes of damage need to be better calibrated and quantified by inspections and destructive/non-destructive testing.
- vi.* Definitions around terminology, performance indicators and goals are still not entirely homogenized.
- vii.* Understanding of uncertainty and reliability is further required in industrial scenarios.
- viii.* There needs to be more demonstrations and direct benefits for the owners to implement the more holistic approach considered in this Action.
- ix.* There is a need to continue the ongoing work beyond COST TU1406.

5.3. ONGOING WORK

The following summary and related ongoing work were considered for this Action:

- i.* the Action was extremely successful in a) understanding b) documenting and c) assessing the approaches taken for Road Bridge infrastructure in EU and around the world (e.g. USA, India, Australia, Russia etc.) and collating such information.
- ii.* experiences and limitations from bridge owners and managers from various countries were documented
- iii.* the definitions and deep understanding of key governing terms were better clarified, key performance indicators and their measurements were better established and expanded through the action
- iv.* this concerted effort led to an overall approach developed in the Action for assessing road bridges, for which we now have a comprehensive set of case studies using several countries around EU as a demonstration and covering a wide range of road bridges to create a technical evidence base
- v.* several workshops and training sessions were organized to diffuse and disseminate the results, along with publications of several conference and journal papers in reputed places
- vi.* at the end of the Action we are able to recommend, guidelines for best practice in maintenance and management of Road Bridges. The guidelines will harmonize (note: not homogenize) in EU the principles, approach and methodology based on which their maintenance and management will be carried out while retaining the disparate implementation and levels of data that is currently present in different countries in the presence of resource and funding constraints.
- vii.* as a follow-up implementation, we have created Infrastruct as a first platform for the advancement of such actions through industrial leadership and academic collaborations to provide the bridge managers and owners a platform to discuss, decide and develop further activities in future for safer Road Bridges.
- viii.* in order to diffuse the work done by the Action into normative documents we have been liaising closely with relevant bodies (ISO, CEN) to identify and follow-up the scope of contributing to their activities from our results and findings. In this relation, we believe that JCSS can be an important partner to liaise with.

5.4. VISION FOR FUTURE

The following visions for the future are considered:

- i.* Utilizing EuroStruct as the main platform for continuing the dialogue and the work from COST TU1406.
- ii.* Continuing dissemination from follow-on projects using collaborative groups from the Action.
- iii.* Establish strategic and targeted vision for leasing with normative bodies to establish a standardization pathway. This is expected to be achieved in the Iceland Workshop in April, 2019.
- iv.* Host conferences to allow the road bridge infrastructure owners to come together on a common platform to encourage them to share experiences and information.
- v.* Homogenising the methodology for road bridge infrastructure maintenance and management in EU.
- vi.* Extending the impact of COST TU1406 to other countries via collaborative research and commercial work.

Overall, the expectation is to best understand, implement and optimize the decisions making framework in a homogenised way within EU.

6. TERMINOLOGY

6.1. CONTEXT TO TERMINOLOGY

While the overall approach of bridge management in various networks are similar, their operational aspects can significantly differ. This difference is amplified by the fact that there is a gap of a homogeneous terminology in EU when it comes to road bridge management. While this is expected in a geographic region with several languages, there is a need to collect, understand and homogenise key terms around road bridge management and agree on their definition.

This task is complex, but can reap significant benefits, especially when the aspiration in future is towards a common framework for maintenance and management. The homogenisation avoids confusion and leads to a clearer understanding of the processes and the implementation of a quality control framework. This gap around homogenisation of terminology and definitions remains is yet to be bridged.

6.2. ACTIVITY IN COST TU1406 ON UNDERSTANDING TERMINOLOGY

COST TU1406 particularly focused on addressing this gap through the activities of WG1 and its links with WG2. The work also formed the basis to contribute to pathways to standardisation and liaison with normative bodies. A questionnaire based technical survey was planned among the participating countries to obtain information around this. Research documents and performance indicators already in use by the highway agencies along with those still in a developing stage were considered.

A network of experts was chosen from different stakeholders (universities, institutes, operators, consultants and owners) and from various scientific disciplines (e.g. on-site testing, visual inspection, structural engineering, sustainability, etc.). It was observed that in most countries, the performance of bridges are good and consequently a homogenisation of indicators and definitions was based on current practices and involving activities that leads to minimum disruption of such practices.

Pre-defined performance indicators were drawn up and country specific documents were scanned to mark phrases associated with such performance indicators. This led to an extensive set of definitions and indicators that were aligned with each other for various countries. WG2 worked closely with WG1 and developed a set of performance

6.3. KEY DEFINITIONS AND TERMINOLOGY

Key definitions and terminologies related to COST TU1406 are selected and presented in this report below, as a result of the activities of WG1 and WG2. For details and sources of such definitions and terminology adapted to COST TU1406, the final reports of WG1 and WG2 are referred to.

Asset management: coordinated activities of an organization to realize value from assets; Realization of value will normally involve a balancing of costs, risks, opportunities and performance benefits.

Damage: disruption or change in the condition of a structure or its components, caused by external actions, such that some aspect of either the current or future performance of the structure or its components will be impaired. The unfavourable change may refer to mechanical properties of construction materials and/or to geometrical properties of a structural system (including changes to the structural members, member connections, and supports).

Deterioration: Worsening of condition with time, or a progressive reduction in the ability of a structure or its components to perform according to their intended functional specifications.

Deterioration mechanism: Process of the cause and development of deterioration (Scientifically describable).

Damage detection: Process of ascertaining whether the damage to structure exists or not. Three main approaches in damage detection are visual inspection, non-destructive testing, and structural health monitoring.

Damage identification: In addition to damage detection and characterization, damage identification includes ascertaining the cause of the damage and its consequences.

Lifecycle cost (LCC): Cost of an asset or its parts throughout its lifecycle, while fulfilling its performance requirements.

Performance assessment: A set of activities performed to verify the reliability of an existing structure for future use.

Performance criteria: Quantitative limits, associated to a performance indicator, defining the border between desired and adverse behaviour.

Performance evaluation: Process of determining measurable results.

Performance goal: Type of structure property (behaviour) that is required based on assessment of different performance indicators.

Performance index: An assessed parameter of the bridge, dimensionless number or letter on a scale that evaluates the parameter involved on an X to XN scale, X being a very good condition and XN a very poor one.

Performance indicator: A superior term of a bridge characteristic, which indicates the condition of a bridge. It can be expressed in the form of a dimensional performance parameter or as a dimensionless performance index. Measurable/testable parameter (i.e. characteristic of materials and structures) that quantitatively describes a performance aspect.

Performance level: Qualification of a structure or a structural element, which is established by verifying its behaviour against the performance requirements. A satisfactory performance level is reached when a structure or a structural element has demonstrated a sufficient behaviour to meet the performance requirements. In the opposite case, the performance level of a structure or a structural element is considered to be unsatisfactory.

Performance threshold: A value that constitutes a boundary for purposes such as: a) monitoring (e.g. an effect is observed or not), b) assessing (e.g. an effect is low or high), and c) decision-making (e.g. an effect is critical or not).

Reliability: The probability that a system or component will meet its performance requirements under given conditions and during a given period of time.

Repair: Improvement of the conditions of a structure by restoring or replacing existing components that have been damaged.

Risk: The risk refers to danger, hazards or loss of chance in an uncertain venture, and is defined as the product of the consequences of failure (Consequence of failure, COF) and the probability of entering this failure (Probability of Failure, POF).

Safety: In contrast to Risk, Safety is term used to describe a condition in which the risk is on an acceptable level.

Risk-based Inspection (RBI), Risk-based Inspection Planning (RBI): Procedures for the evaluation of system areas and their components as well as of their associated inspection concept from a risk perspective in terms of safety, availability and cost (see also risk). Objective of RBI is to optimize the inspection intervals and consequently the maintenance costs while ensuring the required safety levels during operation of the system.

Service life: Period of time after installation during which a facility, or its component parts, meets or exceeds the performance requirements.

Serviceability: The ability of a structure to be serving or capable of serving its intended purposes to the uses' satisfaction.

7. REFERENCES

- Hanley C, Matos J, Kelliher D and Pakrashi V. (2017). Integrating multivariate techniques in bridge management systems. *Journal of Structural Integrity and Maintenance*, 2(3), 143-151.
- Hanley C, Frangopol DM, Kelliher D and Pakrashi V. (2017). Variations in Reliability with Bridge Live Load Definitions. *Proceedings of the ICE, Bridge Engineering*, 2(3), 143-151.
- Mahboob, Q. and Zio, E. eds., 2018. Handbook of RAMS in Railway Systems: Theory and Practice. CRC Press.
- Quirk L, Matos J, Murphy J and Pakrashi V. (2018). Visual Inspection and Bridge Management. *Journal of Structure and Infrastructure Engineering*, 14(3), 320-332.
- Reichert, P., Schuwirth, N., & Langhans, S. (2013). Constructing, Evaluating and Visualizing Value and Utility Functions for Decision Support. *Environmental Modelling and Software*, 46, 283–291. <http://doi.org/10.1016/j.envsoft.2013.01.017>
- Rijkswaterstaat, 2012. Leidraad RAMS—sturen op prestaties van systemen (in Dutch), Den Haag: Ministerie van Verkeer en Waterstaat.
- VSS, 2018. *Swiss code VSS 640900a (in. prep)*, Zurich: Association of Swiss Road and Traffic Engineers.
- Weninger-Vycudil A, Hanley C, Deix S, O'Connor A and Pakrashi V. (2015). Cross-Asset Management for Road Infrastructure Networks. *Proceedings of the Institution of Engineers – Transport*, 168(5), 442-456
- Znidaric A, Pakrashi V, O' Connor A and O' Brien E. (2011). A Review of Road Structure Data in Six European Countries. *Proceedings of the ICE, Journal of Urban Design and Planning*, 164(4), 225-232.

APPENDIX A

FACT SHEETS - CROATIA

Highway bridges operated by AZM (Highway Zagreb-Macelj Ltd.)
PhD Zvonimir Dekovic ME, Highway Zagreb-Macelj, Engineer

1. Context/Background of the contribution

Highway Zagreb-Macelj Ltd for construction, management and maintenance of A2 highway Zagreb-Macelj. Highway Zagreb-Macelj Ltd is a concession society which got the concession in 2004 from Republic of Croatia to construct, manage and maintain A2 highway Zagreb-Macelj for a period of 28 years until 2032. Highway Zagreb-Macelj is a part of Pyhrn motorway route. Highway, which has a Croatian designation A2, is classified into European road routes under E-59 designation which connects northern and middle European parts with its south-eastern part. Highway is stretching from Jankomir junction (city of Zagreb detour) to junction Trakoscan (Slovenian border, border crossing Macelj). Length of highway is almost 60 km (59.2 km).

2. Description of bridge stock/assets

There is a total of 16 bridges on highway A2 Zagreb-Macelj. 1 bridge is made of steel, while 15 are reinforced (precast reinforced concrete girders) concrete bridges. Total number of viaducts on highway A2 is 9 and they are all made of reinforced concrete. From this 9, 7 are made of precast reinforced concrete girders and 2 are made of cast in place reinforced concrete girders. There are 4 overpasses and 2 underpasses which are all made of reinforced concrete (precast reinforced concrete girders). There are 5 overpasses going over highway which are all reinforced concrete (precast reinforced concrete).

3. Bridge Management Processes and Related Standardization

All processes and actions of management and maintenance are implemented according to currently valid regulation of Republic of Croatia. Regular and special/out of ordinary inspections are performed on highway A2 Zagreb-Macelj, which is prescribed in currently valid regulation of Republic of Croatia. Regular inspection of objects on highways include: seasonal inspections, yearly inspections and main inspections which are performed every 6 years. Special/out of ordinary inspections are performed regarding out of ordinary events such as: natural hazards, severe traffic accidents, fire, explosion, landslides etc. Seasonal and yearly inspections are performed by an outsourced company contracted from concession company for immediate management and maintenance of highway. Main inspections of objects is organized and performed by concession company Highway Zagreb-Macelj Ltd and specialist companies are engaged for performance of main inspection of bridges. Objective of main inspection is to determine general condition of a structure in a sense of its bearing capacity, traffic safety, needs and terms of durability and scheduling of time intervals when certain maintenance works need to be performed and assessment of costs for individual objects. The basis for main inspection is design documentation, documentation from construction period, documentation about maintenance and operation. The result of main inspection is report about condition assessment of parts of structure, overall structure condition assessment, safety assessment and structure functionality until the next main inspection. Based on results of main inspection recommendations for regular and out of ordinary maintenance are made, as well as scheduling of time intervals when maintenance and repair works on a certain objects will be performed. In the analysis of management and maintenance of objects i.e., management of a highway, beside parameters of safety and functionality costs of managing and maintaining objects on highway are also involved which upgrades decision making process in highway management system.

Generally, regular maintenance of objects consider cleaning and maintenance, while out of ordinary maintenance considers repair or reconstruction of parts or the whole object for which it is necessary to produce technical documentation. Technical documentation for these works is produced by specialist companies outsourced by Concession company Highway Zagreb-Macelj Ltd.

4. Key lessons and challenges around Bridge Management

Unavoidable and most important factor for advancement of the existing management system is continuous professional improvement of experts/workforce who immediately perform inspections of objects as well as employees of the owner. Implementation of new technologies of continuous monitoring of parts of objects or the whole objects, which would be connected to the central system of management of highways in centre for maintenance and traffic control, would present one of technological breakthroughs for upgrading the existing object management system.

5. Conclusions, recommendations and commentary related to COST TU1406 WG5

The basis for planning of good quality and timely maintenance activities are informations about current condition of highway infrastructure collected through main inspection of objects. As a result assessment of maintenance costs per individual objects can be performed which presents a foundation of efficient and economical strategy of a highway or highway objects maintenance. For a successful and efficient management of highway infrastructure which considers objects on the highway the following is essential:

- good quality maintenance of highway infrastructure based on transfer of data and knowledge from design documentation and periods of construction to period of management and operation of highway;
- continuous professional improvement of employees;
- continuous follow-up of newest technological achievements;
- exchange of experience and informations with other concessionaires in Republic of Croatia and Europe.

Once again it is needed to emphasise the importance of continuous professional improvement of all individuals/employees included in all processes of management and maintenance of highways. As an addition to this we would like to highlight the necessity of strengthening links between companies who manage highways and science, first of all from fields of civil engineering, traffic and economy through joined projects, workshops, seminars etc.

CROATIA

Road bridges operated by CR (HC Hrvatske ceste-CR Croatian roads)
Sandra Skaric Palic M Eng CE, Infra Plan Consulting, Senior Advisor

1. Context/Background of the contribution

Croatian roads Ltd (Hrvatske ceste d.o.o.), Vovcicina 3, Zagreb, Limited liability company for the management, construction and maintenance of state roads.

Total length off road network under jurisdiction is 7.129,62 km (Official newspaper of republic of Croatia, NN103/2017).

2. Description of bridge stock/assets

Total number of bridges: total of 1756 bridges is recorded, of which 1017 are bridges with one or more spans length equal to or larger than 5 m. Type of bridge/structure: Most common type is reinforced concrete girder bridges simply supported or continuous, with one or more spans equal to or larger then 5m. Bridges classified according to static system:

- Girder bridges: 87%
- Arch bridges: 9%
- Frame bridges: 2%
- Movable bridges: <1%
- Other types of bridges: <2%

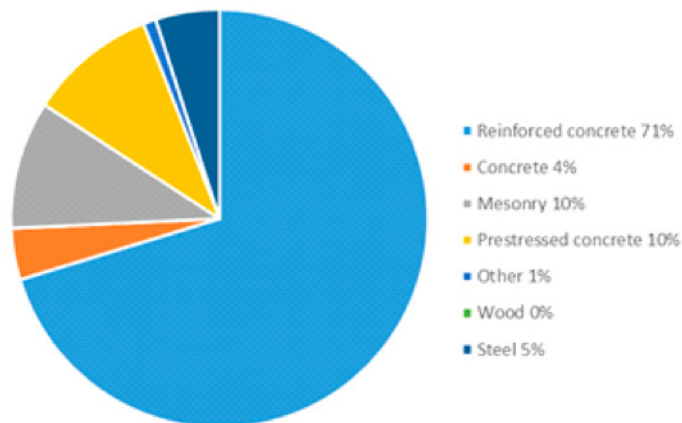

Figure A1. Croatian bridges classified as per construction material

3. Bridge Management Processes and Related Standardization

Inspections are performed through standardized procedure called HRMOS, which has been developing in CR since 1995 based upon system used by Danish direction for roads, to ensure objectivity and uniformness. Methodology used for condition assessment of bridges has six scales (0 means no damage to 5 meaning severe damage):

- 0 – bridge or element has no damages
- 1 and 2 – imperfections derived from deficient construction processes
- 3 – elements with active degradation processes
- 4 and 5 – elements with advanced degradation processes.

During general inspection 13 standard elements of bridges are graded. Bridge is assigned with the overall rating based upon these grades.

Original HRMOS software package included a module for assessment of maintenance costs of bridges but it was never used and put in practice.

Croatian Roads own human resources are mainly included in the system. Yearly inspections of bridges are conducted by engineers who also conduct Seasonal inspections, which is why they are well informed about the general condition of the road network they are managing. Yearly inspections are performed from available areas on the bridge and near vicinity of the bridge, and they generally include visual inspection of bridge elements. Engineers use 'Catalogue of defects of bridge elements' to enable uniformness of results of condition assessment procedure. Also other instructions and forms for inputs and inspections of bridges are available.

Main inspection of bridges includes special measurements and testing. In general, when these inspections are performed it is necessary to inspect all parts of structure and often use of special equipment for inspection is needed (special vehicles, revision wheels, scaffold etc.). Decisions about bridge maintenance; in a sense of restoration of structure back in its designed condition or reconstruction of bridges which means performing works which interfere with essential requirements of the structure (especially mechanical resistance and stability); are made after scheduled yearly and main inspections or based upon objective circumstances after out of ordinary events.

The first decision is about conducting specialist inspection of the bridge through investigation works (in-situ and laboratory) which can include additional testing of bearing capacity and serviceability (eg HRN U.M1.046. Norm for Bridge testing with trial load). The second decision, decision about repair design, is based upon the data set of results of specialist inspection.

Bridge Management System HRMOS has been methodologically in use since 1996. Data base about bridges is regularly updated. All legally binding inspections are performed in the time frames regulated by law:

- Regular inspections – within road patrol
- Seasonal inspection – 2x a year
- Yearly inspection – 1x-2x/2 years
- Main inspection – 1x/5-6 years
- Special/out of ordinary – as needed

The following documents are used for ensuring uniform data and standardization of visual inspections:

- Instructions for engineers for inspection of bridges
- Catalogue of defects of bridge elements
- HRMOS Manual – Volume 2: List
- HRMOS Manual – Volume 3: General overview
- HRMOS – form for inspection and input of a new bridge with layout for drawing of structure with damages
- Electronically adapted forms for field work.

4. Key lessons and challenges around Bridge Management

It is necessary to continuously work on the procedures for visual inspection of structures for advancement of uniformness of condition assessment of bridges, which is performed in scope of preparation of plans for indispensable maintenance. It is reasonable to suggest organisation of workshops for engineers who perform visual inspection of bridges, with a thorough preparation through inspection manual. Education of engineers for inspection of bridges should go in direction of deeper understanding of deterioration processes, as well as their consequences effecting traffic safety on state roads. Education of engineers for inspection of bridges should be directed to wider understanding of problem of defects, so they would be able to recognize indications which refer to certain degradation mechanisms even before external visual manifestations occur.

5. Conclusions, recommendations and commentary related to COST TU1406 WG5

Current incapability to predict condition of elements, regarding their durability and mechanisms of degradation, can be eliminated through advanced research scientific knowledge and application of mathematical statistical models.

According to some scientific research, if it is possible to combine statistical parameters with empirical data in the analysis, then a good model for planning maintenance of bridges is the one that uses homogenous Markov processes. Most often used Markov chain model worldwide is in favour if main inspections are performed regularly and if there is a long series of observed conditions. It is possible to use Markov chains in development of model for strategic maintenance planning despite the fact that we do not currently possess the necessary knowledge of how long bridges stay in a certain condition level and that condition assessments include some uncertainties. Necessary precondition for use of these models is that future main inspections of bridges are performed in regular time intervals by trained expert engineers. Model can be linked to different management strategies through calculation of repair costs of elements expressed in unit prices per bridge area (€/m²).

Regarding recognition of mechanisms which cause degradation of bridge elements in a more advanced model using Markov chain, physical-chemical models of deterioration can be used for assessment of time periods in which elements stay in certain condition before passing into the next. Scientific research should be focused on consolidation and analysis of data about processes regarding durability on our bridges and processing of data into bridge condition grades. Findings should be linked with condition assessment determined by visual inspection. After that estimations about time in which a certain element is staying in a certain condition can be corrected. The term condition of a bridge can then be linked to typical repairs (application of maintenance cost in Croatian roads software HRMOS is then enabled).

We suggest including other elements (average yearly daily traffic, owner and user costs, importance of a bridge in road network, detour possibilities, influence on the environment in a case of hazard etc.) in analysis of management strategies and thus upgrade decision process in bridge managements system. Also, continuous work is needed in inclusion of civil engineer, traffic and IT specialist experts and scientists from scientific area of construction, especially regarding analysis of physical-chemical properties of construction materials.

CROATIA

Highway bridges operated by HAC (Croatian Motorways Ltd)

Sandra Skaric Palic M Eng CE, Infra Plan Consulting, Senior Advisor

Stjepko Devald M Eng CE, Croatian Motorways, Main engineer, Design unit for maintenance, Construction department

1. Context/Background of the contribution

Croatian Motorways Ltd (Hrvatske autoceste d.o.o.), a limited liability company for operation, construction and maintenance of motorways, was registered and started its business activity on April 11, 2001, by splitting a single road administration. The company is 100% owned by the Republic of Croatia. Today the company runs more than 925,8 km of completed motorways with more than 1.150 structures (overpasses, underpasses, viaducts, road crossings, animal crossings), tunnels in a total length of over 35 km with some of them more than 5 km long.

2. Description of bridge stock/assets

Croatian Motorways Ltd. Owns a Structures Management System called SGG which is used for bridges, tunnels, pavements, drainage systems. Regarding part of the SGG which is used for managing bridges, the system has 1213 bridges listed. From this 1213 bridges, 1061 bridge are rated (which means that one or more inspections were done in a certain period of time and condition assessment was performed) and the system contains data (general data and condition data) about these bridges. 152 bridges are not yet inspected and are just listed in the system without any data about them. From the 1061 bridges in the system 861 are girder, 9 arch and 191 frame bridges. More than half of all bridges are over 50,0 m long.

3. Bridge Management Processes and Related Standardization

Generally SGG contains the following modules:

1. Technical data – all general data available about each bridge from original design (including uploaded drawings) and the derived state - User can print 'Bridge booklet' for each bridge which contains: ID and location, general data (type, geometry, design and construction, loads, equipment...), detailed data about the structure in general and all elements
2. Condition data – data from each inspection is in the data base including photograph of damages, quantity and location of each damage. Bridges are graded conditions 1-5: 1-very good, 2-good, 3-satisfactory, 4-bad, 5-very bad. Bridges are inspected as follows: Main inspection (visual) every 6 years, Yearly inspection- every 2 years, Seasonally – 2 times a year, Regular inspection - patrolling.
3. Algorithms for calculating condition rating based on damage data from inspection
4. Repair costs which are linked to condition data and can produce repair scenarios

Structures Management Systems contains the following file repository with instructions which can be printed for education of companies and individuals performing inspections (there is no standardization in the process and all manuals and instructions are used as agencies directions which are regulated by individual contracts with companies performing inspections/condition assessments):

- 'Definitions for keeping records in SGG – structure bridge – all types of bridges and how the record general and detailed data – 152 pages
- Damages catalogue' – structure bridges – detailed description with photos of all types of damages which can be found on a bridge – 57 pages
- 'Implementation manual for inspections in SGG' – types and periods of inspections, expertise and responsibilities regarding individuals performing inspections, documentation – 87 pages
- Planning of structures management – contains algorithms for planning priorities for maintenance
- 'Manual for condition assessment of bridges' – what and how to rate based on inspection data – 60 pages
- 'Manual for repair and renewal of bridges' – list of repair actions with costs – 15 pages

In reality SGG is used only partly, mainly as a data base with technical and condition data about each bridge. Repair scenarios in the system are never used and priority ranking for maintenance is not made based upon the system. The process of bridge management is performed as follows:

- Main inspections are performed by companies hired by the agency. People who do the inspections are not required to have any formal training or experience for this (engineers and technicians perform these inspections).
- Regular inspections (patrols) are performed by agencies employees.
- Patrols are circulating all parts of the highway managed by the agency (including bridges) daily.
- Patrols inform about any damage they notice especially if it effects traffic safety.
- After the information about damage from the patrols is received and recorded, SGG is checked for information about the structure. Previous inspections on the bridge and rating based upon recorded damages are compared with the new data reported by patrols.
- Investigation works and repair design are contracted by HAC from outside the agency based upon new recorded data by patrols and SGG.
- Due to lack of budget objects are repaired mainly when their condition becomes critical.

4. Key lessons and challenges around Bridge Management

Main problems with the management system and the overall process highlighted in the agency, as well as improvement opportunities are as follows:

1. Due to the fact that individuals (employed by companies outsourced by the agency for inspecting bridges) who perform inspections are not required to have any formal training or experience, data that is collected from these inspections is not consistent and is highly subjective. This is the reason why often ratings about bridges in the system is different from the actual condition of

the structure. Because of this agency states the importance of introduction of education and training of external companies and inspectors performing inspection of bridges. This would ensure consolidation of data quality which is entered in the SGG system. Generation of condition assessment and the final rating of bridges would become reliable once the data is valid. The System would become completely functional then and could be used for priority ranking.

2. Agency also highlights the importance of education of agencies employees who perform inspections yearly and seasonally.
3. Perform continuous data base updating with control of already entered data.

INDIA

1. Statistical Dispersion of assets:

Indian Bridge Management System was initiated by Ministry Of Road, Transport and Highways from July 2015. Inventory of assets started from December 2015 and was virtually completed by October 2016. Subsequently two cycles of bridge inspections were conducted.

Type of bridge

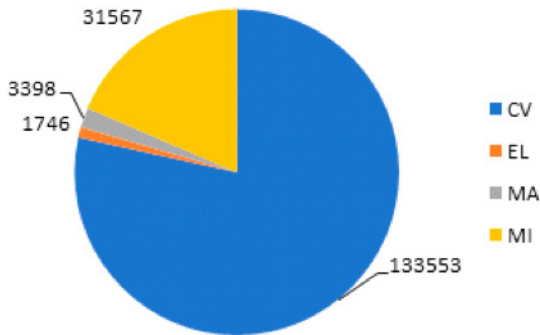

Figure A2. Indian Bridges Classified as per type.

The data presented is as of database of 1st November 2017. The dispersion of bridge assets on National Highways of India is as under for various parameters.

TYPES OF STRUCTURE IN INDIAN HIGHWAYS			
No.	Length of Structure	Nomenclature used	Number of Bridges
1	L < 6 meters	Culverts (CV)	133553
2	6 < L < 60meters	Minor Bridge (MI)	31567
3	60 < L < 150 Meters	Major Bridge (MA)	3398
4	L > 150 meters	Extra- long bridge (EL)	1746

Table A1. Overall Structures in Indian Highways

S.No	Age of Bridge	Number of bridges
1	Below 1 year	327
2	01 years to 04 years	4392
3	05 years to 09 years	8032
4	10 years to 14 years	7602
5	15 years to 24 years	7266
6	25 years to 49 years	7429
7	50 years to 74 years	1505
8	75 years to 99 years	135
9	100 years & above	23

Table A2. Bridges as Per Age

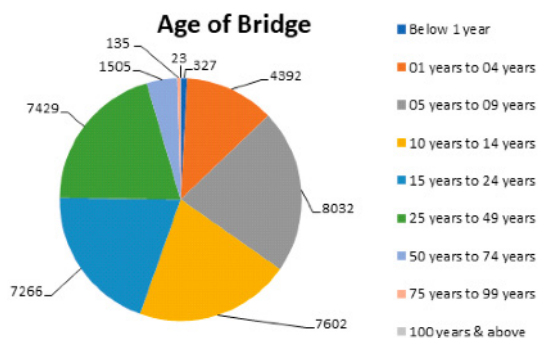

Figure A3. Indian Bridges Classified as per age.

S.No	Type of Crossing	Number of bridges
1	All railway crossing where no bridge exists	16
2	Bridge crossing over canal bodies, nalla, drains and other bodies	26233
3	Bridge crossing over ocean, sea and creek bridges.	71
4	Bridge crossing over river.	4050
5	Bridge over Railway lines and railway related structure (ROB)	1064
6	Bridge over road and highway	569
7	Grade separators, Flyovers	539
8	Rail under bridge (RUB)	82
9	Tunnels	21
10	Underpass	4066

Table A3. Bridges as per Crossing Feature

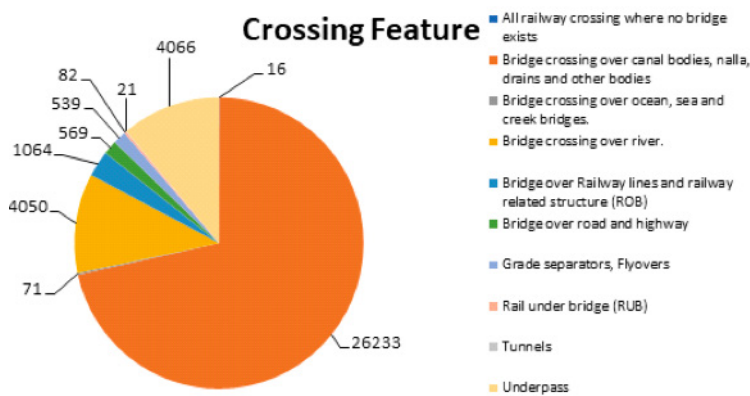

Figure A4. Indian Bridges Classified as per crossing feature.

S.No	Material of Construction	No of Bridges
1	Aluminium, Wrought Iron, or Cast Iron	12
2	Concrete	30431
3	Masonry	2566
4	Modified concrete	197
5	Other	476
6	Prestressed concrete *	2170
7	Prestressed concrete continuous *	48
8	Steel	761
9	Steel continuous	16
10	Wood or Timber	34

Table A4. Distribution of bridges as per material of construction

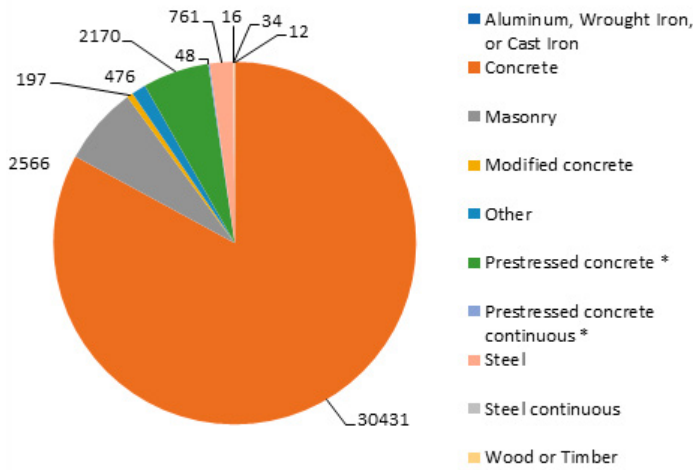

Figure A5. Indian Bridges Classified as per material of construction

S.No	Number of Lanes	Number of Bridges
1	No proper lane marking	3000
2	Number of lanes 1	1186
3	Number of lanes 2	23453
4	Number of lanes 3	4850
5	Number of lanes 4	3328
6	Numbers of lanes 6	774
7	Number of lanes 8	68
8	Number of lanes 10	43
9	Number of lanes more than 10	2

Table A5. Distribution of bridges as per number of lanes

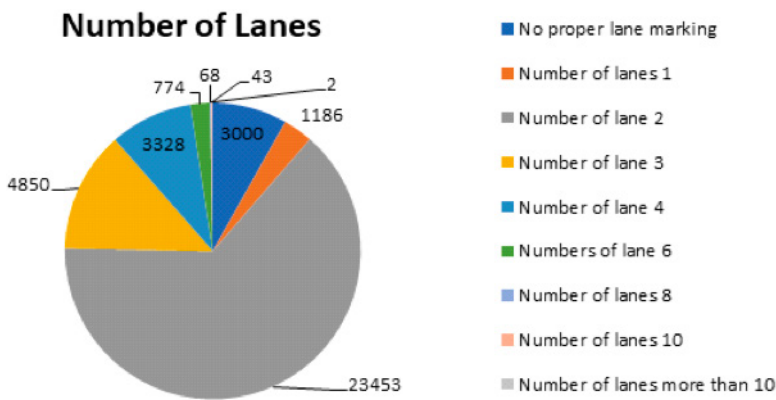

Figure A6. Indian Bridges Classified as per number of lanes

RATING SYSTEM

1. Rating nomenclature:

The codes given for rating vary from 0 to 9 and depend on the condition of the allied components. 9 signify excellent condition and is generally given only if the structure is less than one year old and 0 signifies poor condition a condition which indicates virtual closure of bridge.

Rating	Brief description
9	Excellent condition
8	Very good condition
7	Good Condition
6	Satisfactory condition
5	Fair condition
4	Poor condition
3	Serious condition
2	Critical condition
1	Imminent failure
0	Failed condition

These rating is used to assign ratings for three basic parameters:

- A. The Bridge Structural Rating Number
- B. The Bridge Functional Rating Number
- C. The Bridge Socio- Economic Rating Number.

Rating are assigned by the Field Engineer when he does the inventory of the bridge and it depicts the basic first impression of the engineer about the bridge. This rating numbers are later used for definition of all other management decision making protocol of the system.

Validation of Ratings:

In the first task, inventory data and rating is completed, the same is required to be validated during the inspection stage.

The second task during Bridge Inspection, the Bridge Inspection Engineer has to ascertain the ratings provided during inventory. This provides for in built validation of data collected during inventory. Based on the observations of the bridge parameters and the environment and traffic condition existing at bridge location, it is essential for the bridge Inspection engineer to reassess the rating provided by the Inventory engineer. This procedure fulfils the need for self-validation of all data that ensures that data used by IBMS in processing is correct and validated.

The third task during the inspection process is to complete the prognosis of distress in bridge if any distress is observed. To be able to do this, it is critical that the Bridge Inspection Engineer to understand the various deterioration processes and what type of distress causes this deterioration process to happen.

The Distress in bridge is any situation; that is not designed and has occurred. Deterioration is the manifestation or propagation of this distress in a continuous manner to cause alarm. Bridge Inspection Engineer based on his expertise and knowledge will judge the reason for the distress to have occurred and this form the prognosis of distress. The main cause of distress which sometimes results in manifestation of other type of distress or is severe is called the primary cause of distress.

The subsequent distress that gets manifested or resultant due to primary distress is called secondary distress. Distress can occur in specific and localized manner as much as it can occur in the overall structure. The final distress map of the bridge may be a result of multiple causes (primary cause and secondary cause) and combined effect of both primary and secondary causes. This could at times make it difficult to determine the correct primary cause. Primary cause can be defined as the cause that is seen to the maximum and has resulted in most extensive distress from among the all the other causes.

Ideally it is better to eliminate the causes rather than identify the cause. This could result in a matrix of causes. From among these identified causes, the primary cause can be confirmed if not properly identified initially.

Based on the cause the following parameters need to be assigned a rating. This assignment is based on the various symptoms observed and for which a rating scale of 0 to 9 is used. 0 rating is assigned for very severe condition and 9 is assigned to no distress condition.

Flow Chart for Flow of information and decision making in IBMS:

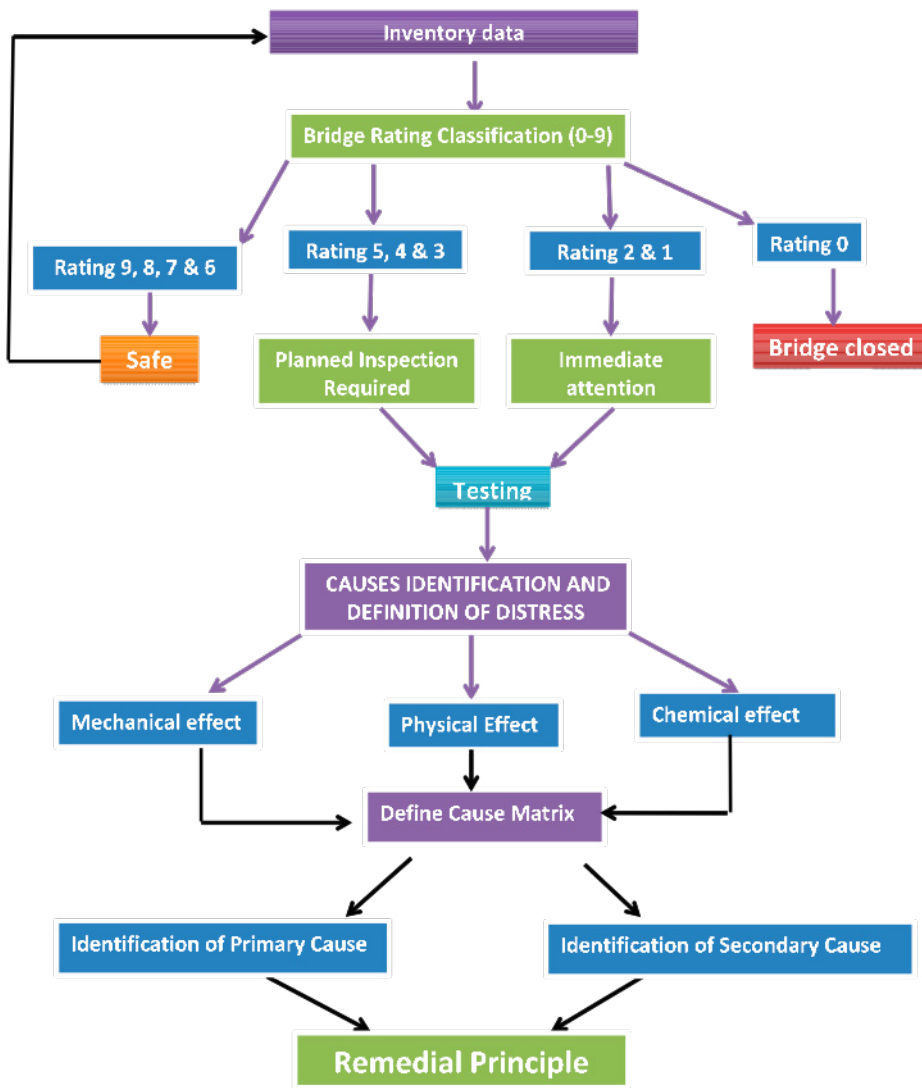

Figure A7. Flow of Information in IBMS

APPENDIX B

Paper Presented in TU1406 by CEN TC 350 in Riga Meeting

SUSTAINABILITY ASSESSMENT OF CIVIL ENGINEERING WORKS

Antonio Burgueño

FCC Construcción, S.A. Avenida Camino de Santiago, 40. 28050 Madrid. Spain.

Abstract. Large infrastructures have been pushed into the background when handling sustainability in construction due, on the one hand, to the fact that focus was made on building because of its immediate social perception and the effects its space concentration entails and, on the other hand, to the fact that for infrastructure projects there is an already systematised and quite generalised apparently alternative tool called Environmental Impact Assessment. Nevertheless, on the one hand, in all these procedures social and economic aspects are usually left aside, and, on the other, indicators and tools have not been defined for the assessment of sustainable performance of said infrastructures during their full life cycle. Several tools on the market are appearing, and it is time to standardize such tools in order to be sure we are talking about the same issue when we talk about sustainability and talk in a common language. Therefore it is convenient to develop a global and integrating criteria in order to understand how infrastructures behave within the sustainability arena, for the purposes of communicating this behaviour to the users and providing reference to the progress accomplished in the improvement of behaviour.

Keywords: sustainability, assessment, indicators, information modules, performance, life cycle.

1. Introduction.

When handling sustainability in construction, large infrastructures have always been pushed into the background due to: on the one hand, experts have focused on buildings because the social aspects perception is more immediate and because the effects of the built environment have important implications in concentrated areas; on the other hand, infrastructure projects must include Environmental Impact Assessment as a systematised assessment tool, which has been reinforced and supplemented by the recent Plan and Programme Assessment, or integrated environmental assessment.

Nevertheless, in all these tools social and economic aspects have always been left aside, and indicators and tools have not been defined for the assessment of infrastructure sustainable performance during their whole life cycle.

Therefore it was necessary to develop a global tool, integrating all these aspects in order to understand how infrastructures behave within the sustainable criteria, and to communicate their performance to users.

There is an increasing demand, in both private and public sectors, to understand sustainable construction practices, because their implementation improves the environmental, economic and social aspects.

In response to the high interest of the different stakeholders involved in the construction process, such as policy makers, investors, owners, promoters, contractors, manufacturers of products, operators, Non-Governmental Organizations or citizens, there is a widespread commitment to the principles of sustainable development.

Regarding the construction sector, most of the work undertaken at European and international level was related with buildings. The civil engineering works needs standardised methods for the assessment of the sustainability aspects of new and existing construction works and for standards for the environmental product declaration of construction products. This task is being developed from Europe through CEN Committees, and from ISO simultaneously. The work mainly consists in developing a methodology for the assessment process, starting from a general framework for sustainability in construction works, and establishing the appropriate framework for the development of sustainability indicators.

2. Standardization on sustainability in Civil Engineering Works.

The standardization of the sustainability assessment in Civil Engineering Works is being developed by two different committees with the same aim: CEN TC 350 (and within it, WG6 – Sustainability in Civil Engineering Works) and ISO TC59/SC17 (from its WG5). Subcommittee ISO/TC 59/SC 17 acknowledged at its 5th plenary meeting held on October, 2007 that there was a need for new work to be initiated within the SC focusing on the sustainability of civil engineering works. As a result of this, a new working group "ISO/TC 59/SC 17/WG 5 - Sustainability in buildings and civil engineering works - Civil engineering works" was formed. Four years later, in 2011, the european committee "CEN/TC 350 - Sustainability of construction works" decided to create also a new WG on civil engineering works (CEN/TC 350/WG 6) with the aim to include civil engineering works in CEN/TC 350 work programme, which was mainly focused on buildings.

The objective is, first of all, to provide a framework containing requirements and guidelines for the selection and development of sustainability indicators for civil engineering works, including a core set of indicators, which provide measures to express the effect which a civil engineering works has on achieving the sustainability and sustainable development.

Once defined such framework, the aim is to develop a Standard that provides a general framework for improving the methods for assessing the sustainable performance (environmental performance, social performance and economic performance) of new or existing civil engineering works during their design, production, construction, use, maintenance and end of life phases.

In CEN, the current work program is the one appearing in **Figure B1**.

Framework level	EN 15643-1 Sustainability of buildings – Part 1: general framework (TG)			Technical Characteristics	Functionality
	EN 15643-2 Assessment of buildings – Part 2: framework for the assessment of environmental performance (WG1)	EN 15643-3 Assessment of buildings – Part 3: framework for the assessment of social performance (WG5)	EN 15643-4 Assessment of buildings – Part 4: framework for the assessment of economic performance (WG4)		
Works level	PrEN 15643-5 Assessment of building and Civil Engineering Works – Part 5: Framework on specific principles and requirement for civil engineering works (WG6)				
	EN 15978 Assessment of environmental performance of buildings – Calculation method (WG1)	EN 16309 Assessment of social performance of buildings – Calculation methodology (WG5)	EN 16627 Assessment of economic performance of buildings – Calculation Method (WG4)		
Product level	WI00350028 ASustainability of construction works – Sustainability assessment civil engineering works – Calculation methods (WG6)				
	EN 15804 Environmental Product Declarations – Core rules for product category of construction products (WG3)	(See Note Below)	(See Note Below)		
	EN 15942 Environmental Product Declarations – Communication format – Business (WG3)	Note At present, technical information related to some aspects of social and economic performance are included under the provision of EN 15304 to form part of the EPD.			
	CEN/TR 15941 Environmental Product Declarations – Methodology for selection and use of generic data (WG3)				

Figure B1. Work program of CEN/TC 350

3. Developing indicators.

The civil engineering and construction sector needs sustainability indicators for its own decision-making within design, production and management, as well as for showing the economic, environmental or social impact of products and processes to the public and to clients.

In response to the high interest of the different stakeholders involved in the construction process and the large number of demands related to sustainability indicators, there is a widespread commitment to the principles of sustainable development.

Many organisations, including the United Nations, standards institutions, labour unions, national and regional governments, local authorities, financial organisation's and public interest groups, have proposed sets of indicators, but reflecting their needs and perceptions. Some of these indicators sets measure whole-society sustainability issues, others are used to measure an organisation's performance, but they are not sector-specific and don't always apply to the construction sector.

Indicators for civil engineering works should provide the means to measure the sustainability of an infrastructure, by comparing either the performance achieved with the intended performance or the performance of different construction works. To achieve this, it is important to collect indicators which are specific to the civil engineering work sector and specify which indicators can be used in the different infrastructure typologies.

Indicators are observed or calculated parameters that show the presence or state of a condition or trend. They are the tools for measuring and monitoring progress towards goals, providing a basis for judging the extent to which progress has been made, or corrective action is required. They are also an important management tool for communicating ideas, thoughts and values. Taking this into consideration, the selected set of indicators for civil engineering works should enable the different users to:

- Understand sustainability issues.
- Measure and verify the sustainability performance of an infrastructure during its different phases.
- Compare the sustainability performance of different infrastructures.
- Check if an infrastructure achieves its objectives and targets.
- Support decisions and solve conflicts.
- Involve stakeholders and demonstrate transparency to them.

These indicators have to be studied and selected in order to adapt them for their use in the methodologies developed, taking into account each specific civil engineering work typology and even each project, because of their high heterogeneity, as well as the intended users and use of the indicators.

Due to its aid to drawing up specific terms and needs of the different infrastructures types, in ISO it has been defined that there should be developed sustainability indicators for the following different typologies of infrastructures:

- industrial process infrastructures;
- linear infrastructures (including above and below ground);
- dams and other fluvial works;
- maritime works;
- public spaces.

The work is currently being done on defining indicators, but there are so far some categories considered in social, environmental and economic pillar of sustainability which still may change. They are, at the moment:

Environmental indicators categories:

- water use (quality, quantity, regulation);
- energy use;
- resource use (renewable and non-renewable, toxic substances);
- waste generation;
- pollution/emissions to air;
- pollution/emissions to soil;
- pollution/emissions to water;
- noise and vibration;
- landscape (impacts such as habitat fragmentation, created values and cultural heritage, visual intrusion, recreation);
- biodiversity (impacts such as barrier effects, mortality, disturbance, invasive species, loss of biotopes);
- resilience including adaptation to climate change.

Social indicators categories:

- accessibility;
- adaptability;
- health and comfort;
- loadings on the surroundings; (including pedestrian and traffic disturbance);
- noise and vibration;
- safety / security, (including resilience against accidental actions (fire, explosion) climate change and natural occurrences such as earthquake and flooding, etc.).
- sourcing of materials and services;
- stakeholder involvement;
- job creation;
- spatial planning (including changes in population distribution);
- protection of cultural heritage.

Economic indicators categories:

- Non construction costs
- Life cycle cost
- Construction
- Maintenance
- Operation
- Occupancy
- End of life
- Income
- Externalities

4. Sustainability assessment of civil engineering works.

The sustainability assessment quantifies aspects and impacts to assess the environmental, social and economic performance of civil engineering works using quantifiable indicators measured without value judgements. The purpose of the standardization is to enable comparability of the results of assessments, but not to set benchmarks or levels of performance.

The sustainability assessment of civil engineering works uses different types of information. The results of a sustainability assessment of a civil engineering works provide information on the different types of indicators, the related civil engineering works scenarios, and the life cycle stages included in the assessment. It will allow the sustainability assessment, i.e. the assessment of environmental, social and economic performance of a civil engineering works, to be made concurrently and on an equal footing, on the basis of the technical characteristics and functionality of the object of assessment.

In carrying out assessments, scenarios and a functional equivalence are determined at the civil engineering works level. Assessment at the civil engineering works level means that the descriptive model of the works with the major technical and functional requirements has been defined in the client's brief or in the regulations.

Assessments can be undertaken either for the whole civil engineering works, for a part of the civil engineering works or for a combination of several civil engineering works.

In concept, the integrated civil engineering works performance incorporates environmental, social and economic performance as well as the technical and functional performance, and these are intrinsically related to each other.

The user's utilization impacts and aspect are part of the assessment, including those related to the possible ways of use of the infrastructure, the user's utilization, and the way of capitalizing from the investment (e.g. the fuel consumed by the cars users of a road).

It is advisable to carry out an assessment at the earliest opportunity during the conceptual stages of a construction or refurbishment project such as in the initial planning stage in order to provide a broad estimate of the environmental performance, social performance and economic performance. As the project evolves, the assessment may be periodically reviewed and updated to support decision-making. A final assessment (as-built) should be carried out. The results of this final assessment can be used to inform all parties concerned, and also serve as the database for future new similar projects.

The information is provided in several modules, as shown in **Figure B2**.

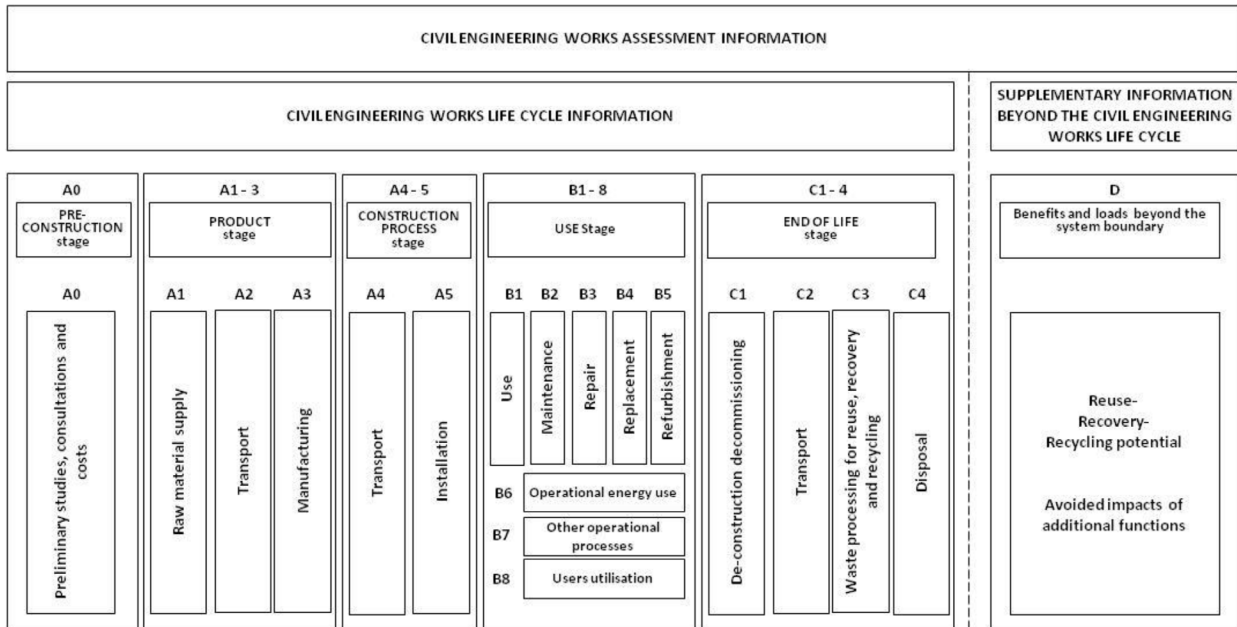

Figure B2. Information modules applied in the assessment of environmental, social and economic performance of a civil engineering works

The assessment of the sustainable performance of a civil engineering works requires information on the environmental, social and economic aspects and impacts for all information modules and it is established on the basis of specified scenarios that represent the civil engineering works life cycle. The applied scenarios are described or referenced in the assessment report and made available for communication. The scenarios must be realistic and representative and in accordance with the technical and functional requirements as given in the functional equivalence.

Information relating to the object of assessment and the functional and technical requirements is taken from the client's brief, the regulatory requirements and from the project specification. In order to achieve compatible assessments between environmental, social and economic performance of a civil engineering works, equivalent quantities and specifications for the assembly of products, and equivalent scenarios are used.

5. Conclusions.

1. There is a need of sustainability indicators for civil engineering works, and CEN and ISO committees are working on such task.
2. Assessing the economic, environmental or social impact of products and processes is an urgent demand from the Society, and a lot of work still needs to be developed.
3. As far as COST Action TU 1406 is currently working on a guideline on the quality control of bridges, and there are some developments on the topics of performance indicators, goals and definition of a quality control framework there is an opportunity of sharing knowledge and work with ISO/TC 59/SC 17/WG5 and with CEN TC350/WG6 in the task of developing indicators for the different modules they are working on at present

CONTACT DETAILS

Chair

Prof. José C. Matos
University of Minho, Portugal
chair@tu1406.eu

Vice Chair

Prof. Joan R. Casas
Technical University of Catalonia
BarcelonaTech, Spain
vicechair@tu1406.eu

Technical Secretariat

Prof. Eleni Chatzi
ETH Zurich, Switzerland
tecsec@tu1406.eu

Science Officer

Dr. Mickael Pero
COST Office, Belgium
mickael.pero@cost.eu

Website

www.tu1406.eu