

# A 'SQUARE TO ROUND' SHAPE MADE USING METAL BASED RAPID PROTOTYPING

**Dr. A. F. Ribeiro, Lic.Informática, BSc, PhD.**

Departamento de Electrónica Industrial, Univ. do Minho, Guimarães, Portugal.  
e-mail: fernando@dei.uminho.pt

**Prof. J. Norrish, BSc, MSc.**

Welding Group - SIMS Dept., Cranfield University, Bedford, UK.  
e-mail: John\_Norrish@uow.edu.au

## ABSTRACT

**In the last 18 months a new Rapid Prototyping process involving direct deposition of metal has been under development at Cranfield University. The process entails the use of a Gas Metal Arc fusion welding robot which deposits successive layers of metal in such way that it forms a 3D solid component. A solid model is first drawn using a CAD system, then data indicating the kind of layers and dimension is incorporated and the solid is automatically sliced. This slicing routine also generates reports on the welding time and conditions for the production of the component and automatically generates the robot program. Depending on the complexity of the component the time from drawing the component to being ready to press the robot start button to make the component can take less than two hours. An example of a component which was generated to test the system is described here in order to illustrate how the process is operated, the quality of the component, and the productivity which may be expected.**

## 1. INTRODUCTION

The current process was first described by Ribeiro in [1] and therefore only a brief description of the process will be given here:

To reduce prototyping time, it has often been stated that there was a need to automate the production of 'one off' components for development and evaluation. Casting, which may be used for components of this type is an expensive and time consuming process especially if used to make only ONE component. Most of the rapid prototyping processes evolved in response to this requirement use resin based materials which are not always suitable for testing purposes. Metal based prototypes are often required and additional processing is necessary to convert resin based materials to a useful form.

In the process used here the component is formed by melting and depositing the metal using the GMA welding process. A CAD drawing system is used to create the initial solid shape and a welding robot is used to manipulate the welding torch.

After having drawn the component in a CAD, a slicing 'add-on' of the CAD program is implemented to produce the desired layers which will form the robot program. It is also necessary to enter additional data to indicate the bead

geometry and the material used. Calibration of the robot is also necessary to indicate where exactly the component is going to be built in relation to the robot. The welding parameters are automatically generated by the program in order to achieve the required bead geometry and stable operating parameters. These parameters were derived from welding studies carried out by Norrish [2] and parametric equations generated by Ogunbiyi and Norrish [3]. The robot program is automatically generated and can be simulated with the use of a robot simulation program to check for collisions or other problems such as access. The robot program may be modified if necessary then compiled and downloaded to the robot.

## 2. COMPONENT SHAPE

The test component described in this paper consisted of rectangular pyramid which blends into a cylinder. This shape was generated to prove that a transition from a relatively complex square to round shape could be achieved. Figure 1 shows the original shaded CAD model of the component.

Most of the shapes known to have been produced by this technique in the past were only cylindrical shapes with no complex changes of shape and these were manually programmed. In the present case manual programming would have been complex and

time consuming and the design of the test piece was specifically chosen to illustrate the advantages of automating the programming task.

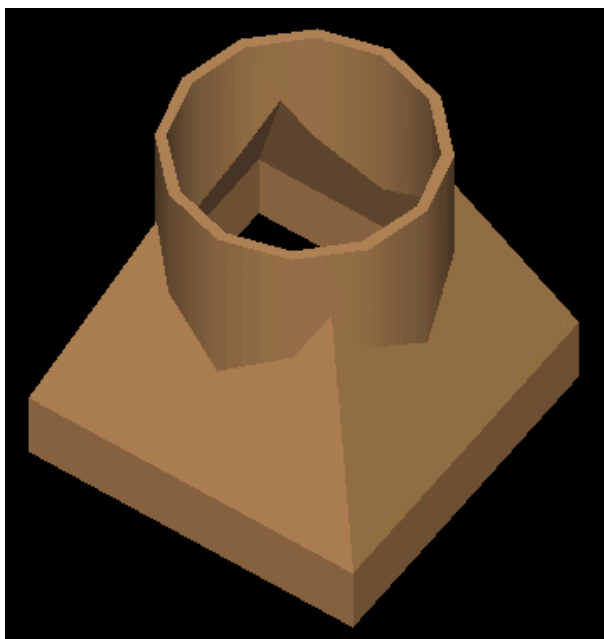

Figure 1 - Component shape to be built

### 3. COMPUTER TASKS DESCRIPTION

To build a component several computational tasks have to be performed in a certain order and these are described below.

#### 3.1 Drawing the component

The first task is to draw a three dimensional solid model of the component. In this example AutoCAD was used because it is one of the standard packages available in the market. The drawing process used Constructive Solid Geometry (CSG); a technique that uses logical instructions like *Union*, *Subtraction* and *Intersection* to make up the solid. Two parallel squares (one inside the other) were drawn, extruded and subtracted for the base part. For the middle area a similar technique was used but the extruded squares were tapered. In the upper area (cylindrical) two cylinders were drawn and subtracted. The middle and top area were then 'union'ited. This drawing task took about 15 minutes to perform. (An expert CAD user would be expected to complete this simple task in less time). The outline dimensions of the solid are 200 mm high and the base is a square of 190 mm by 190 mm.

#### 3.2 Data Input to the Slicing add-on

The next phase of the process is to input the data for the slicing of the solid.

The location of the work table on which the component is going to be built is read from the robot. The robot is moved to an index position (centre of the table) and the co-ordinates are read together with the orientation of the torch. (This task can take up to five minutes). The bead geometry of each welding layer (height and width) is also input to the slicing routine. The weight of the metal used per metre is also input in order to calculate some values such as weight of the full component. After the bead geometry is input the welding parameters are automatically generated.

#### 3.3 Slicing routine

When the slicing routine is invoked it starts slicing the solid object. If the object cannot be sliced in one step (due to shape constraints) it will be sliced in more than one part. For each part of the component, there will be a different robot program and consequent change of position of the component if necessary. For the shape shown in Figure 1 the slicing routine was carried out in one step with one only robot program. The slicing routine applied to the shape shown in Figure 1 resulted in the shape shown in Figure 2.

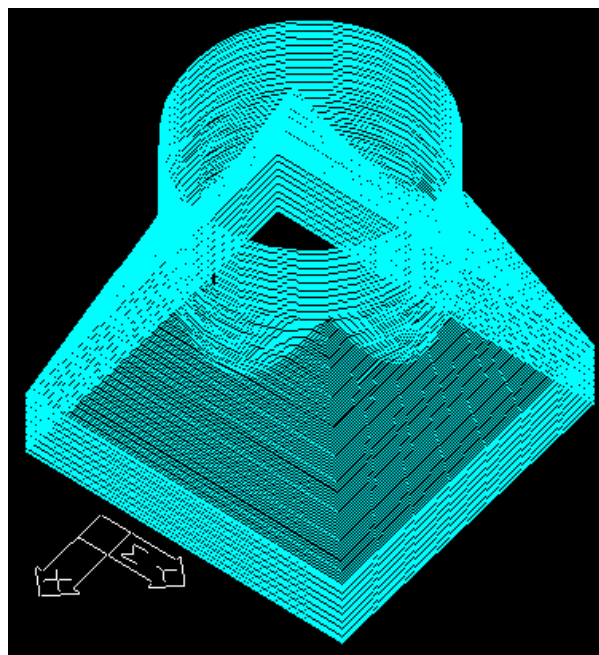

Figure 2 - Slices Generated for this shape

The blue lines are the automatically generated slices and these represent the path that the robot has to follow to build this component. All these lines are parallel to the base because in this case this was the orientation used for the slicing but any orientation may be used according to the desired shape.

The time taken to generate all these slices was about 3 minutes on a Personal Computer with an Intel 80486 microprocessor, mathematical co-processor and with 8 Mbytes of RAM. It should be noted that AutoCAD needs a relatively large amount of free Hard Disk space for use with swap files.

### 3.4 Outputs of the Slicing routine

Once, the slices are generated it is possible to produce some additional outputs from the slicing software.

The first output is an Individual Report describing the build up plan for the component. (This report is used by the welding technician and it includes all the welding parameters as well as a table with one line of instructions per layer. Each line contains the layer number, the height values for that layer, the welding length and the time it will take to complete the layer. The welding technician can set up the welding parameters to those described in the report before starting welding also be able to monitor (during welding) which layer is actually being built and how long it will take until the end of the component.

The second output, is a Global Report which describes for each part of the component (a component can be made in several parts with different robot programs) all the relevant parameters. Some of the more important are the name of that part, the bead dimensions, the torch orientation used, the number of layers, the weld length, the weight, time to make and the wire length necessary for that part.

All these slices can be saved to a different file in a DXF file format which can be later on read by a robot simulation package to check for collisions and reachability. These lines can also be used to program the robot path.

If the user prefers a more simple way to program the robot, instead of using a robot simulation package he can just use the option given by this routine to generate automatically the robot program. This robot program is generated in ARLA Language which is the language of the ASEA family robots. So far, this routine only generates ARLA language but other robot languages could be implemented and that task doesn't take very long to execute. The advantages of using the robot simulation program is that all the checks can be made during the simulation while if the user prefers to generate automatically the robot program it takes not more than a few seconds.

### 3.5 Robot Program

The robot program generated is a TEXT file and the robot does not understand TEXT files which means that that code has to be compiled. The compiler used was SPORT which is a program made by a Swedish company that works only with ASEA robots only. Another alternative was OLP3 (Off-Line Programming 3.0) from ABB Robotics. Any of these programs can be used and

they do almost exactly the same things except SPORT works in a Windows environment and OLP3 works under DOS environment.

After having compiled the program the binary file is downloaded to the robot. This is carried out via a RS232C serial cable which links the personal computer and the robot. Once again, either SPORT or OLP3 can be used for this task.

The time it took to compile the robot program was about 30 seconds and the time to download it to the robot was about 1 minute, using SPORT software. It is important to note that up until now all the tasks were performed on a computer and did not involve the use of the robot.

## 4. SOFTWARE/HARDWARE

The software used was AutoCAD release 12 for DOS as the CAD system, the Slicing Routine was created by the author of this paper and the Off-Line program to compile and download the robot program was SPORT 1.0.

As far as the hardware is concerned the computer used was a PC Personal Computer with an Intel 80846 microprocessor with a speed of 66 MHz clock with 8 Mbytes of Memory RAM. The robot used was an IRb 2000 from ABB robotics.

The use of this particular Hardware/Software is not mandatory. Any suitable Personal Computer could be used. A possible limitation is the **Slicing** program which was developed to work with AutoCAD, but this could be translated to any other language and CAD system. The robot used is not a limitation. In fact this robot was not even fitted with the normal welding robot options. Any other robot could be used if the robot program was generated in the desired language.

## 5. TRIAL DESCRIPTION

A sketch showing the dimensions of the test component is shown in Figure 3. In this trial, all the values are in mm unless otherwise stated.

After the welding parameters chosen, the layer geometry was 1.4 mm height and 6.5 mm width. As a result 144 layers were deposited, 29 for the base (the square section) and 115 for the rest.

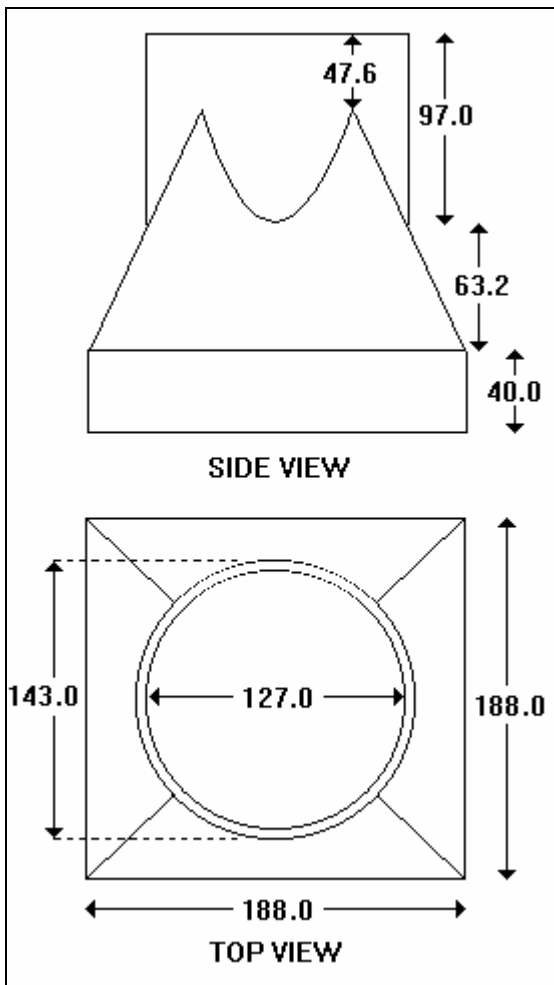

Figure 3 - Side and top view of the shape with dimensions in millimetres

The base plate used to deposit the layers was made of stainless steel and its weight was 7.960 Kg.

Table 1 shows the estimated values, the actual values and the difference between them for weld length, wire length, weight and time.

	Estimated	Actual	Error	Dimen.
weld	80.889	80.889		metres
wire	1060.00	Unknown		metres
weight	6.984	7.020	0.036	Kg
time	2:44:10	2:44:27	00:17	h:m:s

Table 1 - Comparison of estimated/real values

Notes:

- The wire length used could be measured using a wire feed speed sensor but this was not fitted in the trial.
- The weight was 7.020 Kg (assuming a Wire feed speed of 7.1 metres per minute)
- The final component (including the base) weight was 14.980 Kg.

- The time to build was 17 seconds more than the expected probably because the speed of the robot is not absolutely accurate and in almost 3 hours an error of 17 seconds is reasonable.

As far as the robot program is concerned the TEXT file was about 105 Kbytes and the compiled version was around about 34 Kbytes. Taking into consideration that the robot memory can handle programs up to 64 Kbytes, 34 Kbytes is about half the memory. The reason for this is that several small arcs and lines are produced for a better quality.

The time it took to compile this program was about 6 seconds using a PC 80486 66 MHz. The time to download to the robot was around about 1 minute using a 80386 PC at a 16 MHz clock rate. It is important to note that the serial link influences the speed with which the programme is downloaded.

It is interesting to note the extra growth of 4 mm in the first 10 layers. This can be explained by the temperature of the base plate (cold) before starting welding compared to the temperature after a few layers. Therefore the first few layers are higher and thinner which creates an extra height. Another important aspect is that in the corners, the component grows at a greater rate in this area. This can be explained by the short stop that the robot makes when travelling from one point to another. This stop is very short but can be noticed with this geometry.

The welding conditions were very stable and this is the most important aspect in the build up of any component with this process. The process was also virtually spatter free which implies a better surface finish.

## 6. COMPONENT DIMENSIONS ASSESSEMENT

The component was examined to check the quality of the final product and deviation from the planned shape. A dial gauge was used to measure the dimensions of the final component as described in Figure 4.

The following tables show the measured values from the component at different locations.

	Measured	Planned	Deviation
F82	187.5	188.0	-0.5
F24	188.0	188.0	0.0
F46	187.2	188.0	-0.8
F68	187.6	188.0	-0.4

Table 2 - Outside dimension on Bottom

	Measured	Planned	Deviation
G1	8.2	8.0	0.2

G2	8.2	8.0	0.2
G3	8.0	8.0	0.0
G4	8.0	8.0	0.0
G5	8.2	8.0	0.2
G6	8.2	8.0	0.2
G7	8.3	8.0	0.3
G8	7.9	8.0	-0.1

Table 3 - Thickness on Top (cylinder)

	Measured	Planned	Deviation
E15	124.7	127.0	-2.3
E26	124.8	127.0	-2.2
E37	125.2	127.0	-1.8
E48	125.6	127.0	-1.4

Table 4 - Inside dimension on Top

	Measured	Planned	Deviation
D15	141.5	143.0	-1.5
D26	141.0	143.0	-2.0
D37	141.2	143.0	-1.8
D48	141.2	143.0	-1.8

Table 5 - Outside dimension on Top

	Measured	Planned	Deviation
A1	97.2	97.0	0.2
AA2	47.7	47.6	0.1
A3	98.2	97.0	1.2
AA4	48.3	47.6	0.7
A5	98.2	97.0	1.2
AA6	48.3	47.6	0.6
A7	96.6	97.0	-0.4
AA8	47.2	47.6	-0.4

Table 6 - Height of the cylinder

	Measured	Planned	Deviation
ABC1	197.2	200.0	-2.8
ABC 2	196.1	200.0	-3.9
ABC 3	199.4	200.0	-0.6
ABC 4	197.7	200.0	-2.3
ABC 5	196.1	200.0	-3.9
ABC 6	195.5	200.0	-4.5
ABC 7	195.5	200.0	-4.5
ABC 8	195.5	200.0	-4.5

Table 7 - Total Height of the component

In each table, the first column shows the actual values measured from the component, the second column shows the expected value and the third column shows the difference between them or in other words the error.

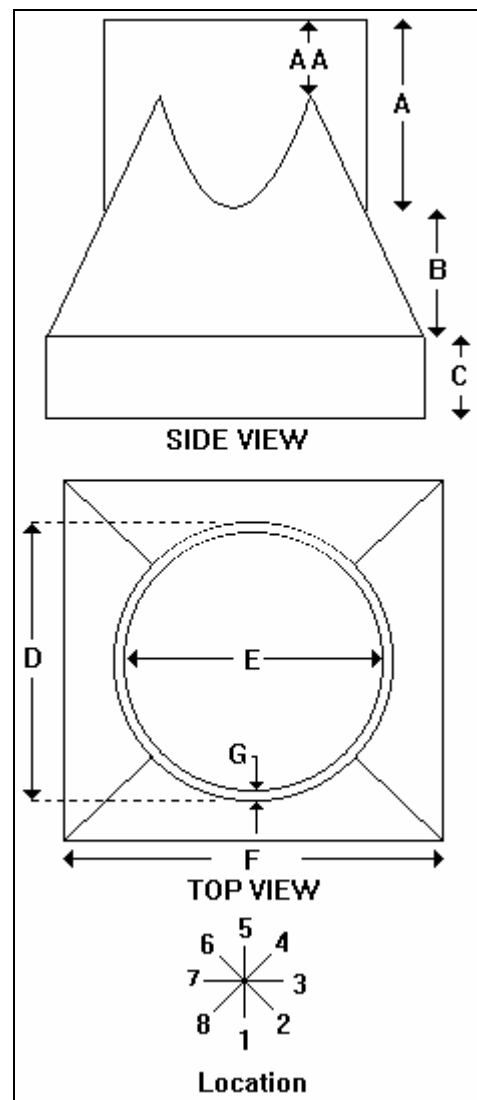

Figure 4 - Component nomenclature

Table 2 shows the dimensions of the length of the bottom of the component. The error is once again very small and therefore acceptable. In this case the error is always negative because the measurements were taken from the base of the component and the first few layers were higher and thinner than the expected because the base plate was cold. The thinner layers account for the negative error.

Table 3 shows the thickness of the component. This was not measured over the complete component because of the difficulty in reaching the middle and bottom areas. But by the values taken from the top area it can be seen that the thickness is very constant. The maximum error is 0.3 millimetres and in most cases the thickness is larger than that expected which assures a minimum limit.

Table 4 and Table 5 show the internal and external diameter of the cylinder in the top (circular) area. These values are lower than the expected giving an error of about 2 mm on average. This deviation is formed over the complete circumference which means that the component is acceptably concentric.

The error indicates the shrinkage of the cylinder in this region.

Table 6 shows the height of the cylinder measured from the top. Once again, the values are acceptable having a maximum error of 1.2 mm. The largest errors occur in the middle of the edges of the square. The error originated at the corners are smaller. Probably because the layer catch up in the corners.

In Table 7 the height of the whole component is analysed. In the total height of the component, there is a 4.5 mm loss. This may have occurred because of incorrect welding parameters or errors in bead geometry estimation. With refinement of welding parameters this could almost certainly be corrected.

In average the errors shown here are very small which makes the process very acceptable in terms of accuracy and the repeatability of the dimensions would be expected to be excellent.

## 7. CONCLUSIONS

The dimensional accuracy achieved depends very much on the shape of the component. The more complex it becomes the more difficult it is to estimate.

Bead geometry estimation is obviously extremely important. If the geometry is not estimated accurately it can influence the overall component shape. In this practical trial, the height of the component was most seriously affected. The stand off, contact tip to workpiece separation, was not constant. It needed some adjustment during the building process. This affects the process deposition rate. The tapered shape of the component was one of the reasons for the stand off variation. If a tapered section is to be built, the distance between two layers is still the same but the real distance is a little increased because of the angle, this effect could be corrected by on-line torch height adaptive control.

The top cylinder is about 0.2 mm out of concentricity which is very acceptable for a component with this size.

Usually, a welding system tends to loose quality after a certain time, which means that the process should be stopped from time to time. This would also allow the welder to change the contact tip which tends to wear out and change the average wire tip position.

The main advantages of the slicing program used was that the slices were automatically created, the ARLA robot program was generated completely automatically and it was not essential to use a

robot simulation package to test it, although simulation can be used to save on line time.

## 8. ACKNOWLEDGEMENTS

Mr. Ribeiro would like to thank John Norrish for his support in this project and his expertise in the welding field and also Dr. McMaster for his academic help. My very special thanks go to John Savill for his strong support in welding all of the components. A special thank you for my wife is also deserved for her understanding during the difficult periods of this project. My Portuguese sponsor JNICT also deserves a big thank you.



Figure 5 - Picture of the Component produced using this process

## REFERENCES

- [1] RIBEIRO, A. F. M., NORRISH, J. AND MCMASTER R., *Practical case of Rapid Prototyping using Gas Metal Arc Welding*, 5th International Conference on Computer Technology in Welding, Paris, France, 15-16 June 1994.
- [2] Norrish, J., *Advanced Welding Processes*, Institute of Physics Publishing, 1992.
- [3] NORRISH, J., Ogunbiyi B., *An Adaptive Quality Control concept for robotic GMA Welding*, 5th International Conference on Computer Technology in Welding, Paris, France, 15-16 June 1994.