

Life-Cycle Analysis of Buildings

Environmental impact of
building elements



Coordination:
Luís Bragança
Ricardo Mateus

Life-cycle analysis of buildings

Environmental impact of building elements

Luís Bragança and Ricardo Mateus

September 2012

IMPRINT

Coordinators: Luís Bragança e Ricardo Mateus
Title: Life-cycle analysis of buildings – environmental impact of building elements
Cover work: Fátima Castro

ISBN: 978-989-96543-3-4

Printed in Portugal by iiSBE Portugal

1st Edition, September 2012

500 copies

Legal deposit: 333258/11

This document is protected by the current legislation of copyright. A partial copy of this document should be preceded by an authorization request (in writing) to the authors.

© Luís Bragança and Ricardo Mateus

ACKNOWLEDGMENTS

The coordinators of this publication would like to express their appreciation for the institutional contribution that was given by the Physics and Technology of Construction Laboratory of University of Minho and by all those that individually, in a more exhaustive or punctual way, contributed to the development of this work, in particular:

Luciana Mota, Research Fellow
Daniel Pinheiro da Silva, LFTC-UM
Catherine Araujo, LFTC-UM
José Amarílio Barbosa, LFTC-UM
Fatima Castro, Research Fellow
Daniel Granja Oliveira, Finalist Student of the Degree in Civil Engineering
Filipa Andrade, Finalist Student of the Master in Civil Engineering
Marlene Nogueira, Finalist Student of the Master in Civil Engineering
Michael Silva Nunes, Finalist Student of the Master in Civil Engineering
Pedro Mações Ferreira, Finalist Student of the Master in Civil Engineering

GENERAL INDEX

LIFE-CYCLE ANALYSIS OF BUILDINGS: ENVIRONMENTAL IMPACT OF BUILDING ELEMENTS

PRESENTATION NOTES	i
ACKNOWLEDGMENTS	iii
LIST OF ACRONYMS	xi
1. INTRODUCTION	1
1.1. Application of LCA in buildings and other constructions.....	1
2. THE LIFE-CYCLE ANALYSIS METHOD (LCA)	4
2.1. Steps to perform a generic LCA.....	4
2.1.1. Objectives and scope	5
2.1.2. Life-Cycle Inventory (LCI).....	5
2.1.3 Life-cycle impact assessment.....	7
2.1.4 Interpretation of the results.....	8
2.2. LCA Variants.....	9
2.3. Developments in the use of LCA in buildings and other constructions.....	10
2.4. LCA Tools.....	12
3. ENVIRONMENTAL PRODUCT DECLARATIONS (EPDs)	13
4. LIFE-CYCLE COSTS ANALYSIS (LCC)	17
5. SYSTEMS TO SUPPORT SUSTAINABLE DESIGN AND TO RATE THE SUSTAINABILITY OF BUILDINGS	19
5.1. Objectives of the systems	19
5.2. Brief overview on existing systems.....	21
5.3. Assessment and certification of the sustainability of buildings - the particular case of the SBToolPT system	24
6. DEVELOPMENT OF THE LIFE CYCLE ANALYSIS (LCA) DATABASE	27
6.1. Objectives and Scope.....	27
6.2. Life-cycle Inventory.....	30
6.3. Quantification of the categories of environmental impact.....	30
6.3.1. Abiotic resources Depletion Potential (ADP).....	31

6.3.2. Global Warming Potential (GWP).....	31
6.3.3. Ozone depletion potential (ODP).....	31
6.3.4. Acidification Potential (AP)	31
6.3.5. Photochemical Ozone Creation Potential (POCP).....	32
6.3.6. Eutrophication Potential (EP).....	32
6.3.7. Embodied non-renewable energy (ENR).....	32
6.3.8. Embodied renewable energy (ER).....	32
6.4. Structure and utilization of the LCA database.....	33
7. FINAL REMARKS.....	35
8. REFERENCES.....	37

ANNEXES

ANNEX I – DESCRIPTION OF BUILDING ELEMENTS.....	AI.1
AI.1. Floors.....	AI.1
AI.2. Exterior walls.....	AI.5
AI.3. Interior walls.....	AI.11
AI.4. Roofs.....	AI.15
AI.5. Windows.....	AI.21
ANNEX II – LCA DATABASE.....	All.1
All.1. Floors.....	All.1
All.2. Exterior walls.....	All.7
All.3. Interior walls.....	All.15
All.4. Roofs.....	All.23
All.5. Windows.....	All.31
All.6. Construction materials.....	All.37
All.7. AVAC and hot water heating equipment.....	All.41

FIGURES INDEX

Figure 1: Stages of LCA implementation.....	6
Figure 2: Swiss organizations that joined forces to develop the Ecoinvent database and the respective competences.....	7
Figure 3: Schematic representation of the life-cycle phases included in each one of three variants of LCA analysis.....	10
Figure 4: LCA integrated with the different phases of a building's life-cycle.....	11
Figure 5: Example of an EPD of a construction product - pages 1 and 2.....	14
Figure 6: Example of an EPD of a construction product - pages 3 and 4.....	15
Figure 7: Holistic approach to assessing the sustainability of buildings.....	20
Figure 8: Dimensions and categories of the SBTool ^{PT} system.....	25
Figure 9: (a) label used to communicate the level of global sustainability through the SBTool ^{PT} system; (b) Certificate used to communicate the sustainability of a building evaluated through the SBTool ^{PT} methodology.....	26
Figure 10: Conventional phases of the life-cycle of a building and processes contemplated in the LCA database of constructive solutions.....	29
Figure 11: Figure 11: Mode as the environmental information of a constructive solution is structured in the LCA database.....	33

TABLES INDEX

Table 1: Characterization factors of the Global Warming Potential.....	8
Table 2: Indicators of sustainability for buildings.....	12
Table 3: Indicators for assessing the environmental performance.....	12
Table 4: Listing of various methodologies associated with sustainable construction, according to the project Annex 31..	22
Table 5: Environmental impact indicators considered in the database of LCA data developed.....	28
Table 6: LCA Method and units used in the quantification of each of the categories of environmental impact.....	31
Table 7: Principle to be adopted for quantifying the impacts of the life cycle of a building.....	34

LIST OF ACRONYMS

ADP – Abiotic resources Depletion Potential
AP – Acidification Potential
ASC – Sustainability Assessment of Construction
CEN – European Centre for Standardisation
CML – Centre for Environmental Sciences, Leiden University, Netherlands
ENR – Incorporated non-renewable energy
EP – Eutrophication Potential
EPD – Environmental Product Declaration
ER – Incorporated renewable energy
GWP – Global Warming Potential
IPCC – Intergovernmental Panel on Climate Change
IPP – Integrated Product Policy
ISO – International Organization for Standardization
LCA – Life-cycle analysis
LCC – Life-cycle Costs
LCI – Life-cycle Inventory
LFTC-UM – Physics and Technology of Construction Laboratory of University of Minho
LNEC – Nation Laboratory of Civil Engineering
ODP – Ozone Depletion Potential
PCR – Product Category Rules
POCP – Photochemical Ozone Creation Potential

1. INTRODUCTION

Construction is a sector which, by its nature, has high environmental impacts. Globally, the cumulative environmental impact of construction processes has increased exponentially due to the large number of urban operations in progress. Most of this impact is related to the operation and maintenance phases of a building. A recent study conducted by the North American Environment Protection Agency (EPA) shows that the construction in the United States is the third largest industry in terms of contribution to emissions of greenhouse gases.

In Portugal, most of the built environment impact in sustainable development is related to the housing sector (Mateus, 2009). At the environmental level, this sector is directly and indirectly linked to the consumption of large amounts of natural resources (energy, water, minerals, wood, etc.) and to the production of significant amounts of waste. For example, it is stated that although Portugal has a mild climate, the residential sector accounts for about 17% of the total national energy consumption (DGGE, 2005). In addition, this sector is also responsible for the consumption of considerable quantities of water, about 132l/inhabitant/day of drinking water, being a substantial part of this used in flushing cisterns (INAG, 2005).

Proper use of materials, products and construction technologies can significantly contribute to a better environmental performance of a building's life-cycle and, therefore, to its sustainability. A Life-cycle analysis (LCA) is recognized internationally as a holistic analytical technique for the assessment of environmental impacts associated with a product, system or service throughout its entire life-cycle. In most cases this method is also identified by the acronym LCEA¹, when it is aimed to differentiate the evaluation of environmental aspects from other aspects (economic and social).

The Life-cycle analysis (LCA) is a useful approach to quantify the potential environmental impacts associated to the life-cycle of a product, process or service. This assessment is essentially quantitative, since it evaluates the energy and material consumptions and the waste released into the environment. In addition, this method can be used in the evaluation and implementation of measures to improve environmental performance.

The LCA method was developed and is used for decades, but it was only standardized in the late 90s, by the International Organisation for Standardisation (ISO 14040). The LCA is oriented to the evaluation of products or materials, but its application to construction products, including the buildings, is generally accepted. Environmental performance is usually measured through a wide range of potential effects, such as: global warming potential; stratospheric ozone depletion; tropospheric ozone (smog); acidification of soil and water resources; eutrophication of water supplies; contribution for the depletion of fossil fuels; water consumption; release of toxic substances into the water, air and land.

1.1. Application of LCA in buildings and other constructions

LCA can be applied to a single product or to a set of products, such as a building. The LCA methods are applied to buildings since the early 1970s, with the aim of evaluating the energy flows. In the late 1980s some researchers developed a more rigorous and comprehensive approach for the assessment of the environmental impacts of a building during its life-cycle (Häkkinen *et al* 2002).

LCA is very important to compare several design alternatives that meet the required performance but that differ in terms of environmental impacts. For buildings, the environmental performance of construction materials, as well as the impact on landscape and biodiversity, often dominate the life-cycle of a building. The environmental impacts of the buildings' life-cycle, such as houses and offices, are mostly associated with the consumption of energy for air conditioning. It is estimated that in conventional buildings, the operation phase accounts for approximately 80% to

¹ Acronym for the expression "Life-Cycle Environmental Analysis"

94% of the total life-cycle energy consumption, while 6% to 20% is consumed in the extraction of raw materials, transportation and production, and less than 1% is consumed in the end-of-life scenarios (Berge, 2000). For this reason, in buildings, project teams should seek more energy efficient alternatives, while in other constructions such as dams and bridges, priority should be given to the eco-efficiency of materials. However, the development of energy efficient buildings and the use of less polluting energy sources will increase the importance of the construction and end-of-life stages.

The adoption of environmental LCA in buildings and other construction works is a complex and time consuming task because a building incorporates hundreds, and sometimes thousands, of individual products and, in a construction project dozens of companies might be involved. Additionally, the expected life-cycle of a building is exceptionally long, corresponding to dozens or hundreds of years. Other constraint is that, traditionally, each building or construction is unique and is designed as such, since there is little standardization in the design of buildings (Kotaji, Schuurmans & Edwards, 2003).

However, it is widely recognized in the field of Building Sustainability Assessment that LCA is a preferred method for evaluating the environmental pressure caused by the materials, construction elements and by the whole life-cycle of a building. Although there are several LCA recognized tools, this approach is not extensively used by the buildings stakeholders, including those who design, build, buy or use the buildings. Moreover, most tools for building sustainability assessment and rating are not consistent with the LCA method. In most of these tools and systems, the evaluation of environmental performance is based on the properties or attributes of certain materials, such as: recycled content, recycling potential and distances from the production site to the construction site (Carmody, Trusty, Meil *et al*, 2007). Due to its complexity, most of existing LCA-based tools and systems are used and developed only by experts, in most cases at the academic level.

To overcome this situation and to promote their practical application, the process of quantifying the environmental performance was simplified in most popular sustainability rating systems. Environmental performance quantification methods currently integrated in the sustainability certification are not consistent with the LCA method, but have played a major role in the implementation of sustainability in the building sector. The method used to quantify the environmental performance is not the same in different tools and systems, and consequently the results of an evaluation are not the same, nor comparable. Therefore it is important to use more precise methods for assessing the environmental performance, since this is the only way which allows to verify, with certainty, whether the performance predicted by the specification was actually achieved in the project. Furthermore, this solution becomes important for the interpretation of the results and comparative analysis of results obtained from the use of different certification systems (Bragança *et al*, 2008).

In order to standardize, to facilitate the interpretation and to compare results from different methods of building sustainability assessment developed within the European countries, in 2005 the European Committee for Standardisation (CEN) established the Technical Committee 350 (CEN/TC 350), under the name of "Sustainability of Construction Works ". This Technical Committee aims to develop voluntary standards for methods to assess sustainability aspects of construction works, both new and existing. Moreover, it is intended to develop the legal framework for the Environmental Product Declarations (EPD) of construction products (CEN, 2011). As result of the work done to date, the following pre-standards and standards were developed:

- CEN/TR 15941:2010, Sustainability of construction works – Environmental Product Declarations - Methodology for the selection and use of generic data;
- EN 15643-1:2010, Sustainability of construction works – Sustainability assessment of buildings - Part 1: General framework;
- EN 15643-2:2010, Sustainability of construction works – Assessment of buildings - Part 2: Guidelines for the evaluation of environmental performance;
- FprEN 15643-3, Sustainability of construction works – Assessment of buildings - Part 3: Guidelines for the evaluation of social performance;
- FprEN 15643-4, Sustainability of construction works – Assessment of buildings - Part 4: Guidelines for the evaluation of economic performance;
- prEN 15978, Sustainability of construction works – Assessment of environmental performance of buildings - Calculation method;

- FprEN 15942, Sustainability of construction works – Environmental product declarations - Communication format business-to-business;
- prEN 16309, Sustainability of construction works – Assessment of social performance of buildings - Methods.

One of the barriers to the spread use of the LCA method in construction in Portugal is related to the fact that conventional project teams do not have the necessary skills to its application. Thus, and despite recent efforts, the LCA method, as it is standardized, is not to being applied in most projects.

Based on this background, this publication aims to contribute for a more comprehensive application of the LCA method in construction, including buildings. Based on the progress of the Technical Committee 350 (CEN/TC 350) and the ongoing work in iiSBE Portugal, in the development of the Portuguese system for sustainability assessment (SBTool^{PT}), this publication will present in a streamlined approach the steps for performing a LCA of a building. Additionally, this book presents, at the end, a database with the quantification of environmental impact categories of materials and building elements that are conventionally adopted in building projects in Portugal. This database will allow supporting design teams' decision making towards the selection of materials and building elements with improved environmental performance.

In short, with this publication it is intended to promote the application of the LCA method by the conventional project teams in order to improve the environmental performance of the life-cycle of buildings and thus to contribute to a more sustainable built environment.

2. THE LIFE-CYCLE ANALYSIS METHOD (LCA)

2.1. Steps to perform a generic LCA

Life-cycle analysis (LCA) is an analytical methodology whose objective is to assess the resources content and the environmental impacts associated with the life-cycle of a manufactured product. The most important applications of LCA tools are:

- Analysis of the contribution of the various stages of the life-cycle to the global environmental impact. This application aims at setting priorities in selecting materials or products;
- Comparison between products for internal or external communication.

The LCA method is standardized, since the second half of the 90s, by the International Organisation for Standardisation (ISO 14040). Initially, many thought that the LCA could be a good tool to support the environmental qualities of a product in marketing campaigns. However, over the years it became evident that this was not the best application for the LCA (Pre-consultants, 2008). Although it is important to clearly communicate the results of a LCA, in a careful and well balanced way, these tools prove to be extremely useful for optimizing production processes of companies, from extraction of raw materials to the final product.

In recent years, the evaluation of the environmental performance of products, based on their whole life-cycle, has become a fundamental aspect for new environmental policies. A good example is the concept of IPP (Integrated Product Policy), developed and promoted by the European Commission. Additionally, in other countries, such as China and the USA, this approach has been promoted as a key aspect.

Other aspects that have catalyzed the importance of LCA tools are: the sustainability reports of companies; the assessment of the construction sustainability; and, in recent years, the development of Environmental Product Declarations (EPD's). These tools have become essential for assessing the environmental performance of companies based in the different environmental impact categories, and essential for the communication of results. According to "Fortune" magazine, most of the top 500 companies worldwide announce the sustainability of their processes (Pre-consultants, 2008).

The life-cycle analysis is based primarily on the assessment of quantitative aspects that include the materials and energy flows and has become a scientific basis for the new concepts mentioned above. In most cases, the LCA tools provide the necessary input data to internal and external arguments and to report the results. It is only possible to communicate the environmental impacts of products and production processes when knowing the LCA methodology.

Currently there are two specific rules for defining the framework and requirements of a LCA: ISO/FDIS 14040 2006, Environmental Management – Life Cycle Assessment – Principles and framework; and the ISO/FDIS 14044 2006, Environmental Management – Life Cycle Assessment – Requirements and guidelines. These standards replaced in July 1, 2006, the four standards that prevailed until then: ISO 14040, ISO 14041, ISO 14042 and ISO 14043.

According to ISO 14040 and ISO 14044, and as shown in Figure 1, the implementation of a LCA analysis is accomplished in four phases:

- Definition of Objectives and Scope;
- Life-Cycle Inventory;
- Life-Cycle Impact Assessment;
- Interpretation.

As shown in Figure 1, LCA is essentially an iterative process.

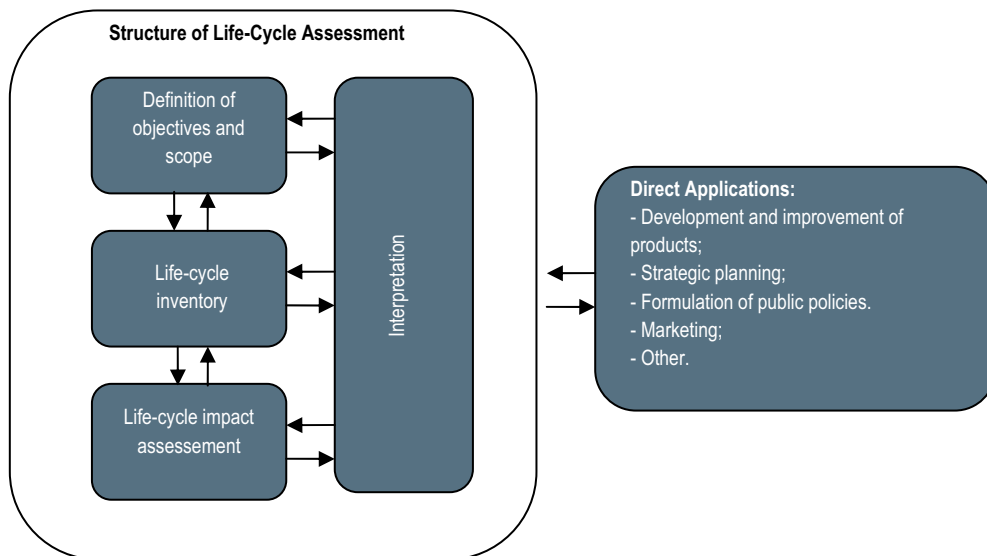

Figure 1: Stages of LCA implementation (adapted ISO/FDIS 14040: 2006)

2.1.1. Objectives and scope

As happens in all models, it is necessary to understand that a model is a simplification of reality, which means that reality is distorted in some way. The challenge for the practitioner of LCA is thus to develop models in order that the simplifications and, therefore the distortions, do not influence the results very much. In ISO 14040 it is stated that "the purpose of the life-cycle assessment must state in an unambiguously way the planned application, the reasons for carrying out the study and intended audience, i.e. to whom the results will be reported". The scope must be sufficiently well defined to ensure that the extent, depth and detail of the study are consistent and sufficient for achieving the planned objectives.

In order to achieve the above challenges, in this phase the objectives of the study are formulated and specified, according to the intended application, together with the following aspects: the target audience of the evaluation; the various stages that compose the building life-cycle and its relevance to the purpose of the study; the functional unit that will be assessed; the boundary conditions; and the methodology for the allocation of impacts and consumption of raw materials in the various processes. In defining the Objectives and Scope, the object of study is described in the form of a functional unit. When comparing, for example, a beam of reinforced concrete with a steel beam, the functional unit may be "one beam for a load of 10KN/m." Direct comparison of 1 kg of steel with 1 kg of reinforced concrete, without taking into account the amount of material required for the desired structural performance is not a proper functional unit.

2.1.2. Life-Cycle Inventory (LCI)

LCI involves collection, description and verification of data, as well as the modelling of the product system. In this phase are identified all inputs and outputs of the system. In terms of inputs are quantified, for example, the materials and energy used and, in terms of outputs, air emissions, water emissions and solid waste.

This phase is very time consuming, because it is often necessary to collect, from the producers, inventory data associated with the production system. To this end it is inevitable to develop one or more questionnaires to collect the necessary data to this stage, which is essential to perform the life-cycle analysis.

However, approximately 80% of the data that is needed for a common LCA analysis is already available, so it is not necessary to have the tedious task of collecting all the data via questionnaires (Pre-Consultants, 2008). This information can be found in databases, literature or in internet. However, it is necessary to carefully use the existing data, especially the one that comes from unknown sources or on which there is no further information, because the use of data that is not appropriate for the product and the requirements defined in the previous phase will cause large biases in the results.

One of the most accepted sources of information by the experts in LCA is the Ecoinvent database. The development and updating of this database are undertaken by the Ecoinvent Centre (also known as Swiss Centre for Life Cycle Inventories) located in Switzerland. The Ecoinvent resulted from the update and integration of information contained in other well known databases as the ETH-ESU 96 and the BUWAL250, among others (Figure 2).

The first version of Ecoinvent was launched in 2003. The latest version available (v2.0) contains life-cycle inventory data for over 4000 industrial processes, including energy supply, resource extraction, materials supply, chemicals, metals, waste management systems and transport services. Nowadays it is one of the most widely used databases in the life-cycle impacts analysis of buildings and building products in Europe.

The description of the data set which is stored in the database is described in detail in the Ecoinvent's internet page at www.ecoinvent.org. The main features of this database are:

- Covers information related to a wide range of industrial processes;
- The data are presented in two distinct ways: unit and system;
- Compatible with various types of boundary conditions and forms of allocation of impacts;
- It is well documented, because it is possible to find the context and all the considerations that underpin the inventoried values;
- Compatible with uncertainty analyses, for example, the lognormal distribution with standard deviation;
- The emissions are specified in sub-compartments. For example, one air emission is subdivided into emission in populated areas of high or low density, or to the stratosphere. Although there are currently no methods for evaluating the impacts that are compatible with this sub-compartmentalization of information, it is expected that in the future LCA methods are developed in order to have it in account;
- It is regularly updated.

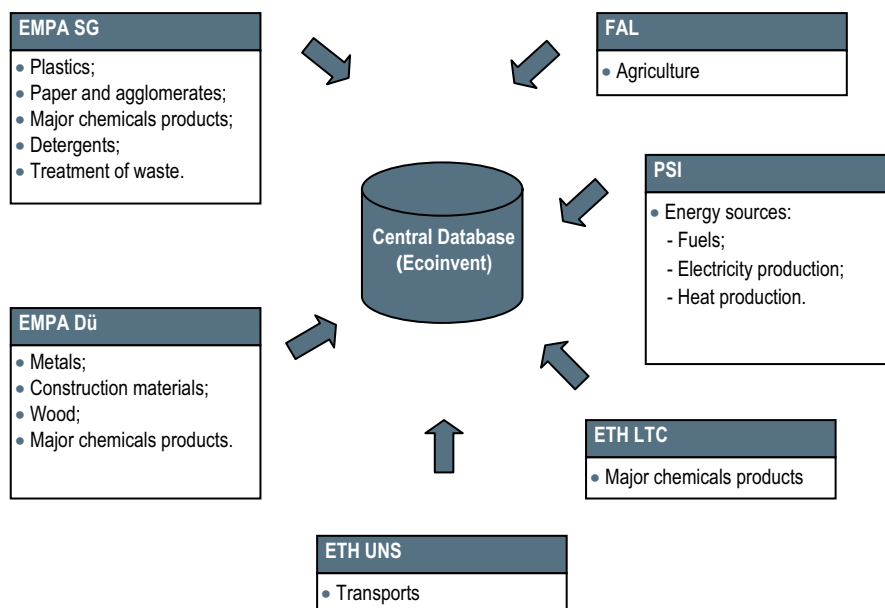

Figure 2: Swiss organizations that joined forces to develop the Ecoinvent database and the respective competences (source: www.ecoinvent.org)

2.1.3 Life-cycle impact assessment

The assessment of the environmental impact categories is defined as a technical process, quantitative and/or qualitative, to characterize and assess the effects of the flows identified in the previous phase (Bragança, Matthew & Koukkari, 2010). This phase of the LCA methodology is the systematic assessment of impacts, i.e., determining the potential contribution of the product to the environmental impact categories such as Global Warming, Acidification, among others.

According to ISO 14040, this stage is divided into two required steps (classification and characterization) and two optional (normalization and aggregation). According to the same standard, a study that does not include the steps of classification and characterization, cannot be called LCA analysis, but of life-cycle inventory (LCI).

The results of the phase inventory (LCI) usually contain hundreds of different emissions and parameters related to resource extraction. The **classification** step includes the distribution of the results in the LCI phase to different categories of impact that are relevant for the purpose of analysis. For example, emissions of CO₂ and CH₄ contribute to Global Warming so are assigned to this impact category, while emissions of SO₂ and NH₃ are attributed to the impact category Acidification. It is possible to assign certain emissions simultaneously to different impact categories. For example, the SO₂ can also be attributed to the categories Human Health and/or Respiratory Diseases.

The **characterization** phase comprises the study of the relative contribution of each LCI results in the value indicated of each environmental impact category. Although different emissions can contribute to the same category of impact, their contribution is not equal. To this end it is necessary to define the different characterization factors associated with each emission and with the different types of impact categories. For example, are shown in Table 1, the characterization factors associated with various emissions which contribute to the Global Warming Potential (GWP) according to the method LCA "BEES" (Lippiatt, 2002).

Table 1: Characterization factors of the Global Warming Potential (source: Lippiatt, 2002)

Emissions	Characterization factors - GWP _i (g equivalent to CO ₂)
Carbon Dioxide (CO ₂ , fossil)	1
Carbon tetrafluoride (CF ₄)	5700
CFC-12 (CCl ₂ F ₂)	10600
Chloroform (CHCl ₃ , HC-20)	30
Halon 1301 (CF ₃ Br)	6900
HCFC 22 (CHF ₂ Cl)	1700
Methane (CH ₄)	23
Methyl bromide (CH ₃ Br)	5
Methyl chloride (CH ₃ Cl)	16
Methylene Chloride (CH ₂ Cl ₂ , HC-130)	10
Nitrous Oxide (N ₂ O)	296
Trichloroethene	140

According to the table above, considering a time period of 100 years, the contribution of 1 gram of CH₄ to global warming is 23 times greater than the contribution of 1 gram of CO₂. In this way, and by the application of Equation 1 is possible to determine a single index, expressed as grams of carbon dioxide per functional unit of product that adds the different substances which contribute to this impact category.

$$GWP = \sum_{i=1}^n m_i \cdot GWP_i \quad [1]$$

Where m_i is the mass (in grams) obtained in inventory step for one emission i and GWP_i is the characterization factor of the Global Warming Potential associated with the emission i .

The **normalization** step enables the comparison between different types of environmental impact categories, because in this step the values of impacts are converted into the same unit. The next step, **aggregation**, allows the determination of global indicators and involves assigning a weight to each category of environmental impact, depending on their relative importance.

The methods of assessing the impact of the life-cycle comprise the analysis of the input and output of materials, of energy consumption and of emissions to the environment of a product over its life-cycle. There are basically two types of life-cycle evaluation methods: the intermediate (midpoints) and the final (endpoint). The first reflect the environmental mechanism and allow obtaining indicators for the environmental impact, while the seconds reflect the broad consequences, i.e., reflect issues of environmental concern such as human health, species extinction and the availability of resources for future generations, between others. As an example of existing intermediate methods are CML Baseline 2000, Cumulative Energy Demand, TRACI, among others. Regarding the final methods it is possible to refer Eco-Indicator 99, EPS EDIP 2000 and 2003.

Generally, the assessed number of impact categories evaluated ranges from 10 to 20. Some methods allow the aggregation of results obtained in different categories into a single overall value and others do not. The type of method used mainly depends on the objective of the study.

2.1.4 Interpretation of the results

The last stage, **Interpretation** is often considered the most important. At this stage, it is analysed the processes and materials that contribute most to the impacts of a product and are conducted sensitivity and uncertainty analyses. The main purpose of LCA should be consistent with the goal and scope of the study. Thus, given the obtained results it is possible to identify the origin of the impacts, to interpret the differences recorded, to compare solutions, to clarify limitations and to suggest recommendations. The findings of a LCA analysis are taken during this phase and this phase further comprises a review of the results by an independent expert, especially when the results of the comparisons are to be made public.

The uncertainties of the data are normally easier to handle since these uncertainties can be expressed as a range or standard deviation. There are statistical methods, such as Monte Carlo technique, which can be used to deal with this kind of uncertainty and calculate their influence on the results of LCA. In an analysis the uncertainties are related to the fact that there is a way to realize a fully adapted model of reality. In all LCA are made more or less subjective choices. The factors that most influence the uncertainties are: representativeness; allocation processes; life considered useful, end of life scenario adopted, and the functional unit considered. All these factors may have significant impacts on the results, but it is not always easy to deal with these uncertainties only through the use of Monte Carlo technique. Sometimes it is necessary to combine this technique with a sensitivity analysis. The principle of sensitivity analysis is to change the assumption and recalculate the LCA. Thus, with this type of analysis is possible to achieve a better understanding of the magnitude of the effect of iterative assumptions that are made throughout the LCA.

2.2. LCA Variants

The Life-Cycle Analysis also presents three variants, depending on the phases of the life-cycle that are studied: **cradle-to-grave**; **cradle-to-gate** and **cradle-to-cradle**.

An analysis **cradle-to-grave** includes the entire life-cycle of a product, from the extraction of raw materials ("cradle") to the deposition phase ("grave"), passing through the use phase. In an analysis **cradle-to-gate** it is only considered a part of the life-cycle of the product, the one that goes from the extraction ("cradle") to the factory gate, i.e. encompasses all processes prior to their transportation to the final consumer. The use phase and the deposition of a product are generally omitted. This type of assessment is usually based on the Environmental Product Declarations (EPD's). The analysis **cradle-to-cradle** is a variant of the analysis cradle-to-grave, in which the last stage of the life-

cycle of a product is a recycling process. In Figure 3 is shown schematically the stages of the life-cycle included in each of three variants of analysis.

The LCA methodologies address in detail the environmental dimension by evaluating the performance of the solution to the level of some categories of environmental impact, but in most cases do not address the other dimensions of sustainable development. However, there are some more complete LCA methodologies that include the economic performance in the evaluation.

2.3. Developments in the use of LCA in buildings and other constructions

The evaluation of buildings' life-cycle of and other constructions has been growing. Construction in general and in particular the buildings' sector accounts for a major portion of the contribution of environmental impacts. The development of LCA methodologies and tools has been promoting the use of more sustainable construction practices.

The LCA of buildings and other constructions comprise the ways in which built structures and facilities are purchased and installed, used and operated, maintained and repaired, modernized and rehabilitated, and finally dismantled and demolished or reused and recycled.

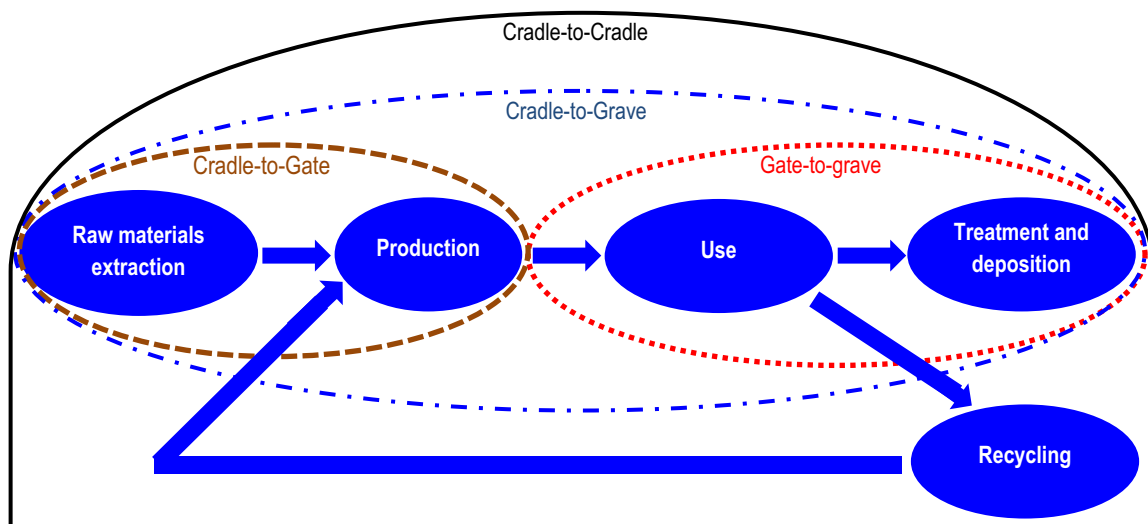

Figure 3: Schematic representation of the life-cycle phases included in each one of three variants of LCA analysis

Currently, the application of LCA method to buildings may also include the analysis of economic performance and analysis of functional performance. Figure 4 shows a LCA integrated with the phases of a building, in which it is considered the economic and social aspects, besides the environmental factors.

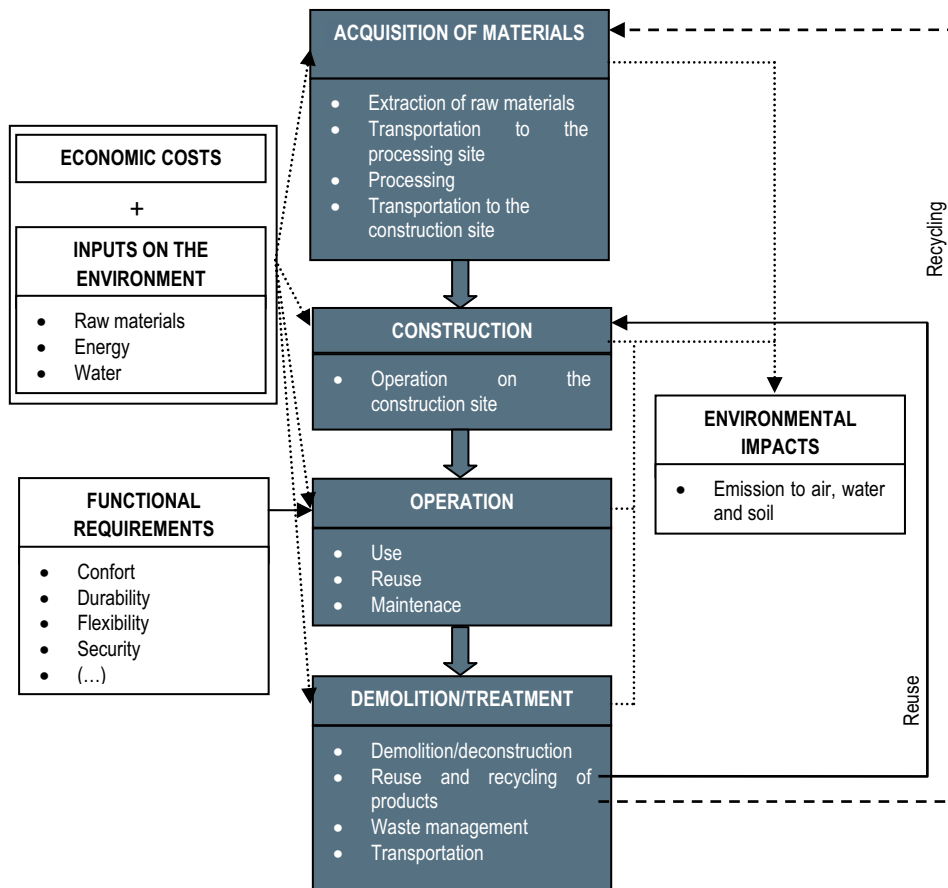

Figure 4: LCA integrated with the different phases of a building's life-cycle

For buildings, a generic LCA involves the following steps and goals (Kotaji, Schuurmans & Edwards, 2003):

1. The life cycle of the building is described. What will be included in the study will depend on the context. It may be included how the building will be constructed, operated, maintained and demolished and yet what happens to waste after demolition. These are processes which contribute to the life-cycle performance of a building, but that may not be included in all types of study;
2. The building is decomposed into construction materials and building elements. The way the different materials and building elements are defined is not necessarily relevant, what matters is that the building is fully described by the addition of different materials or building elements;
3. For each material and constructive solution, it is performed a LCA analysis to its production process (cradle-to-gate). The analysis may also include the processes of transportation to the construction site, the building process, the use, the maintenance processes, the destruction processes and the waste treatment processes for each of the materials defined in the model. In this case, the analysis would be "cradle to grave". This analysis should be performed in a consistent manner with the objectives and scope of the study.
4. Add up the results of the LCA analysis performed at each material and constructive solution, in order to obtain the LCA results for the building.

In recent years, ISO and CEN have been prominent in the development of standardization actions for assessing the sustainability of buildings.

ISO, by ISO/TC 21929-1, provides the framework and guidelines for the development and selection of appropriate sustainability indicators for buildings. This standard addresses the assessment of economic, environmental and social performance of a building. Regarding environmental indicators it is made a distinction between those that can be presented in terms of environmental loads (for example, the total CO₂ emissions), impacts (for example, the

contribution to global warming) and others that influence the amount of loads or impacts (as an example, the adaptability of a building, durability, etc.). In Table 2 are presented the environmental, economic and social indicators prescribed in ISO/TC 21929-1.

Table 2: Indicators of sustainability for buildings (source: ISO/TC 21929-1, 2006)

Environmental	Economic	Social
<ul style="list-style-type: none"> • Climate changes; • Destruction of the ozone layer; • Acidification; • Eutrophication; • Formation of photochemical oxidants; • Depletion of non-renewable resources; • Formation of pollutants. 	<ul style="list-style-type: none"> • Investment; • Use (energy, water, etc.). • Deconstruction and waste treatment; • Development of the economic value of the building; • Revenues generated by construction. 	<ul style="list-style-type: none"> • Quality of buildings; • Effects of construction related to health and safety of users; • Accessibility; • User satisfaction; • Architectural quality of buildings; • Protection of cultural heritage.

The set of rules that is currently being developed within the Technical Committee CEN/TC 350 (see section 1.1) provides a set of possible indicators for assessing the sustainability of buildings. The rules regarding the assessment of social and economic performance (FprEN 15643-3 and FprEN 15643-4) are still in a premature stage of development, so this section only presents environmental indicators defined by this Committee of standardization.

The rule prEN 15978:2011 provides the method of calculating the environmental performance covering all phases of the building life-cycle (phases of installation, operation, maintenance and end of life) and the list of environmental indicators is developed in such way that it enhances the use of LCI data obtained from environmental product declarations (EPDs). According to this rule, and as shown in Table 3, the environmental performance indicators are divided into two groups: i) environmental impacts expressed in LCA categories; ii) environmental impacts based on life-cycle inventory (LCI) data, but not expressed in LCA categories.

Table 3: Indicators for assessing the environmental performance (source prEN 15978:2011)

Environmental impacts expressed in LCA categories	Environmental impacts based on life-cycle inventory (LCI) data, but not expressed in LCA categories
<ul style="list-style-type: none"> • Depletion of abiotic resources; • Climate changes expressed as Global Warming Potential; • Destruction of the stratospheric ozone layer; • Acidification of soil and water resources; • Eutrophication; • Formation of tropospheric ozone, expressed as photochemical oxidants. 	<ul style="list-style-type: none"> • Use of non-renewable resources, in addition to the primary energy; • Reuse and use of recycled products; • Use of non-renewable primary energy; • Consumption of drinking water; • Storage of non-hazardous waste; • Storage of hazardous waste; • Nuclear waste (hazardous waste separated).

2.4. LCA Tools

In order to simplify the LCA analysis at the scale of the building, in recent years there have been developed several specific computer tools based on LCA method, such as SimaPro (Netherlands), Gabi (Germany) Eco-Quantum (Netherlands), EcoEffect (Sweden), ENVEST (UK), LISA (UK), ATHENA (Canada) and LCA House (Finland). A comparison of the various features of these and other tools can be found in several publications, such as in Forsberg and Malmborg (2004). Most of these tools are based on a bottom-up approach that is that the overall impact of a building results from the sum of the impact of each of the materials and components. Additionally, LCA tools for evaluating buildings allow the accounting of other relevant aspects for the environmental impact such as the energy consumption (Erlandsson & Borg, 2003).

3. ENVIRONMENTAL PRODUCT DECLARATIONS (EPDs)

The development of EPDs, has been an important field of application of LCA methodologies. For example, in some countries and sectors there are hundreds or even thousands of products that present the mentioned declaration. The declaration usually consists of listing the results obtained for each of the categories of environmental impact studied. The EPDs are a good source for quantifying the environmental performance of materials and products.

The EPDs are a voluntary system of description of the environmental performance of products and are a good source for quantifying the environmental performance of materials and products. This voluntary system is based on rules for the presentation of environmental characteristics. These rules, known as Product Category Rules (PCRs), vary depending on the type of product and establish the principles for assessing the environmental impact categories and other default parameters for the type of product in evaluation in accordance with the standards ISO 21930, ISO 14025 and ISO 14040.

The PCRs describe with great detail how should be made the analysis of the life cycle for the development of EPDs and comprise the listing of categories of environmental impact to be analyzed and the identification of LCA methods to be used in its assessment. One of the entities most active in the development of PCRs is the Swedish organization of EPDs. Information can be found about the work of this organization in <http://www.environdec.com>. This internet domain also describes the necessary procedures for the development of new PCRs.

The standard ISO 14025 gives general guidelines for the environmental declarations, but these guidelines are not specific enough to make EPDs as this standard is oriented for the PCRs. The CEN has developed a technical report CEN/TR 15941:2010 relative to the methodology for the selection and use of information in the development of EPDs, and also developed the norm FprEN 15942 relative to the business-to-business communication format of the EPDs.

In general, in the EPDs is possible to find information about the following environmental impact categories (PRÉ, 2008):

- Non-renewable resources (including or not the energy content);
- Renewable resources (including or not the energy content);
- Global warming (in kg equivalents of CO₂);
- Destruction of the ozone layer (in kg equivalents of CFC-11);
- Acidification (in kg equivalents of SO₂);
- Formation of photochemical oxidants (in kg equivalents of C₂H₄);
- Eutrophication (in kg equivalents of PO₄).

The environmental impact categories are defined in a similar way to the method of analysis LCA "CML", so that this method is often used in their quantification.

In general, the EPDs present the following objectives/benefits:

- Provide information about the environmental performance of a product or service;
- Stimulate the supply and demand of products or services with less environmental impact throughout the life cycle;
- Induce the improvement of the environmental profile of products from other suppliers, leading to the reduction of environmental pressure associated to the category of product or service.

In addition, EPDs could be used by designers as a support to the use of materials and building elements with lower environmental impact and as a source of information for the assessment of the sustainability of buildings and other construction works.

For example, in Figures 5 and 6 is presented the contents of an EPD corresponding to cold finished structural hollow sections. At the request of the authors it was hidden the identification of the producer of that construction product.

In an approach bottom-up, the EPDs of products and construction components can be the basis of quantification of impacts embedded in a building. As a major limitation of this approach should be noted that practically all producers in the context of construction does not possess or does not communicate the EPDs of their products. However, it is expected that in the short term, the EPDs will be mandatory. At that time it will be easier to quantify the environmental impact incorporated in a building.

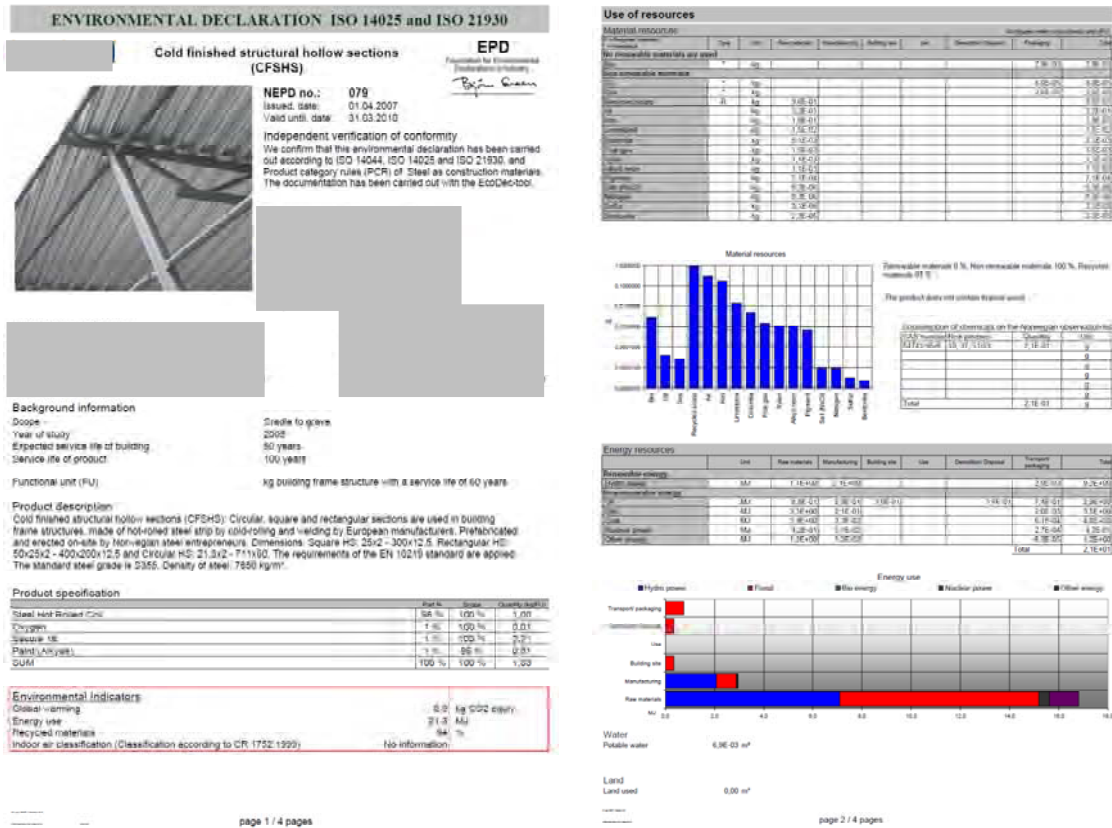

Figure 5: Example of an EPD of a construction product - pages 1 and 2 (source: Swedish organization of EPDs)

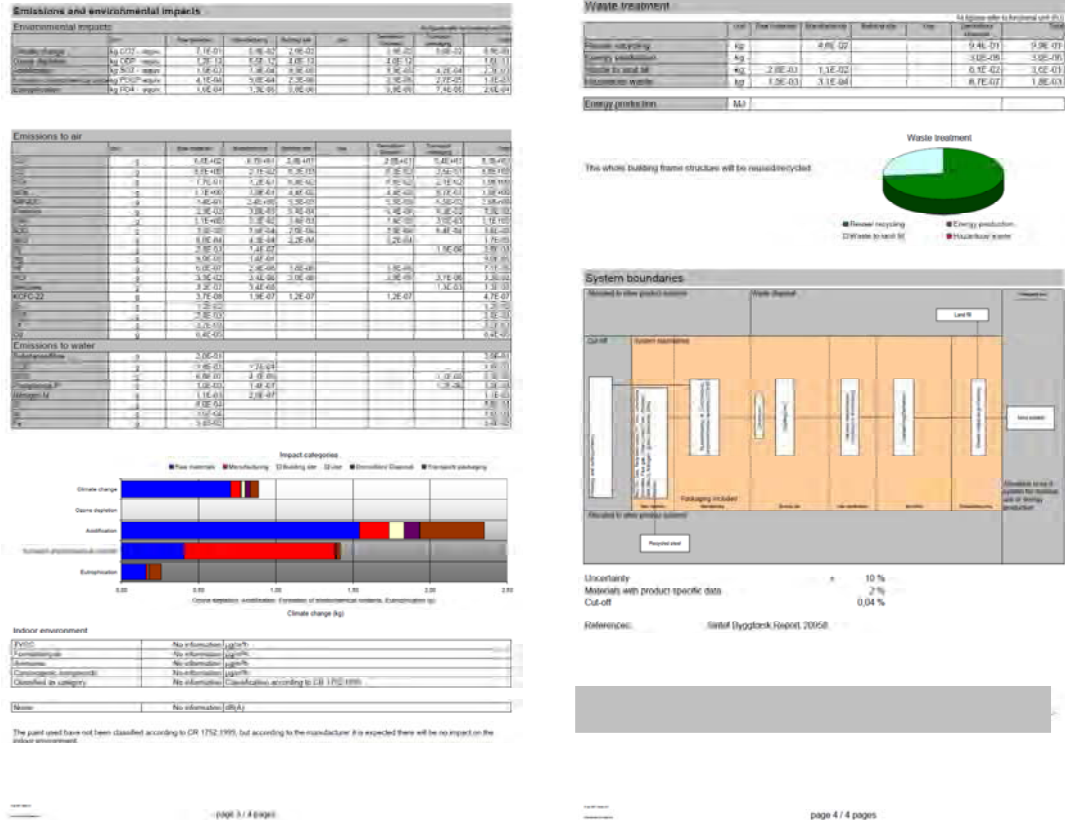

Figure 6: Example of an EPD of a construction product - pages 3 and 4 (source: Swedish organization of EPDs)

4. LIFE-CYCLE COSTS ANALYSIS (LCC)

The Assessment of Life-Cycle Costs (LCC) of a building is more directing, consensual and objective than, for example, the assessment of the environmental performance. There is currently a high quantity of LCC methodologies and it is possible to find quantitative data in several databases published. In Portugal, it is possible to highlight the publication “Informação Sobre Custos na Construção” from the National Laboratory of Civil Engineering. This publication provides quantitative data about construction costs, including profits associated with various building elements and is updated periodically whenever the fluctuations in market prices are higher than 10%.

The assessment of the life-cycle costs is a method that sums the investment costs associated with the period of the life-cycle under study. The total sum is usually presented in two forms: net present value (NPV) or annual cost. This method is used to compare building elements or buildings that meet the same performance level. These comparisons allow checking which solution has lower costs during the period under study and, therefore, the most economical solution.

The method of assessment of life-cycle costs can include the initial investment, the costs of using, the costs of replacement, the costs of maintenance and the costs of repair and the demolition costs and transport to landfill. The residual value, associated with the potential for reuse and recycling, is not generally considered.

In a comparison of the life-cycle costs of two products is essential to consider the same period of each one alternative, even if those have a different useful life. The lifetime to consider in the comparison varies according to intervener's perspective, in the life-cycle of the building, which is performing the study. For example, the owner of a habitation will choose the study period corresponding to the interval of time that he expect to dwell in the habitation, while an owner/holder of an office building may choose a study period corresponding to the whole life-cycle of the building.

In the European market there are some tools for assessing life-cycle costs that were developed specifically for buildings, for example: Kiinteistötieto (Finland), Kostenreferentiemodel Woningbouw (Netherlands) and Årskostnadsanalyse (Norway). The description and comparison of such methodologies as well as the basis for the development of an approach of European scale, for the assessment of life-cycle costs of a building, can be found in the European Commission report entitled “Life Cycle Costs in Construction” (CE, 2003).

5. SYSTEMS TO SUPPORT SUSTAINABLE DESIGN AND TO RATE THE SUSTAINABILITY OF BUILDINGS

5.1. Objectives of the systems

A building may only be considered sustainable if the three different dimensions of sustainability (environmental, social and economic) are considered in its design and utilization.

Sustainability involves various aspects, being the most common those related to reducing the consumption of non-renewable materials and water and also with the production of emissions, wastes and pollutants. The various aspects of sustainability are related to each other and the interaction of the building with its surroundings is also important. In most of the policies to promote the sustainability is common to find the following objectives: optimize the potential of the site, preserving the cultural and regional entity, minimize energy consumption, protect and conserve the resources (including water), use eco-efficient materials, ensuring adequate levels to health and comfort conditions, optimize the use and maintenance practices and minimize life-cycle costs (Bragança, Mateus and Koukkari, 2007).

The connections between the life-cycle of buildings and the three dimensions of sustainable development are numerous. The integrated study of all these criteria for assessment, some quantitative and others purely qualitative, becomes very difficult if not performed through a methodical process.

In order to facilitate the adoption of sustainable practices in construction, there are currently under development and/or application some methods for support and assessment of sustainability in construction. These methods holistically address the concept of "sustainable construction" because it only considers the most important aspects. Thus, the assessment is based on a list of indicators and parameters which can be more or less long, which is considered the most representative for the assessment objectives (Figure 7). An indicator allows evaluate the behaviour of a building against one or more objectives of sustainable construction and a parameter is a measurable or observable property that provides information about a phenomenon, environment and area.

The consideration of all connections between the built environment and the sustainable development would preclude the practical implementation of the concept. In the same sense, the development of methodologies based on long lists of parameters that would include some relevant parameters, would make the process very time consuming and costly, which would undermine the achievement of the objectives.

The support methodologies for design and assessment of sustainability allow the transformation of the concept into objective and tangible goals and are essential for the collection and communication of information, that represent aspects indispensable to decision-making during the different phases of the life cycle of a building.

The first methodology for assessing the environmental performance of buildings emerged in the United States in 1998. Until that time, the buildings "environmentally friendly" were designed based on the perspective that the project teams had about what constituted a "green building". Apart from the fact of recognizing that the "green" buildings should be efficient in terms of resources and low environmental impact, there were no specific criteria for assessment and comparison of the advantages of this type of project. In 1998, the United States Green Building Council (USGBC) launched the LEED (Leadership in Energy and Environmental Design) system and the first assessment methodology destined to the new construction (LEED-NC). This methodology specifies the criteria for the design of a "green" building and allows its classification for further comparison and reporting of results (Kibert, 2005).

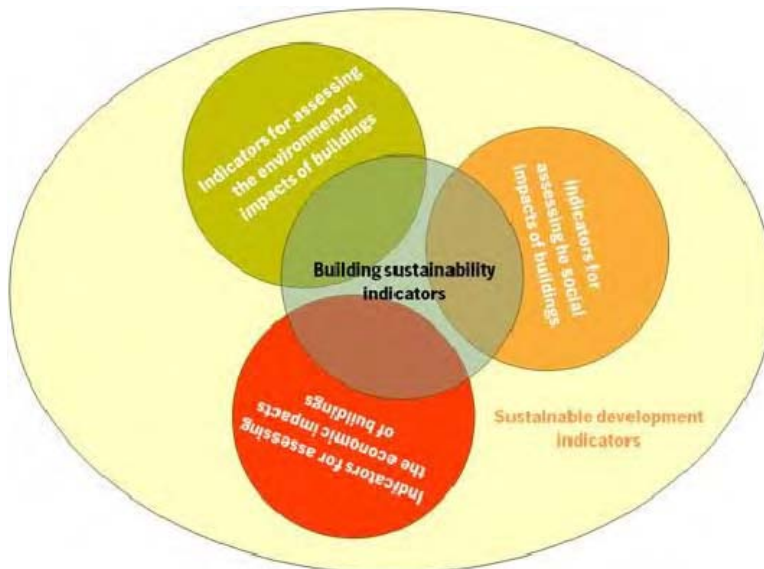

Figure 7: Holistic approach to assessing the sustainability of buildings

The first sustainability assessment methodologies were mainly oriented towards environmental issues and some of them have evolved in recent times in order to incorporate criteria related to social and economic dimensions.

Currently, there is not any approach that is widely accepted on a global scale. This situation is due to some limitations existent in the analysis of buildings, emphasizing among others:

- **Complexity of buildings.** A building is constituted by an endless set of materials, technology and processes. The overall performance of the building does not result from simple summation of the individual performance of each unit of the building, but in how each one relate to each other with users and with internal and external environments. In this way, it is impractical to consider all aspects that influence the sustainability of buildings, so it is only study which are considered more important. The problem is that this simplification is not performed in the same way in the various existing methodologies, as they do not share the same indicators and parameters. This situation complicates the comparison and the interpretation of results obtained;
- **Multidisciplinarity of the life-cycle.** In the life-cycle of buildings, since the phase of extraction of raw materials to the end-of-life, lots of stakeholders are involved. The optimization of the performance of the life cycle of a building should involve the contribution of all stakeholders, which in practice is impossible. On the other hand, multidisciplinarity is further associated with the use of various types of parameters, ones quantitative and qualitative others, which are not expressed in the same quantity and are not correlated (e.g. aesthetics quality vs thermal comfort). In order to avoid the biases caused by the possible inclusion of subjective parameters, some methodologies have chosen the exclusion of such parameters in the evaluation;
- **High quantity of materials.** The analysis of sustainability of products is based on the environmental impact analysis of the life-cycle of used materials. Contrary to what occurs in other products, the buildings are constituted by an endless list of different materials with very different impacts. Additionally, it is extremely difficult to find local databases with the inventory of the environmental impacts associated with all constructive materials used. In some methodologies, this situation is circumvented by considering only part of the materials in the analysis and a summary list of categories of environmental impact. This approach differs from methodology to methodology and presents the risk that, due to lack of data, certain materials that present high impacts are not account for.
- **Low level of industrialization.** Contrary to what happens with other products, in this industry the production processes and the final product are always different. Thus, there may be large deviations between the building designed and the building constructed. This situation complicates not only the estimation of impacts associated with the operational phase as well as the construction phase. The high

amount of uncertainty associated with the construction phase justifies the fact that this phase is ignored in most of existing methodologies.

- **Use phase longer and with greater impacts.** In the phase of use, durability and performance of buildings are conditioned by many variables, ranging from external factors such as climate, to behavioural factors associated with their users. Therefore, it is extremely difficult to estimate, during the design phase, the actual performance of the building in the use phase. This is an important constraint, because unlike what happens in other products, in buildings the use phase is the longest and which results in higher impacts.
- **Political differences, technological differences, cultural differences and socioeconomic differences between countries.** The asymmetries between countries and even within certain countries, between regions, show on one hand that have been developed different lists of indicators and parameters, and on the other hand that have been hierarchized each one of them according to the specific context. Thus, it is not possible to use on a global scale methodologies which the parameters and the system of weights are not adaptable to the reality of where the building will be inserted.

5.2. Brief overview on existing systems

The rating systems differ according to the objective, the analysis scale and the stage of the life-cycle of buildings on which are applied. In 2001, the International Energy Agency, under the project Annex 31, subdivided the various methodologies and tools associated directly and indirectly to the assessment of sustainability of buildings in the following categories (IEA, 2001):

- Energy simulation computer programs;
- Tools for assessing the environmental performance of the life-cycle (LCA) of buildings;
- Methodologies for assessing sustainability and certification systems;
- Directives and checklists for the project and sustainable management of buildings;
- Environmental Product Declarations (EPDs), Catalogs, Databases, Certification Schemes and Tags/Labels.

Table 4 presents the various methodologies that have been identified in countries participating in that project.

Table 4: Listing of various methodologies associated with sustainable construction, according to the project Annex 31 (IEA, 2001)

Country (member of the Annex 31)	Energy simulation programs	LCA tools for the evaluation of buildings	Methodologies for assessing sustainability and certification systems	Directives or checklists for the project and sustainable management of buildings	Environmental product declarations (EPDs), catalogues, databases, certification schemes and tags/labels
Germany	<ul style="list-style-type: none"> • PVCad • SolDesigner • Sombrero 3.01 • SUNDI • T Sol • THERMOSIM 	<ul style="list-style-type: none"> • LEGOE • EcoPro 1.5 			<ul style="list-style-type: none"> • BAU Building Passport • Blue Eco Angel
Australia	<ul style="list-style-type: none"> • ENER_RATE • NatHERS • BUNYIP • ECOTECT • GSL_GISELLE • LCAid 	<ul style="list-style-type: none"> • LISA 	<ul style="list-style-type: none"> • NABERS 	<ul style="list-style-type: none"> • Environment • Design Guide 	<ul style="list-style-type: none"> • EcoSpecifier
Canada	<ul style="list-style-type: none"> • BASECALC • CATALOGUE • EE4 CBIP • EE4 CODE • ENERPASS • FRAME4 • FRAMEplus • GS2000 • Lighting Boy • VISION4 • HOT2000 	<ul style="list-style-type: none"> • The Athena Model 	<ul style="list-style-type: none"> • GBTool • HOMERUN (Energide) • Cities for Climate Protection • Solution Spaces • Quest 	<ul style="list-style-type: none"> • Banff Green Development Guidelines 	<ul style="list-style-type: none"> • Environmental Choice • Super E • Advanced Building Technology
Denmark	<ul style="list-style-type: none"> • BSIM2000 • tsi3 		<ul style="list-style-type: none"> • EDIP • BEAT 	<ul style="list-style-type: none"> • Environmentally Friendly Construction Guide 	
United States of America	<ul style="list-style-type: none"> • EnergyPlus • Visual DOE • BTU Analysis • Building Design Advisor • Building Energy Analyser • COMIS • Daylight • [there are more than 80 tools¹] 	<ul style="list-style-type: none"> • BEES 	<ul style="list-style-type: none"> • INDEX • Smart Places • LEED* 	<ul style="list-style-type: none"> • Built Green • Minnesota Sustainable Design Guide • NYC High Performance Building Guide • City of Santa Monica Green Building Design & Construction Guidelines 	<ul style="list-style-type: none"> • Green Building Advisor
Finland	<ul style="list-style-type: none"> • BUS++ • RIUSKA • SMOG 	<ul style="list-style-type: none"> • LCA-HOUSE • TAKE-LCA 	<ul style="list-style-type: none"> • BSEA 1.0 	<ul style="list-style-type: none"> • ECOPROP 	<ul style="list-style-type: none"> • Environmental Classification of Properties

¹ For more information about the energy simulation computer programs existing in the USA, please visit the internet: http://www.eere.energy.gov/buildings/tools_directory/

Table 4 (cont.): Listing of various methodologies associated with sustainable construction, according to the project Annex 31 (IEA, 2001)

Country (member of the Annex 31)	Energy simulation programs	LCA tools for the evaluation of buildings	Methodologies for assessing sustainability and certification systems	Directives or checklists for the project and sustainable management of buildings	Environmental product declarations (EPDs), catalogues, databases, certification schemes and tags/labels
Japan	<ul style="list-style-type: none"> NIRM 	<ul style="list-style-type: none"> LCCO2 BRI LCA 		<ul style="list-style-type: none"> ECDG Green Housing A-Z Tokyo Metro Green Building Program 	<ul style="list-style-type: none"> MOC Checklist for Government Buildings
Norway			<ul style="list-style-type: none"> EkoProfile 		<ul style="list-style-type: none"> Swan Ecolabel
New Zealand	<ul style="list-style-type: none"> Bench 				
Netherlands	<ul style="list-style-type: none"> NEN 2916: Energy Performance of office buildings NPR 2917: Energy Performance of office buildings – Calculation program NEN 5128: Energy Performance of housing buildings NPR 5129: Energy Performance of housing Buildings calculation program 	<ul style="list-style-type: none"> EcoQuantum Eco-Instal MMG 	<ul style="list-style-type: none"> GreenCalc EcoIndicator 	<ul style="list-style-type: none"> National Packages Sustainable Building Costing Reference Model 	<ul style="list-style-type: none"> Dutch MRPI
United Kingdom	<ul style="list-style-type: none"> APACHE Building Energy Modeling & Simulation ESP-r FLOVENT FLUCS INDUS LifeCYcle Microflo Pisces Radiance Interface ShadowFX Solacalc Suncast TAPS TAS 	<ul style="list-style-type: none"> ENVEST 	<ul style="list-style-type: none"> BREEAM SPeAR 	<ul style="list-style-type: none"> Environmental Management Toolkits 	<ul style="list-style-type: none"> Environmental Profiles of Construction Materials
Switzerland	<ul style="list-style-type: none"> ACOUSALLE LESO-[Tools] 	<ul style="list-style-type: none"> OGIP* 	<ul style="list-style-type: none"> E2000* Ökobau 	<ul style="list-style-type: none"> Planer Kit for Controlled Ventilation systems SIA D0122: Ecology and buildings 	<ul style="list-style-type: none"> Ecological Submission Document SIA 493: Declaration form for building products Embodied energy of building materials

Table 4 (cont.): Listing of various methodologies associated with sustainable construction, according to the project Annex 31 (IEA, 2001)

Country (member of the Annex 31)	Energy simulation programs	LCA tools for the evaluation of buildings	Methodologies for assessing sustainability and certification systems	Directives or checklists for the project and sustainable management of buildings	Environmental product declarations (EPDs), catalogues, databases, certification schemes and tags/labels
Sweden	<ul style="list-style-type: none"> • ID-HAM • CELLAR • DEROB-LTH • EED • HEAT2 • HEAT3 • IDA Indoor Climate and Energy • SLAB 	<ul style="list-style-type: none"> • EcoEffect • LCAiT 	<ul style="list-style-type: none"> • The Natural Step 		

In an attempt to correct its limitations, most of the above methods are constantly evolving. Currently, the main objective is the development, implementation and systematization of a methodology for the design of buildings whose behaviour is optimized in terms of the three dimensions of sustainable development while being practical, transparent and flexible enough to be easily adapted to the different types of buildings and to the constant technological evolution.

5.3. Assessment and certification of the sustainability of buildings - the particular case of the SBTool^{PT} system

Currently it is possible to find on the market some products, solutions and buildings that call themselves more sustainable than conventional. However, some of them may not actually show any advantage compared to conventional solutions, whereby the label "sustainable" is used only in order to potentiate the increase in sales. It is therefore essential to proceed to the assessment of the sustainability of buildings or of the building elements in order to identify those that really enhance a more sustainable future for construction. In this sense, with the growing concern on the one hand, to introduce the concept of sustainability in construction and on the other hand, to recognize the efforts of the project teams in the development of more sustainable solutions, several systems have been developed that allow to recognize and evaluate the performance of buildings, and in particular its environmental performance. An important step in the development of these systems was the introduction of certifications to classify the performance of a building and, at the same time, create demonstration mechanisms and continuous improvement of this performance. The systems and tools for assessment and recognition of sustainable construction are intended to ensure the sustainability of buildings during their entire life-cycle, promoting and enabling a better integration between the parameters of environmental, social, functional, economic and other conventional criteria. During the design phase, these systems are important because they allow gathering and reporting information to support decision making towards the integration of the sustainability in the projects. Currently, there are already a number of systems on the market, both internationally and nationally, highlighting below the contribution of the SBTool^{PT} system to the promotion of sustainability of the built environment in Portugal.

The SBTool^{PT} is a voluntary system that has as main objective to support designers from the most preliminary stages of the project, in the development of a more sustainable built environment. On the other hand, allows the evaluation and certification of the sustainability of buildings, new and renovated, located mainly in urban areas. Additionally, the methodology was thought in order to raise awareness among various decision-makers in the Portuguese construction market towards the adoption of solutions that lead to the development of more sustainable buildings. The search for a more sustainable built environment lies on the development of new constructions, on the

rehabilitation of existing buildings and on the creation of urban areas that maximizes its performance at the level of each of the pillars of the Sustainable Development: Environment, Society and Economy. Additionally, this system can also be used to certify the level of sustainability through the Portuguese brand SBTool^{PT} - System for Assessment and Certification of Sustainability in the Built Environment.

This approach is based on the structure of the international system of sustainability evaluation SBTool (*Sustainable Building Tool*). The SBTool is an international system, voluntary, of evaluation and recognition of the sustainability of buildings, which was developed by the non-profit association iiSBE (International Initiative for a Sustainable Built Environment) and is the result of collaboration in consortium of teams from over 20 countries. The SBTool^{PT} was adapted to the Portuguese reality by national representation of iiSBE (Association iiSBE Portugal), em in collaboration with the Laboratory of Physics and Technology of Constructions at the University of Minho (LFTEC-UM) and the private sector company EcoChoice. Its adaptation was accompanied by iiSBE International and similar approaches currently exist in Spain, Italy and Czech Republic.

The system is based on an Evaluation Guide and is based on a set of 25 indicators and 9 categories that summarize the behaviour of a project in relation to some key aspects of the sustainability (Figure 8) (Mateus & Bragança, 2011). Its structure allows evaluating and certifying the behaviour of a project in relation to two reference levels (adapted to the national context): best practice and conventional practice (Mateus & Bragança, 2011).

This tool classifies the sustainability of a building through six qualitative levels of performance, which vary on a scale ranging from A+ (more sustainable) and E (less sustainable). In this system, a building presents a level of performance higher than D if it is more sustainable than a conventional building in the Portuguese context. In Figure 9 is shown the appearance of the Certificate of Sustainability of this evaluation system.

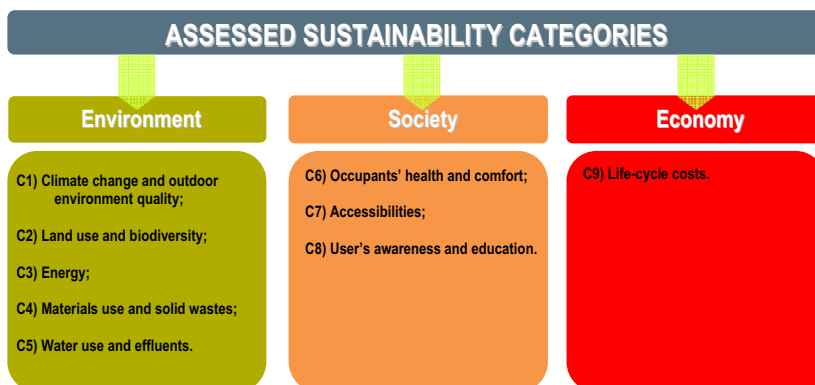

Figure 8: Dimensions and categories of the SBTool^{PT} system



Figure 9: (a) label used to communicate the level of global sustainability through the SBTool^{PT} system; (b) Certificate used to communicate the sustainability of a building evaluated through the SBTool^{PT} methodology

6. DEVELOPMENT OF THE LIFE CYCLE ANALYSIS (LCA) DATABASE

6.1. Objectives and Scope

Installation, maintenance and dismantling of materials and constructive elements are associated, both internationally and in Portugal, to the consumption of significant amounts of energy and resources (inputs) and to the production of waste (outputs). In order to facilitate the accounting of the potential environmental impact associated with those inputs and outputs and to promote the use of solutions with lower environmental impact by the project teams, is presented in this work a database with the quantification of the environmental impact categories associated with two stages of the life cycle (cradle-to-gate and end-of-life) of many constructive elements and construction materials and to the phase of use of some air conditioning equipment. The database developed is presented in Annex II and is titled "Database of LCA".

As mentioned earlier, the use of certain materials and constructive technologies can contribute considerably to improve the environmental performance of the life cycle of a building and consequently its sustainability. It is currently widely accepted that, under the Sustainability Assessment of Construction (ASC), the Life-Cycle Analysis (LCA) is the best method to evaluate the environmental impacts caused by materials, products and constructive elements for the entire life-cycle of buildings. However, reality shows that LCA tools are not widely used in the design of buildings and most of the systems of sustainability assessment of buildings do not use this method in the evaluation of environmental impacts (Bragança & Mateus, 2008). The two main reasons, which are usually mentioned for poor utilization of the LCA method in design of buildings and in the ASC processes, are: the large variety and quantity of materials and processes used in the life cycle of buildings and the complexity of the phases of the LCA method.

For the above reasons, in most of the systems of sustainability assessment, the evaluation of environmental performance is not based on a LCA method and is not based on a standard set of categories of environmental impact. For this reason, the environmental indicators used vary from system to system, making it difficult to compare results.

As stated above, in order to rectify this situation at European level, the European Centre for Standardisation (CEN) has undergone a Technical Committee (TC 350), whose mandate involves, among other things, to clarify the environmental impact categories that should be used to assess the environmental performance of buildings. According to the work in progress in CEN, evaluations should consider the quantification of six environmental impacts expressed in categories of environmental impact of LCA, which are presented in Table 3.

As the quantification of environmental impact categories is a long and complex process, the list presented in Table 3 was developed to enable the direct use of environmental impacts that are usually presented in the Environmental Product Declarations (EPDs). However, at present, the number of companies of construction materials or products that have or which advertise the EPDs of their products is very low. Thus, the current solution passes through the use of external LCA tools and methods for quantifying those categories. Since most of the project teams do not dominate the phases of the LCA method, this solution is not, in the most part, viable and therefore turns out to constitute an important barrier to more accurate evaluations.

For the above reasons, this work was aimed to quantifying the environmental impact categories presented in Table 5 for some of the building elements and materials more used in the construction of buildings in Portugal and its publication in a database. Besides the values corresponding to the six environmental indicators presented in that table, the database contemplates two environmental impacts based on data of life-cycle inventory (LCI), but not expressed in LCA categories: i) incorporated non-renewable energy; and ii) incorporated renewable energy.

Table 5: Environmental impact indicators considered in the database of LCA data developed

Environmental impacts expressed in categories of LCA	Environmental impacts based on data of life-cycle inventory (LCI), but not expressed in categories of LCA
<ul style="list-style-type: none"> • Abiotic depletion of resources (ADP); • Global Warming Potential, expressed in terms of emissions of greenhouse gases (GWP); • Destruction of the stratospheric ozone layer (ODP); • Acidification of soil and water resources (AP); • Tropospheric ozone formation, expressed in photochemical oxidants (POCP); • Eutrophication (EP). 	<ul style="list-style-type: none"> • Use of non-renewable primary energy (ENR); • Use of renewable primary energy (ER).

Therefore, project teams might directly import from the database the value of environmental impact categories corresponding to building elements used and thus easily calculate, without any expertise in the field, the environmental impact of the life-cycle of the building in assessment. The database developed can be used directly in the evaluation of the Sustainability Category "C1 - Climate change and quality of the outside environment" of the Portuguese system of evaluation and certification of sustainability SBToolPT.

In sum, with the development of this database, it is intended, on the one hand to provide to designers the environmental performance of some building elements and construction materials commonly used in buildings in Portugal, so that they can take appropriate options aimed to minimize the impacts and on the other hand, to enable the assessment of the environmental performance of the building based on a standardized LCA method.

At this stage the database developed covers some of the building elements most used in each of the constructive elements, the construction materials most used in building construction in Portugal and the environmental impacts associated with the use of some air conditioning systems and heating of sanitary water (ACS). This work is divided into three sections:

- Environmental impacts embedded in building elements (subdivided floors, exterior walls, interior walls, roofing and glazing);
- Environmental impacts embedded in construction materials;
- Environmental impacts associated with the use of air conditioning equipment and of ACS.

In the current version, the Database LCA covers a total of 107 building elements (16 of floors, 28 of exterior walls, 22 of interior walls, 23 of toppings and 18 types of glazing), 47 construction materials and the environmental impact associated with the use of 12 air conditioning equipments and heating of sanitary water. The detailed description of the building elements analyzed is presented in Annex I of this publication. Due to the infinity of solutions and of construction materials that currently exist and due to the new solutions and materials that often arise in the market, it is intended that future versions of this work cover a larger number of building elements and of construction materials.

As shown in Figure 10, the normal life cycle of a building can be described in three distinct phases, each comprising one or more stages of the life-cycle: assembly phase, operation phase, and end-of-life phase. The assembly phase refers to the impacts related to: collection of raw materials by resource extraction or recycling; transformation of these raw materials into products; transportation of the products to the construction site; assembly of the products for the materialization of the building; and substitution of the constructive elements during the maintenance phase of the building. The operation phase is related to the impacts resulting from energy consumption for air conditioning, appliances, lighting and heating of sanitary water. Finally, the disassembly phase include: the processes related to the deconstruction/demolition of the building; the transportation of the waste to the treatment site; and the scenario of treatment considered for each type of waste generated (landfill and/or recycling).

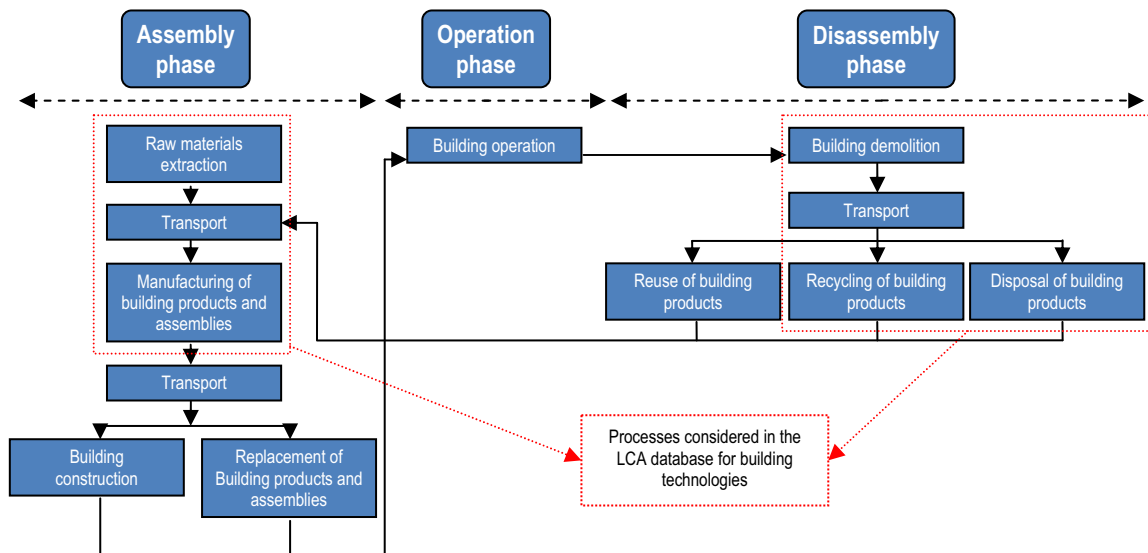

Figure 10: Conventional phases of the life-cycle of a building and processes contemplated in the LCA database of building elements

As can be seen in Figure 10, part of the **LCA Database of Building Elements** covers the impacts cradle-to-gate and the end-of-life associated with the materials used in each constructive solution. With the exception of the glazing, the functional unit considered in this part of the database was of 1m², so the values presented correspond to the impact associated with the materialization of 1m² of constructive solution. In the case of glazing, the presented figures correspond to a glass with the standard dimensions of: 1,48*1,25 m². In cradle-to-gate impacts it was considered the processes corresponding to the extraction of raw materials, transporting them to the place of processing and with its processing. This generation of the database does not include: the impacts arising from the transportation of materials and construction products to the construction site; the impacts associated with the processes of construction in site and the impacts related to scenarios for building maintenance during its useful life. The end-of-life phase refers to the impacts associated with the end-of-life scenario that has been adopted and which consists in the following:

- Were discarded the impacts associated with the processes of deconstruction/demolition;
- Average distance of transportation of waste from deconstruction/demolition to the place of treatment/disposal equal to 50 km, using an average tonnage truck;
- Recovery to recycling of 80% of metals chemically bonded to another type of material;
- Recovery to recycling of 95% of metals mechanically bounded to another type of material;
- Deposition of the remaining waste in a landfill for inert.

The part of the **LCA Database of Construction Materials** includes only the impacts corresponding to the cradle-to-gate phase. In this part, the functional unit used was 1kg, whereby the values presented refer to the production of 1kg of material. In the quantification of impacts associated with the production of construction materials were considered the processes corresponding to the extraction of raw materials, transporting them to the place of processing and with its processing. This part of the database aims that the designers in an expeditious estimate the value of the environmental indicators of building elements that are not in the database.

As regards the part of the **LCA Database of AVAC and hot water Heating Equipment**, this aims to provide to designers impacts related to energy consumption during the operation phase of the building, depending on the type of equipment and fuel being used. In this case, the functional unit considered is 1 kW.h of energy produced by the equipments. In this analysis it was not included processes related to the production of the equipments and its transportation to the construction site.

6.2. Life-cycle Inventory

After defining the objective and scope of the LCA Database, the next step was to perform the inventory analysis of all inputs and outputs associated with the life-cycle of each of the building elements, materials and equipment covered.

The first stage was focused on the measurement of each type of material used per m² of constructive solution. This process was based on the income sheets published by the National Laboratory of Civil Engineering (LNEC) (Manso, Fonseca & Espada, 2004). These sheets present a set of construction operations, identifying the amount of materials and products of construction used.

To quantify the inputs (raw materials, energy, etc.) and emissions (emissions to air, emissions to soil, etc.), related to the use of construction materials accounted for in the previous stage and essential to quantify the environmental impacts, it was used mainly databases with the inputs and average emissions corresponding to the context of Western Europe. This solution was due to the fact that in Portugal LCI data are not available for most of the construction materials and products produced. The known values that are published refer to studies conducted by the Technological Centre of Ceramics and Glass to the national ceramic industry (Almeida, Dias & Arroja, 2011). Thus, in the absence of national LCI values recourse was had preferentially to the use of the database Ecolnvent v2.2 (SCLCI, 2010), because this is, in the field of construction, more current and embracing. However, whenever this database did not include a specific material, the solution passed through the utilization of another that could contemplate this information. In the development of this work were used a total of seven LCI databases, namely:

- Environmental Product Declaration (EPD) for masonry ceramic produced in the Portuguese context (Almeida, Dias & Arroja, 2011);
- Ecolnvent V2.2 (SCLCI, 2010)
- IDEMAT 2001 (FIDE-DUT, 2001)
- ETH-ESU 96 (OE, 1996);
- BUWAL 250 (SAEFL, 1998);
- DK INPUT OUTPUT (DST, 2010);
- Ecology of Building Materials (Berge, 2000).

6.3. Quantification of the categories of environmental impact

The modelling of the stages of the life cycle of building elements, materials and equipment for the quantification of environmental indicators was performed using the computer program SimaPro v7.2 (Pré-consultants, 2010). This program integrates international LCI databases mentioned in the previous section and several LCA methods for converting material flows and their LCI values in potential environmental impacts.

For the quantification of categories of environmental impact it was used three intermediate methods of LCA: the method "CML 2 baseline 2000" (CML, 2001), the method "Cumulative Energy Demand" (Frischknecht *et al*, 2003) and the method "IPCC 2001 GWP" (CC, 2001).

In Table 6 are related the categories of environmental impact with the method used in their quantification and are presented the units that are expressed in each of them.

Table 6: LCA Method and units used in the quantification of each of the categories of environmental impact

Categories of environmental impact	Acronym	LCA method	Unit
Abiotic resources Depletion Potential	ADP	CML 2 baseline 2000	kg Sb eq
Global Warming Potential	GWP	IPCC 2001 GWP	Kg CO ₂ eq
Ozone Depletion Potential	ODP	CML 2 baseline 2000	Kg CFC-11 eq
Acidification Potential	AP		kg SO ₂ eq
Photochemical Ozone Creation Potential	POCP		Kg C ₂ H ₄ eq
Eutrophication Potential	EP		kg PO ₄ eq
Incorporated non-renewable energy	ENR	Cumulative Energy Demand	MJ eq
Incorporated renewable energy	ER		MJ eq

In order for the projectors better understand the importance of the categories of environmental impact considered in this study, are presented below and in a briefly way environmental mechanisms associated with each one (Pré-consultants, 2008).

6.3.1. Abiotic resources Depletion Potential (ADP)

This category of environmental impact is related to the protection of the comfort and health of the human being and with the preservation of ecosystems. The category ADP aims to assess the environmental problem associated with the decreasing availability of natural resources. It is understood by natural resources minerals and materials found on the land, sea or atmosphere, including fossil fuels. Its value is related to the amount of each material and fossil fuel extracted and is based on available reserves and decrease rate thereof. The ADP is expressed in equivalent kilograms of antimony (Sb) per kilogram of extracted resource. This indicator has repercussions on a global scale.

6.3.2. Global Warming Potential (GWP)

Climate change may result in adverse effects to human health, to ecosystem preservation and to performance of materials. This category is related to the emission of greenhouse gases into the atmosphere and is expressed as Global Warming Potential, for a time horizon of 100 years (GWP100), in equivalent kilograms of carbon dioxide (CO₂) per kg of emissions released to the atmosphere. This indicator has repercussions on a global scale and is related not only to the radioactive properties of emissions, but also with the time scale that characterizes and depletion of the substance in the atmosphere.

6.3.3. Ozone depletion potential (ODP)

With the destruction of the stratospheric ozone layer increases the amount of UV-V radiation reaching the terrestrial surface. This situation may have negative effects on human health, on animal health, on balance of terrestrial ecosystems, on aquatic and biochemical cycles, and on the durability and performance of materials. The characterization model used was developed by the World Meteorological Organisation (WMO), that defined the ozone depletion potential of different gases in equivalent kilograms of trichlorofluoromethane (CFC-11) per kilogram emission. The geographic scope of this indicator is the global scale. The time scale of the effects is infinite.

6.3.4. Acidification Potential (AP)

Acidification is the process where emissions to air (primarily ammonia (NH₃), sulphur dioxide (SO₂) and nitrogen oxide (NO_x)) are converted to acid substances. The sulphur dioxide is formed by the burning of fossil fuels such as coal, which contain high quantities of sulphur; the nitrogen oxide is produced by various industrial activities and is present in emissions from the transport sector. This indicator is expressed in equivalent kilograms of SO₂ for each kilogram of emissions to the atmosphere. Acidifying compounds released into the atmosphere are transported by

wind and deposited as acid particles or acid rain to hundreds or thousands of km away from the source. Acid rain is considered an important example of cross boarder pollution (international). Acidification occurs when the capacity of soil organisms or of water to resist or neutralize the atmospheric deposition of acidifiers starts to decrease. The acid substances can attack natural and artificial materials, and cause damage to capital, to human health and to natural values. Materials such as cement, lime and concrete are sensitive to acid, as this can react with its contents and disintegrate the material structure. The acids can also cause considerable corrosion of metal surfaces. The geographic scope of this indicator can be both local and continental. The time scale is infinite.

6.3.5. Photochemical Ozone Creation Potential (POCP)

The photochemical oxidation corresponds to the formation of reactive chemical compounds (mostly ozone) by the action of ultraviolet radiation (UV). This problem is also known as "summer smog". Currently, tropospheric ozone is one of the most serious air pollutants in Europe. High levels of ozone cause severe health problems, premature death, reduced productivity of agricultural crops, changes in biodiversity and damage to property. The chemical compounds related to this problem, such as nitrogen oxides (NO_x), carbon monoxide (CO) and volatile organic compounds (VOCs) are emitted into the atmosphere from many natural and anthropogenic processes. In the lower part of the Earth's atmosphere, the troposphere, and under the influence of UV radiation photo-oxidants are formed by photochemical oxidation of VOCs and CO in the presence of NO_x. These reactions lead to the formation of ozone (O₃), peroxyacetyl nitrate (PAN), peroxybenzoyl nitrate (PBN) and a number of other substances. In human beings, low concentrations of photochemical smog may cause reduced functionality of the lungs, chest tightness, eyes, and nose and throat irritation. At higher concentrations can cause coughing and decreased ability to concentrate. Regarding to materials, ozone attack natural rubber, cellulose, synthetic polymers, etc., and reduces the lifetime of many materials (textiles, car tires, etc.). This indicator is expressed in equivalent kilograms of ethylene (C₂H₄) per kilogram of emission. These emissions have an effect that is maintained for 5 days and this mechanism has local and continental repercussions.

6.3.6. Eutrophication Potential (EP)

Eutrophication, also known as nitrification, includes all impacts due to excessive levels of macro-nutrients in the environment caused by nutrient emissions to air, to water and to soil. Nutrients are normally added to the soil through fertilization to stimulate the growth of plants and agricultural products. When these nutrients end in natural waterways or sensitive soils, this unintentional fertilization may result in excess of plants or algae which, in turn, can lead to lack of oxygen and consequently to death of species. This environmental problem is usually associated to the emissions of nitrogen (N) and phosphorus (P). The potential of eutrophication is expressed in equivalent kilograms of phosphate (PO₄) per kilogram of emission. The duration of this environmental impact is infinite and it has local and continental repercussions.

6.3.7. Embodied non-renewable energy (ENR)

This indicator expresses the consumption of non-renewable energy associated with the phases of the life-cycle of the product under study and thus represents the contribution from the product to the depletion of non-renewable energy resources. This indicator is expressed in equivalent mega joules (MJ) and includes fossil and nuclear energy consumed.

6.3.8. Embodied renewable energy (ER)

This indicator does not express negative environmental impacts. In most cases, it serves to demonstrate the concern of a particular producer in the use of renewable energy sources rather than non-renewable sources. This indicator is expressed in equivalent mega joules (MJ) and includes fossil and nuclear energy consumed.

6.4. Structure and use of the LCA database

Figure 11 shows, as an example, how information resulting from quantification of the categories of environmental impact of one of the building elements analyzed is organized in the LCA database developed. In this case, the values presented for the categories of environmental impact are those related to the construction of 1 m² of double-wall of masonry of brick holed (15cm +11 cm) with thermal isolation in EPS in the box of air.

Building element	Double masonry brick wall (15cm +11 cm) with thermal insulation (EPS) in the air gap							Ref: Par 1	
	Life-cycle phase	Environmental LCA impact categories					Embodied energy		
		ADP	GWP	ODP	AP	POCP	EP	ENR	ER
	Cradle-to-gate	3.70E-01	9.53E+01	1.02E-04	1.91E-01	1.13E-02	2.54E-02	8.68E+02	1.01E+02
	End of life	2.08E-01	3.17E+01	5.00E-06	1.42E-01	5.40E-03	2.95E-02	4.75E+02	2.83E+00
	Total	5.78E-01	1.27E+02	1.07E-04	3.33E-01	1.67E-02	5.49E-02	1.34E+03	1.04E+02
	Materials Considered: Brick holed, extruded polystyrene foam (thermal insulation), laying mortar and grout (coating)								
	Comments: LCA Method(s): CML 2 baseline 2000 version 2.04 (To evaluate the environmental impact) and Cumulative Energy Demand version 1.04 (To evaluate the energy)								
	LCI Libraries: Ecoinvent system process								

Figure 11: Mode as the environmental information of a constructive solution is structured in the LCA database

The database developed enables the quantification of the environmental impacts of the life-cycle of a building through a bottom-up approach, i.e. the environmental impact of the life-cycle of a building results from the sum of the environmental impact associated to each constructive solution (including impacts related to maintenance and to the end of life scenario) with the impact associated to the energy consumption during the use phase. The way in which information is structured, allows estimating the environmental impacts of the life-cycle of a building in two stages.

The first stage corresponds to the quantification of environmental impacts incorporated into building elements used. This stage includes the quantification of the total number of square meters of each constructive solution used and its multiplication by the impacts corresponding to 1m² of each solution (which are presented in the LCA Database of building elements). When a particular constructive solution is not available on the Database, the assessor can estimate the value of the categories of environmental effects through the use of the LCA Database of Materials. In this section of the database impacts are expressed by the quantity (kg) of material.

In the second stage is quantified the environmental impact of the building life-cycle, adding the result obtained in the previous stage with the impacts corresponding to the operations of maintenance and energy consumption in the use phase. Table 7 summarizes the methodology to be adopted for quantifying the impact of the life-cycle of a building, using the LCA Database presented in this publication.

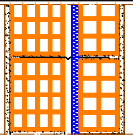
Table 7: Principle to be adopted for quantifying the impacts of the life cycle of a building

Building element (C _i)	Area (m ²)		Environmental impact categories							
C ₁	A ₁	X	ADP ₁ /m ²	GWP ₁ /m ²	ODP ₁ /m ²	AP ₁ /m ²	POCP ₁ /m ²	EP ₁ /m ²	NR ₁ /m ²	R ₁ /m ²
			+	+	+	+	+	+	+	+
(...)	(...)	X	(...)	(...)	(...)	(...)	(...)	(...)	(...)	(...)
			+	+	+	+	+	+	+	+
C _n	A _n	X	ADP _n /m ²	GWP _n /m ²	ODP _n /m ²	AP _n /m ²	POCP _n /m ²	EP _n /m ²	NR _n /m ²	R _n /m ²
			+	+	+	+	+	+	+	+
Environmental impact of the maintenance scenario/m ² .year			ADP _m	GWP _m	ODP _m	AP _m	POCP _m	EP _m	NR _m	R _m
			=	=	=	=	=	=	=	=
Environmental impact incorporated into the building			ADP' _e	GWP' _e	ODP' _e	AP' _e	POCP' _e	EP' _e	NR' _e	R' _e
			+	+	+	+	+	+	+	+
			Duration (in years) for the period of life cycle assessment							
			+	+	+	+	+	+	+	+
			Useful area of the building							
			=	=	=	=	=	=	=	=
Environmental impact incorporated into the building/m ² .year			ADP _e	GWP _e	ODP _e	AP _e	POCP _e	EP _e	NR _e	R _e
			+	+	+	+	+	+	+	+
Environmental impact associated with energy consumption for air conditioning and heating of sanitary waters/m ² .year			ADP _o	GWP _o	ODP _o	AP _o	POCP _o	EP _o	NR _o	R _o
			=	=	=	=	=	=	=	=
Total impact of the life-cycle of the building/m².year			ADP	GWP	ODP	AP	POCP	EP	NR	R

7. FINAL REMARKS

The importance of the built environment, namely buildings, in people's daily lives, reveals the importance and interconnectedness of the construction industry, in terms of actual and potential effects with Sustainable Development. For example, the majority of the population spends most of its time in buildings, places where they live and work. Currently, the main challenge that the construction sector faces is finding the balance between the different constraints normally considered (technical, architectural, etc.) and simultaneously developing products that are sustainable over their entire life-cycle. Overall, it is necessary that Portugal consolidates a change of environmental, social and economic trajectories towards sustainability.

In order that sustainable construction is a reality it is necessary that the stakeholders act accordingly. It is up to the owners and the customers an important role in the dissemination of Sustainable Construction, since they represent the demand in the construction sector. Manufacturers of construction products and materials should consider life-cycle analysis (LCA) as the basis of their developments and should also cooperate with designers and I&D centres to create new products. Designers should adopt an integrated approach in the design processes, analyzing all the fundamentals that are aimed at developing more sustainable solutions and interpreting correctly the various forms of communication (labelling) of environmental performance and/or sustainability of products available in the market, so they can opt for those with real gains in this area. Project teams should consider the environmental qualities incorporated in a given construction product or material and also how the interaction of the various materials adopted for a building affects the environmental, social and economic development of all of its life-cycle. Construction and maintenance companies must understand sustainability as a current challenge in an increasingly competitive market. Users should look at sustainability issues as an aspect that, in addition to improving the environmental performance of their buildings (with all the advantages at local and global scale), also translated into increased comfort and lower operation costs.

The development of this work, namely the LCA Database presented, aimed at promoting the practical use, by common project teams, of an internationally accepted LCA methodology for quantifying the environmental impact categories. In the present version, the LCA Database contains a total of 107 building elements (16 floors, 28 external walls, 22 internal walls, 23 finishing solutions and 18 types of glazing), 47 construction materials and the environmental impact associated with the operation of 12 AVAC and sanitary hot water heating equipment. This database should be regularly updated to incorporate the latest versions of LCI databases and used LCA methods, and to cover the largest number of building elements that are commonly used in construction and appear regularly on the market.

At the end, it is expected that the results obtained in this work constitutes a contribution to the various stakeholders of construction, particularly for project teams, in decision-making towards the improvement of the performance of buildings with lower life-cycle environmental impact and, therefore, more sustainable.

8. REFERENCES

- Almeida, Dias & Arroja (2011). Declaração Ambiental de Produto para Cerâmicos de Alvenaria. Seminário Paredes 2011. Porto.
- Berge B. (2000). Ecology of Building Materials. Architectural Press: England.
- Bragança L., Mateus R. (2008). New Approach to Life-Cycle Analysis in Building Sustainability Rating Systems. Congresso de Inovação para a Construção Sustentável (CINCOS'08), 23 a 25 de Outubro, Cúria.
- Bragança L, Mateus R, Koukkari H. (2010) Building sustainability assessment. Sustainability 2010;2(7):2010-23.
- Carmody J., Trusty W., Meil J., Lucuik M. (2007). Life cycle Assessment tool for building assemblies. In: Proceedings of the Sustainable Construction, Materials and Practices Conference, Portugal SB07, Lisbon, Portugal.
- CC (2001). IPCC Third Assessment Report. Climate Change 2001. The Scientific Basis. http://www.grida.no/climate/ipcc_tar/
- CEN (2011). CEN TC 350. Sustainability of construction work. Executive summary [web page], <http://www.cen.eu/CEN/sectors/TechnicalCommitteesWorkshops/centtechnicalcommittees/Pages/PdfDisplay.aspx>
- DGGE (2005). Caracterização Energética Nacional. Direcção Geral de Geologia e Energia. <http://www.dgge.pt>.
- DST (2010). DK Input Output database. Statistics Denmark. Denmark.
- FIDE-DUT (2001). IDEMAT 2001 database. Faculty of Industrial Design Engineering of Delft University of Technology. Delft, Netherlands.
- Erlandsson M., Borg M. (2003) Generic LCA-methodology for buildings, constructions and operation services e today practice and development needs. Building and Environment 2003;38:919-38.
- Forsberg A., Malmberg von F. (2004). Tools for environmental assessment of the built environment. Building and Environment 2004;39(2):223-8.
- Häkkinen T., Huovila P., Tattari K., Vares S., Seppälä J., Koskela S., *et al.* (2002). Eco-efficiency in the building and real estate sector, vol. 580. Helsinki: Ministry of Environment, Housing and Building Department, the Finnish Environment; 2002. 165 p.
- IEA (2001). IEA ANNEX 31 – Energy Related Environmental Impacts of Buildings. International Energy Agency (IEA). Document available online at [<http://www.eere.energy.gov/buildings/info/operate/buildingcommissioning.html>] a 06/03/2007.
- INAG (2005). Inventário Nacional de Sistemas de Abastecimento de Água e de Águas Residuais – INSAAR 2005. Instituto da Água, 150 p.
- ISO. ISO/TS 21929-1 (2006). Sustainability in building construction - sustainability indicators - part1: framework for the development of indicators for buildings. Geneva: ISO.
- Kotaji S., Schuurmans A., Edwards S. (2003). Life-cycle assessment in building and construction: a state-of-the-art report. SETAC: 2003.
- Lippiatt, B. C. (2002). BEES 2.0 - Building for Environmental and Economic Sustainability. Peer Review Report. NISTIR 6865; 42 p. April.
- Manso A., Fonseca M., Espada, J. (2004). Informações sobre custos – Fichas de rendimentos Volume 1 e 2. Laboratório Nacional de Engenharia Civil (LNEC). Lisboa.
- Mateus R. (2010). Avaliação da sustentabilidade da construção – propostas para o desenvolvimento de edifícios mais sustentáveis. Tese de doutoramento em Engenharia Civil. Universidade do Minho, Guimarães.

Mateus R., Bragança L. (2011). Sustainability assessment and rating of buildings: developing the methodology SBTool^{PT}-H. *Building and Environment* 46 (2011). pp 1962 – 1971.

OE (1996). ETH-ESU 96 database. *Ökoinventare von Energiesystemen*. ESU Group, ETH Technical University of Zürich, 1996.

Pré-consultants (2008). *SimaPro Database Manual – Methods Library*. Amersfoort, The Netherlands: Product Ecology Consultants.

Pré-consultants (2010). *SimaPro 7. LCA software version 7.2*. Amersfoort, The Netherlands: Product Ecology Consultants.

SCLCI (2010). *Ecoinvent v2.2 data*. Swiss Centre for Life Cycle Inventories. St-Gallen, Switzerland.







SAEFL (1998). *BUWAL 250 database. Life cycle inventory for packagings, vols. I and II. Environmental series no. 250/I and II*. Berne, Switzerland: Swiss Agency for the Environment, Forest and Landscape.



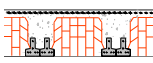
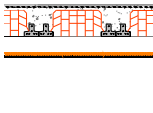
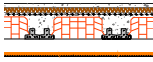

ANNEX I

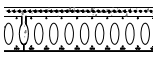
DESCRIPTION OF BUILDING ELEMENTS

AI.1. Floors

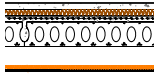
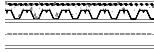
The following tables present the description of the 16 building elements for floors.

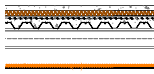
Elements ID	Schematic section	Description
Pav 1		<p>Double joist pavement with a total height of 25cm and a 4cm supplementary concrete layer, equipped with an armature for distribution in electro welded network A50. The formwork blocks are ceramic and feature three rows of holes.</p>
Pav 2		<p>Double joist pavement with a total height of 25cm and a 4cm supplementary concrete layer, equipped with an armature for distribution in electro welded network A50. The formwork blocks are ceramic and feature three rows of holes. The lower coat is disconnected from the slab and separated of it by an air gap 15cm thick. This coating contains plasterboards 1.25cm thick and a 2.5cm blanket of rock wool based on the masonry of plasterboards.</p>
Pav 3		<p>Double joist pavement with a total height of 25cm and a 4cm supplementary concrete layer, equipped with an armature for distribution in electro welded network A50. The formwork blocks are ceramic and feature three rows of holes. The lower coat is disconnected from the slab and separated of it by an air gap 15cm thick. This coating contains plasterboards 1.25cm thick and a 2.5cm blanket of rock wool based on the masonry of plasterboards. For the top coating, this consists of foamed polyethylene sheet of 0.3cm thick, black cork agglomerate with a thickness of 4cm and a lightweight concrete slab (with expanded clay) with 4cm thick.</p>
Pav 4		<p>Solid slab composed pavement with a total height of 20cm.</p>
Pav 5		<p>Solid slab composed pavement with a total height of 20cm. The lower coat is disconnected from the slab and separated of it by an air gap with 15cm thick. This coating contains 1.25 cm thick plasterboards and a 2.5 cm blanket of rock wool based on the masonry of plasterboards.</p>
Pav 6		<p>Solid slab composed pavement with a total height of 20cm. The lower coat is disconnected from the slab and separated of it by an air gap with 15cm thick. This coating contains 1.25cm thick plasterboards and a 2.5cm blanket of rock wool based on the masonry of plasterboards. For the top coating, this consists of foamed polyethylene sheet of 0.3cm thick, black cork agglomerate with a thickness of 4cm and a lightweight concrete slab (with expanded clay) with 4cm thick.</p>
Pav 7		<p>Pavement composed by alveolar panels with a total height of 20cm containing a 4cm complementary concrete layer.</p>
Pav 8		<p>Pavement composed by alveolar panels with a total height of 20cm containing a 4cm complementary concrete layer. The lower coat is disconnected from the slab and separated of it by an air gap with 15cm thick. This coating contains 1.25cm thick plasterboards and a 2.5cm blanket of rock wool based on the masonry of plasterboards.</p>

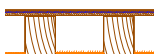
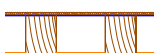
Element ID	Schematic section	Description
Pav 9		<p>Pavement composed by alveolar panels with a total height of 20cm containing a 4cm complementary concrete layer. The lower coat is disconnected from the slab and separated of it by an air gap with 15cm thick. This coating contains 1.25cm thick plasterboards and a 2.5cm blanket of rock wool based on the masonry of plasterboards. For the top coating, this consists of foamed polyethylene sheet of 0.3cm thick, black cork agglomerate with a thickness of 4cm and a lightweight concrete slab (with expanded clay) with 4cm thick.</p>
Pav 10		<p>Pavement composed by a 0.75mm thick cooperating sheet comprising, on which rests a complementary concrete layer with a maximum thickness of 10cm. The main structure is composed of laminated steel profiles INP160.</p>
Pav 11		<p>Pavement composed by a 0.75mm thick cooperating sheet comprising, on which rests a complementary concrete layer with a maximum thickness of 10cm. The main structure is composed of laminated steel profiles INP160. The lower coat is disconnected from the slab and separated of it by an air gap with 15cm thick. This coating contains 1.25cm thick plasterboards and a 2.5cm blanket of rock wool based on the masonry of plasterboards.</p>
Pav 12		<p>Pavement composed by a 0.75mm thick cooperating sheet comprising, on which rests a complementary concrete layer with a maximum thickness of 10cm. The main structure is composed of laminated steel profiles INP160. The lower coat is disconnected from the slab and separated of it by an air gap with 15cm thick. This coating contains 1.25cm thick plasterboards and a 2.5cm blanket of rock wool based on the masonry of plasterboards. For the top coating, this consists of foamed polyethylene sheet of 0.3cm thick, black cork agglomerate with a thickness of 4cm and a lightweight concrete slab (with expanded clay) with 4cm thick.</p>
Pav 13		<p>Discontinuous structure pavement, composed by wooden flooring of 1.8cm, wooden beams with 0.25x0.30m spaced by 0.65m and ceiling coated with plasterboards with 1.25cm thick.</p>
Pav 14		<p>Discontinuous structure pavement, composed by wooden flooring of 1.8cm, wooden beams with 0.25x0.30m spaced by 0.65m suspended ceiling composed by two layers of plasterboards with a total thickness of 2x1.25cm and blanket of rock wool with 8cm applied to the masonry ceiling.</p>
Pav 15		<p>Discontinuous structure pavement, composed by a coating of floating floor (1.8cm) on wooden structural coating (1.8cm), wood beams 0.25 x0.30m spaced by 0.65m, ceiling coated with plasterboards with 1.25cm and blanket of rock wool with 8cm applied to the masonry ceiling.</p>
Pav 16		<p>Discontinuous structure pavement, composed by a coating of wooden floating floor (1.8cm) resting on resilient layer of foam polyethylene sheet (0.3cm), wood beams 0.25x0.30m with spaced by 0.65m, ceiling coated with plasterboards with 1.25 cm and blanket of rock wool with 8cm applied to the masonry ceiling.</p>

AI.2. Exterior walls

The following tables present the description of the 28 analysed building elements for exterior walls.

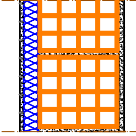
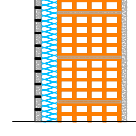
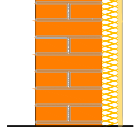
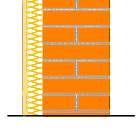
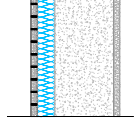
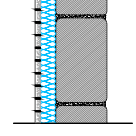
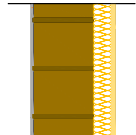
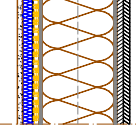
Element ID	Schematic section	Description
PExt 1		<p>Single wall with the support element in masonry of bored brick with 22cm thick. The insulation is in moulded expanded polystyrene plates with 4cm thick. On the insulating layer is located reinforced plaster of mineral binders with 1cm thick.</p>
PExt 2		<p>Single wall with the support element in masonry of bored brick with 22cm thick. The insulation is in moulded expanded polystyrene plates with 6cm thick. The outer shell is in reinforced plaster with 2cm thick.</p>
PExt 3		<p>Single wall with the support element in masonry of massive brick with 22cm thick. The insulation is a layer of mineral wool with 6cm thick. The inner liner is comprised of plasterboards of 1.2cm thick, supported by a galvanized steel structure composed by placements and amounts.</p>
PExt 4		<p>Single walls with the support element in masonry of solid brick with 22cm thick. The insulation is the extruded expanded polystyrene moulded in plates, with 6cm thick. The outer shell is in reinforced plaster with 2cm thick.</p>
PExt 5		<p>Single wall with the support element in reinforced concrete with 20cm thick. The insulation is the extruded expanded polystyrene moulded in plates, with 6cm thick. The outer shell is in reinforced plaster with 2cm thick.</p>
PExt 6		<p>Single walls with the support element in stone masonry with 20cm thick. The material selected for insulation of this element was the extruded expanded polystyrene moulded in plates, with 6cm thick. The outer shell is in reinforced plaster with 2cm thick.</p>
PExt 7		<p>Single wall with the support element in masonry of adobe with 20cm thick. The insulation is rock wool plates, with 6cm thick. The inner liner is comprised of plasterboards of 1.2cm thick, supported by a structure of galvanized steel composed by placements and amounts. The exterior vestment is coated with traditional plaster with 0.5cm thick.</p>
PExt 8		<p>Light wall of structure in profiles of cold rolled steel with 14cm in height. The inner lining is composed of two layers of gypsum plasterboards with a total thickness of 2.5cm. The outer shell is made by structural coating and by composite coating of continuous thermal insulation from the outside. The coating is formed by structural OSB panels, with 1.2cm thickness, mechanically fixed to the structure. On the OSB panels is fixed the insulating layer - moulded expanded polystyrene in plates - with 1cm thick, followed by, finally, the reinforced plaster with mineral binders of 1cm thickness. The cavity formed between the inner and outer is filled with layers of webs of rock wool, which comprise a total thickness of 14cm.</p>

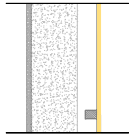
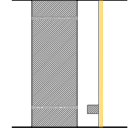
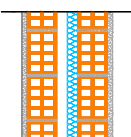
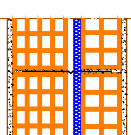
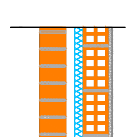
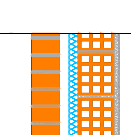
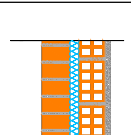
Element ID	Schematic section	Description
PExt 9		<p>Single wall with the support element in reinforced concrete of 20cm. The support element is separated from the inner liner by a box-of-air with 9cm in thickness. The inner liner is in plasterboards with 1.2cm thick. The exterior vestment is coated with traditional plaster with 2cm thick.</p>
PExt 10		<p>Single wall with the support element in stone masonry of 20cm. The support element is separated from the inner liner by a box-of-air with 9cm in thickness. The inner liner is in plasterboards with 1.2cm thick.</p>
PExt 11		<p>Double wall with an exterior cloth in masonry of bored brick of 11cm and an interior cloth in masonry of bored brick of 11cm. The cloths are separated by a box-of-air with 4cm thick, partially filled with insulation in plates - extruded expanded polystyrene - with 4cm thick and fixed to the inner cloth. The interior and exterior vestments are coated with traditional plaster with thickness of 2cm.</p>
PExt 12		<p>Double wall with an exterior cloth in masonry of cast brick of 15cm and an interior cloth in masonry of cast brick of 11cm. The cloths are separated by a box-of-air with 4cm thick, partially filled with insulation in plates of extruded expanded polystyrene with 2cm thick and fixed to the inner cloth. The interior and exterior vestments are coated with traditional plaster with thickness of 1,5cm.</p>
PExt 13		<p>Double wall with an exterior cloth in masonry of mass brick of 11cm and an interior cloth in masonry of bored brick of 11cm. The cloths are separated by a box-of-air with 4cm thick, partially filled with insulation in plates - extruded expanded polystyrene - with 4cm thick and fixed to the inner cloth. The interior vestment is coated with traditional plaster with thickness of 2cm.</p>
PExt 14		<p>Double wall with an exterior cloth in masonry of mass brick of 11cm and an interior cloth in masonry of bored brick of 15cm. The cloths are separated by a box-of-air with 4cm thick, partially filled with insulation in plates - extruded expanded polystyrene - with 4cm thick and fixed to the inner cloth. The interior vestment is coated with traditional plaster with thickness of 2cm.</p>
PExt 15		<p>Double wall with an exterior cloth in masonry of mass brick of 11cm and an interior cloth in masonry of bored brick of 11cm. The cloths are separated by a box-of-air with 4cm thick, totally filled with insulation in plates - extruded expanded polystyrene - with 4cm thick and fixed to the inner cloth. The interior vestment is coated with traditional plaster with thickness of 2cm.</p>

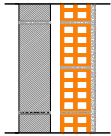
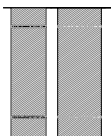
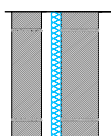
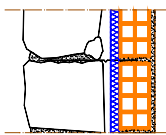
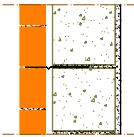
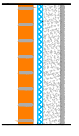
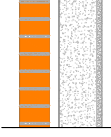
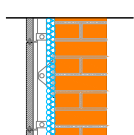
Element ID	Schematic section	Description
PExt 16		Double wall with an exterior cloth in stone masonry of 12cm and an interior cloth in masonry of bored brick of 11cm. The cloths are separated by a box-of-air with 4cm thick. The interior vestment is coated with traditional plaster with thickness of 2cm.
PExt 17		Double wall with an exterior cloth in stone masonry of 12cm and an interior cloth in stone masonry of 15cm. The cloths are separated by a box-of-air with 4cm thick.
PExt 18		Double wall with an exterior cloth in stone masonry of 12cm and an interior cloth in stone masonry of 15cm. The cloths are separated by a box-of-air with 6cm thick, partially filled with 4cm of extruded expanded polystyrene fixed to the inner cloth.
PExt 19		Double wall with an exterior cloth in masonry of granite stone with 30cm thick and an interior cloth in masonry of cast brick of 11cm. The cloths are separated by a box-of-air with 5cm thick, partially filled with insulation in plates of extruded expanded polystyrene with 3cm thick and fixed to the inner cloth. The interior vestment is coated with traditional plaster with thickness of 1.5cm.
PExt 20		Double wall with an exterior cloth in masonry of mass brick with 7cm thick and interior cloth in blocks of autoclaved aerated concrete with 17.5cm thick. The two cloths are separated by a box-of-air with 2cm thick.
PExt 21		Double wall with an exterior cloth in masonry of mass brick with 11cm thick and an interior cloth in reinforced concrete of 15cm. The cloths are separated by a box-of-air with 4cm thick, partially filled with insulation in plates - extruded expanded polystyrene - with 4cm thick and fixed to the inner cloth. The interior vestment is coated with traditional plaster with thickness of 2cm.
PExt 22		Double wall with an exterior cloth in masonry of mass brick with 11cm thick and an interior cloth in reinforced concrete of 15cm. The cloths are separated by a box-of-air with 4cm thick. The interior vestment is coated with traditional plaster with thickness of 2cm.
PExt 23		Ventilated façade with support element in masonry of mass brick of 22cm thick. On the outer surface of the support element rests an insulating layer made of extruded expanded polystyrene with 4cm thick. The outer shell is composed of stone plates of 3cm thick which are fixed to the support element by a metallic structure. The box-of-air has 6cm of thickness.

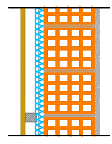
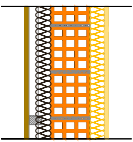
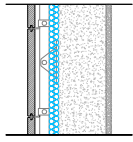
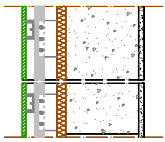
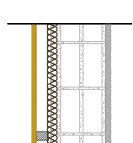
Element ID	Schematic section	Description
PExt 24		<p>Ventilated façade with support element in masonry of bored brick of 22cm thick. On the outer surface of the support element rests an insulating layer made of extruded expanded polystyrene with 4cm thick. The outer shell is composed of agglomerate plates of wood and concrete of 1.2cm thick which are fixed to the support element by a metallic structure. The box-of-air has 5cm of thickness.</p>
PExt 25		<p>Ventilated façade with support element in masonry of bored brick of 15cm. The outer shell is in agglomerate plates of wood and concrete with 1.2cm thick fixed in a metallic structure. The support element and the outer shell are separated by a box-of-air with 4cm thick, partially filled with insulation in plates - black agglomerate of cork - with 5cm thick. The inner liner is in plasterboards with 1.2cm thick fixed in metallic structure. The support element and the inner liner are separated by a box-of-air with 4cm thick, fully filled with insulation in plates - rock wool - with 5cm thick.</p>
PExt 26		<p>Ventilated façade with support element in reinforced concrete with 20cm of thickness. On the outer surface of the support element is fixed the insulating layer in extruded expanded polystyrene with 4cm thick. The outer shell is composed of stone plates of 3cm thick which are fixed to the support element by a metallic structure. The box-of-air has 6cm of thickness.</p>
PExt 27		<p>Ventilated façade with support element in masonry of lightweight concrete blocks with aggregates of expanded clay with 20cm thick. On the outer surface of the support element lies the insulating layer in black agglomerate of cork with 2.5cm thickness. The coating is composed of ceramic pieces with 1cm thick which are fixed to the support element by a metallic structure.</p>
PExt 28		<p>Ventilated façade with support element in masonry of bored concrete blocks with 20cm thick. On the outer surface of the support element lies the discontinuous insulating layer in black agglomerate of cork with 5cm thickness. The coating is composed of agglomerate plates of wood and concrete with 1.2cm thick which are fixed to the support element by a metallic structure. The box-of-air has 4cm of thickness.</p>

AI.3 Interior Walls

The following tables present the description of 22 building elements for interior walls.

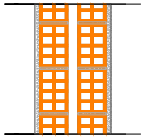
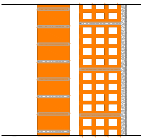
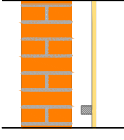
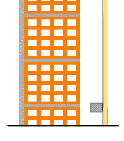
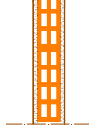
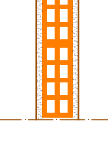
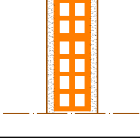
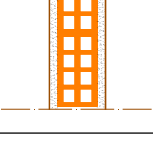
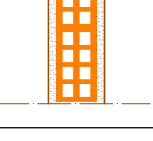

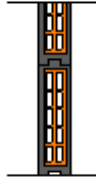
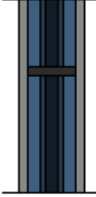
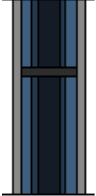
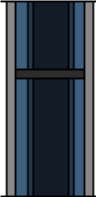
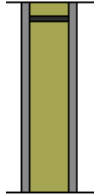
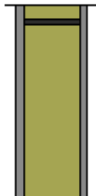
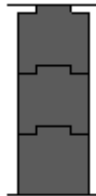

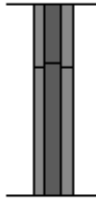
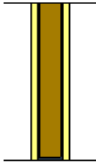
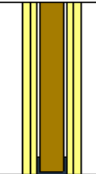
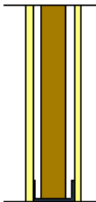
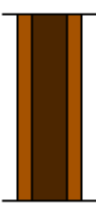
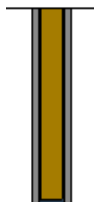
Element ID	Schematic section	Description
Plnt 1		Double wall with a drilled brick masonry exterior cloth with 11cm and a drilled brick masonry interior cloth with 11cm. The cloths are separated by a 4cm thick air gap. The interior and exterior vestments are coated with traditional plaster 2cm thick.
Plnt 2		Double wall with a solid brick masonry exterior cloth with 11cm and a drilled brick masonry interior cloth with 15cm. The cloths are separated by a 4cm thick air gap. The interior vestment is coated with traditional plaster 2cm thick.
Plnt 3		Single wall with a solid brick masonry support element of 22cm. The support member is separated from the inner coating by an air gap with 9cm thickness. The inner coating is composed by plasterboards with 1.2cm thick.
Plnt 4		Single wall with a drilled brick masonry support element of 22cm. the exterior cloth is separated from the inner coating by a 9cm air gap. The inner coating is composed by plasterboards with 1.2cm thick. The exterior cloth is coated with traditional plaster 2cm thick (Martins, 2005).
Plnt 5		Drilled brick masonry single wall with 7cm thick. The vestments, interior and exterior are coated with traditional plaster 1.5cm thick.
Plnt 6		Drilled brick masonry single wall with 9cm thick. The vestments, interior and exterior are coated with traditional plaster 1.5cm thick.
Plnt 7		Drilled brick masonry single wall with 11cm thick. The vestments, interior and exterior are coated with traditional plaster 1.5cm thick.
Plnt 8		Drilled brick masonry single wall with 15cm thick. The vestments, interior and exterior are coated with traditional plaster 1.5cm thick.
Plnt 9		Drilled brick masonry single wall with 22cm thick. The vestments, interior and exterior are coated with traditional plaster 1.5cm thick.





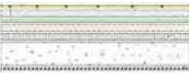

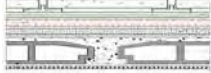
Element ID	Schematic section	Description
Plnt 10		<p>Single wall composed by hollow brick masonry with the dimensions of 81*33*6cm, coated on both sides with traditional plaster of 1cm.</p>
Plnt 11		<p>Lightweight concrete masonry blocks single wall with 8cm thick, coated on both sides with 1.5cm of traditional plaster. These blocks have a weight per unit of 6kg.</p>
Plnt 12		<p>Lightweight concrete masonry blocks single wall with 10cm thick, coated on both sides with 1.5cm of traditional plaster. These blocks have a weight per unit of 8kg.</p>
Plnt 13		<p>Lightweight concrete masonry blocks single wall with 12cm thick, coated on both sides with 1.5cm of traditional plaster. These blocks have a weight per unit of 10kg.</p>
Plnt 14		<p>Autoclaved concrete masonry blocks single wall with 7.5cm thick, coated on both sides with 1.5cm of traditional plaster.</p>
Plnt 15		<p>Autoclaved concrete masonry blocks single wall with 10cm thick, coated on both sides with 1.5cm of traditional plaster.</p>
Plnt 16		<p>Lightweight interlocked masonry blocks single wall with the dimensions of 25*12.5*12.5cm.</p>



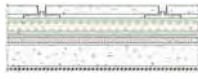

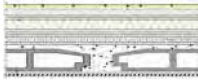
Element ID	Schematic section	Description
Plnt 17		Single wall composed by prefabricated plaster blocks with nominal dimensions of 50*66.7*7cm.
Plnt 18		System of prefabricated plasterboard panels, with profiles of galvanized steel and rock wool insulation. The wall has a thickness of 72mm, where 40mm are for rock wool and 13mm for each one of the plasterboards. The metal profiles that constitute the internal structure of the system may be separated by 400 or 600mm.
Plnt 19		System consisting of an internal structure of metallic profiles to which are fixed, on each side, two layers of plasterboards. The cavity between the two vestments is filled with rock wool 4 mm thick.
Plnt 20		System comprising metallic profiles of galvanized steel, plasterboards, on each side, with a thickness of 15mm and rock wool insulation in the cavity with a density of 40kg/m ³ . On both sides, between the rock wool and the plasterboards, there is an air gap of 14.5mm.
Plnt 21		Freestanding system comprising MDF boards (wood fiber board of medium density) and a wooden structure, having a total thickness of 25mm.
Plnt 22		System consisting of profiles of galvanized steel plate with 48mm high, coated on both sides with panels of chipboard wood and concrete of 12mm thickness. The cavity is partially filled with a blanket of rock wool 40mm thick.



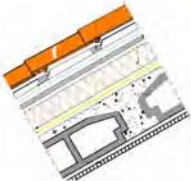

AI.4 Roofs

The following tables present the description of 23 alternative building elements for roofs.

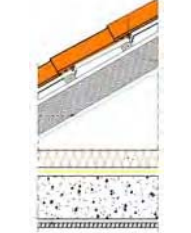
Element ID	Schematic section	Description
Cob 1		<p>Traditional flat roof with exterior coating in cobble, with 10cm thick and inner coating in traditional plaster of 2cm thick. The support is in solid slab with a thickness of 20cm, upon which rests: the layer of lightweight concrete form with 10cm thick; the PVC vapour barrier; the thermal insulation in plates of expanded polystyrene (EPS) with 8cm thick; the layer of waterproofing in PVC membranes; the blanket of geotextile, and finally, the ceramic mosaic.</p>
Cob 2		<p>Traditional flat roof with exterior coating in ceramic mosaic and inner coating in traditional plaster of 2cm thick. The support is in solid slab with a thickness of 20cm, upon which rests: the layer of lightweight concrete form with 10cm thick; the PVC vapour barrier; the thermal insulation in plates of expanded polystyrene (EPS) with 8cm thick; the layer of waterproofing in PVC membranes; a layer of laying in reinforced concrete with 6 cm thick, and finally, the ceramic mosaic.</p>
Cob 3		<p>Traditional flat roof with exterior coating in concrete slabs (supported by spacers) and inner coating in traditional plaster of 2cm thick. The support is in lightweight slab of 24cm of thickness with ceramic cap vaults, upon which rests: the layer of lightweight concrete form with 10cm thick; the PVC vapour barrier; the thermal insulation in plates of expanded polystyrene (EPS) with 8cm thick; the layer of waterproofing in PVC membranes; and finally, the concrete slabs.</p>
Cob 4		<p>Traditional flat roof with exterior coating in concrete slabs (supported by spacers) and inner coating in traditional plaster of 2cm thick. The support is in lightweight slab of 24cm of thickness with normal blocks upon which rests: the layer of lightweight concrete form with 10cm thick; the PVC vapour barrier; the thermal insulation in plates of expanded polystyrene (EPS) with 8cm thick; the layer of waterproofing in PVC membranes; and finally, the concrete slabs.</p>
Cob 5		<p>Traditional flat roof with exterior coating in concrete slabs (supported by spacers) and inner coating in traditional plaster of 2cm thick. The support is in lightweight slab of 24cm of thickness with lightweight concrete blocks (with expanded clay aggregates) upon which rests: the layer of lightweight concrete form with 10cm thick; the PVC vapour barrier; the thermal insulation in plates of expanded polystyrene (EPS) with 8cm thick; the layer of waterproofing in PVC membranes; and finally, the concrete slabs.</p>
Cob 6		<p>Inverted flat roof with exterior coating in cobble, with 10cm thick and inner coating in traditional plaster of 2cm thick. The support of this solution is a solid slab of 20cm thick which rests: the layer of lightweight concrete form with 10cm thick; the layer of waterproofing in bituminous membranes; a felt separator in synthetic fibbers; the thermal insulation in plates of extruded expanded polystyrene (XPS) with 8cm thick; the blanket of geotextile; and finally, the heavy protection (cobble).</p>

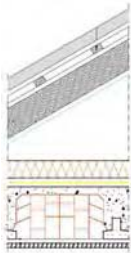

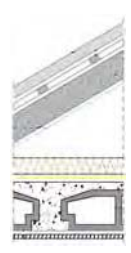

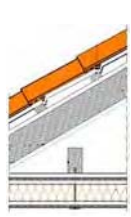
Element ID	Schematic section	Description
Cob 7		<p>Inverted flat roof with exterior coating in concrete slabs and inner coating in traditional plaster of 2cm thick. The support of this solution is a solid slab of 20cm thick which rests: the layer of lightweight concrete form with 10cm thick; the layer of waterproofing in bituminous membranes; a felt separator in synthetic fibbers; the thermal insulation in plates of extruded expanded polystyrene (XPS) with 8cm thick; the blanket of geotextile; and finally, the heavy protection (cobble).</p>
Cob 8		<p>Inverted flat roof with exterior coating in armed screed, with 6cm thick and inner coating in traditional plaster of 2cm thick. The support of this solution is a lightweight slab of 24cm with ceramic vaulted which rests: the layer of lightweight concrete form with 10cm thick; the layer of waterproofing in bituminous membranes; a felt separator in synthetic fibbers; the thermal insulation in plates of extruded expanded polystyrene (XPS) with 8cm thick; and finally, the armed screed.</p>
Cob 9		<p>Inverted flat roof with exterior coating in ceramic mosaic thick and inner coating in traditional plaster of 2cm. The support of this solution is a lightweight slab of 24cm with normal concrete blocks, which rests: the layer of lightweight concrete form with 10cm thick; the layer of waterproofing in bituminous membranes; a felt separator in synthetic fibbers; the thermal insulation in plates of extruded expanded polystyrene (XPS) with 8cm thick; a layer of laying in reinforced concrete with 6cm thick; and finally, the ceramic mosaic.</p>
Cob 10		<p>Inverted flat roof with exterior coating in ceramic mosaic and inner coating in traditional plaster of 2cm. The support is in lightweight slab of 24cm with lightweight concrete blocks upon which rests: the layer of lightweight concrete form with 10cm thick; the layer of waterproofing in bituminous membranes; a felt separator in synthetic fibbers; the thermal insulation in plates of extruded expanded polystyrene (XPS) with 8cm thick; a layer of laying in reinforced concrete with 6cm thick; and finally, the ceramic mosaic.</p>
Cob 11		<p>Landscaped roof with topsoil layer with 20cm thick and inner coating in traditional plaster of 2cm. The support of this solution is a solid slab in reinforced concrete with 20cm thick, which rests: the layer of lightweight concrete form with 5cm thick; the layer of waterproofing in bituminous membranes with anti-roots additive; felt separator in synthetic fibbers; the thermal insulation in plates of extruded expanded polystyrene (XPS) with 8cm thick; felt separator in synthetic fibbers; drainage layer in gravel with 10cm of thickness; felt separator in synthetic fibbers; and finally, the topsoil.</p>
Cob 12		<p>Sloping roof with wooden structure (ripped with a section of 5x3cm and sticks with a section of 8x12cm) that serve as support to the outer coating in ceramic tile. Thermal insulation is in extruded expanded polystyrene and has a thickness of 8cm. Under the thermal insulation there is a vapour barrier in PVC membranes. The interior is in gypsum plasterboard of 1.25cm thick.</p>





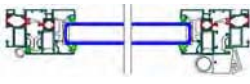

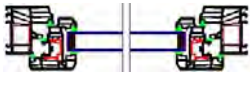
Element ID	Schematic section	Description
Cob 13		<p>Sloping roof with exterior coating in ceramic tile and inner coating in traditional plaster of 2cm thick. The support of this solution is a solid slab in reinforced concrete with 20cm thick, which rests: a vapour barrier in PVC membranes; the thermal insulation is in plates of extruded expanded polystyrene and has a thickness of 8cm; counter ripped with section of 5x3cm; ripped with section of 5x3cm; and finally, the ceramic tile.</p>
Cob 14		<p>Sloping roof with exterior coating in ceramic tile and inner coating in traditional plaster of 2cm thick. The support of this solution is a lightweight slab with 24cm thick and lightening material of ceramic, which rests: a vapour barrier in PVC membranes; the thermal insulation is in plates of extruded expanded polystyrene and has a thickness of 8cm; counter ripped with section of 5x3cm; ripped with section of 5x3cm; and finally, the ceramic tile.</p>
Cob 15		<p>Sloping roof with exterior coating in ceramic tile and inner coating in traditional plaster of 2cm thick. The support of this solution is a lightweight slab with 24cm thick and lightening material in normal concrete, which rests: a vapour barrier in PVC membranes; the thermal insulation is in plates of extruded expanded polystyrene with 8cm thick; counter ripped with section of 5x3cm; ripped with section of 5x3cm; and finally, the ceramic tile.</p>
Cob 16		<p>Sloping roof with exterior coating in ceramic tile and inner coating in traditional plaster of 2cm thick. The support of this solution is a lightweight slab with 24cm thick and lightening material in lightweight concrete, which rests: a vapour barrier in PVC membranes; the thermal insulation is in plates of extruded expanded polystyrene with 8cm thick; counter ripped with section of 5x3cm; ripped with section of 5x3cm; and finally, the ceramic tile.</p>
Cob 17		<p>Sloping roof with wooden structure (ripped with a section of 5x3cm and sticks with a section of 8x12cm) that serve as support to the exterior coating in ceramic tile. The inner liner is formed of a sandwich panel with faces made up of panels of Oriented Strand Board (OSB), with 1cm thickness, and cavity filled with extruded expanded polystyrene with 8cm thick.</p>
Cob 18		<p>It has a discontinuous structure in wood (ripped with a section of 5x3cm and sticks with a section of 8x12cm) that serve as support to the exterior coating in ceramic tile. The thermal insulation, that is in extruded expanded polystyrene (XPS) with 8cm thick, is located on the horizontal slab. The support is a solid slab with 20cm, coated on the underside with traditional plaster. On the solid slab there is a vapour barrier in PVC membranes.</p>

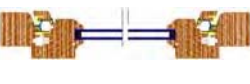



Element ID	Schematic section	Description
Cob 19		<p>It has a discontinuous structure in wood (ripped with a section of 5x3cm and sticks with a section of 8x12cm) that serve as support to the exterior coating in fiber cement sheet. The thermal insulation, which is in extruded expanded polystyrene with 6cm thick, is located on the horizontal slab. The support is a lightweight slab of 24cm thick with lightening in ceramic vaulted. The inner liner is the traditional plaster with 2cm thick. On the solid slab there is a vapour barrier in PVC membranes.</p>
Cob 20		<p>It has a discontinuous structure in wood (ripped with a section of 5x3cm and sticks with a section of 8x12cm) that serve as support to the exterior coating in fiber cement sheet. The thermal insulation, which is in extruded expanded polystyrene with 8cm thick, is located on the horizontal slab. The support is a lightweight slab of 24cm thick with lightening in normal concrete blocks. The inner liner is the traditional plaster with 2cm thick. On the solid slab there is a vapour barrier in PVC membranes.</p>
Cob 21		<p>It has a discontinuous structure in wood (ripped with a section of 5x3cm and sticks with a section of 8x12 cm) that serve as support to the exterior coating in fiber cement sheet. The thermal insulation, which is in extruded expanded polystyrene with 8cm thick, is located on the horizontal slab. The support is a lightweight slab of 24cm thick with lightening in lightweight concrete blocks. The inner liner is the traditional plaster with 2cm thick. On the solid slab there is a vapour barrier in PVC membranes.</p>
Cob 22		<p>It has a discontinuous structure in wood (ripped with a section of 5x3cm and sticks with a section of 8x12 cm) that serve as support to the exterior coating in fiber cement sheet. The isolation, in rock wool with 10 cm thick, is laid on the horizontal belt. The belt is composed of support elements in wood with 8x12cm of section and the ceiling is covered with gypsum plasterboards. On the gypsum plasterboards there is a vapour barrier in PVC membranes.</p>
Cob 23		<p>It has a discontinuous structure in wood (ripped with a section of 5x3cm and sticks with a section of 8x12cm) that serve as support to the exterior coating in ceramic tile. The horizontal belt is composed of support elements in wood with 8x12cm of section and the ceiling is covered with a sandwich panel with faces made up of panels of Oriented Strand Board (OSB), with 1cm thickness, and cavity filled with extruded expanded polystyrene with 8cm thick.</p>

AI.5 Windows

The following tables present the description of 18 alternative building elements for glazed areas.

Element ID	Schematic section	Description
Env 1		<p>It is composed by a system of aluminium frameworks with 3 chambers and has a sheet with a constructive depth of 60mm and a ring with 52mm. The thermal cut is provided by double ethylene propylene diene monomer (EPDM) rubber "barrettes", and the metal separation has 9mm. It is equipped with a double glazing, composed by an outer glass with 4mm, an air gap with 22mm and an inner glass with 4mm.</p>
Env 2		<p>It is composed by a system of aluminium frameworks with 3 chambers and has a sheet with a constructive depth of 60mm and a ring with 52mm. The thermal cut is provided by double ethylene propylene diene monomer (EPDM) rubber "barrettes", and the metal separation has 9mm. It is equipped with a double glazing, composed by an outer glass with 4mm, an air gap with 16mm and an inner glass with 10mm.</p>
Env 3		<p>It is composed by a system of aluminium frameworks with 3 chambers and has a sheet with a constructive depth of 60mm and a ring with 52mm. The thermal cut is provided by double ethylene-propylene-dyne (EPDM) rubber "barrettes", and the metal separation has 9mm. It is equipped with a double glazing, composed by an outer glass with 4mm, an air gap with 14mm and an inner glass with 8mm.</p>
Env 4		<p>It is composed by a PVC window frame system with 5 chambers, has a sheet with a constructive depth of 79mm and a ring with 72mm. It is equipped with a double glazing, composed by an outer glass with 4mm, an air gap with 22mm and an inner glass 4mm.</p>
Env 5		<p>It is composed by a PVC window frame system with 5 chambers, has a sheet with a constructive depth of 79mm and a ring with 72mm. It is equipped with a double glazing, composed by an outer glass with 4mm, an air gap with 16mm and an inner glass 16mm.</p>
Env 6		<p>It is composed by a PVC window frame system with 5 chambers, has a sheet with a constructive depth of 79mm and a ring with 72mm. It is equipped with a double glazing, composed by an outer glass with 8mm, an air gap with 14mm and an inner glass 8mm</p>
Env 7		<p>It is composed by a window frame system with solid or laminated wood profile, has a sheet with a constructive depth of 68mm and a ring with 58mm. It is equipped with a double glazing, composed by an outer glass with 4mm, an air gap with 10mm and an inner glass with 4mm.</p>

Element ID	Schematic section	Description
Env 8		<p>It is composed by a window frame system with solid or laminated wood profile, has a sheet with a constructive depth of 68mm and a ring with 58mm. It is equipped with a double glazing, composed by an outer glass with 4mm, an air gap with 6mm and an inner glass with 10mm.</p>
Env 9		<p>It is composed by a window frame system with solid or laminated wood profile, has a sheet with a constructive depth of 68mm and a ring with 58mm. It is equipped with a double glazing, composed by an outer glass with 8mm, an air gap with 6mm and an inner glass with 8mm.</p>
Env 10		<p>It is composed by a wooden window frame system with an aluminium exterior rounded capping. It has a sheet with a total depth of 90mm, of which 65mm are made of wood, and a ring with 85mm in total, of which 65mm are made of wood. It is equipped with a double glazing, composed by an outer glass with 4mm, an air gap with 10mm and an inner glass with 4mm.</p>
Env 11		<p>It is composed by a wooden window frame system with an aluminium exterior rounded capping. It has a sheet with a total depth of 90mm, of which 65mm are made of wood, and a ring with 85mm in total, of which 65mm are made of wood. It is equipped with a double glazing, composed by an outer glass with 4mm, an air gap with 6mm and an inner glass with 10mm.</p>
Env 12		<p>It is composed by a wooden window frame system with an aluminium exterior rounded capping. It has a sheet with a total depth of 90mm, of which 65mm are made of wood, and a ring with 85mm in total, of which 65mm are made of wood. It is equipped with a double glazing, composed by an outer glass with 8mm, an air gap with 6mm and an inner glass with 8mm.</p>
Env 13		<p>It is composed by a PVC window frame system with wooden overturning in the interior. This system has 5 chambers, a sheet with a depth of 76mm and a ring with 84mm. Is equipped with a double glazing, composed by an outer glass with 4mm, an air gap with 22mm and an inner glass with 4mm.</p>
Env 14		<p>It is composed by a PVC window frame system with wooden overturning in the interior. This system has 5 chambers, a sheet with a depth of 76mm and a ring with 84mm. Is equipped with a double glazing, composed by an outer glass with 4mm, an air gap with 6mm and an inner glass with 10mm.</p>

Element ID	Schematic section	Description
Env 15		<p>It is composed by a PVC window frame system with wooden overturning in the interior. This system has 5 chambers, a sheet with a depth of 76mm and a ring with 84mm. Is equipped with a double glazing, composed by an outer glass with 8mm, an air gap with 6mm and an inner glass with 8mm.</p>
Env 16		<p>It is composed by a PVC window frame system and is coated with aluminium outside. This system has 5 chambers, a sheet with a depth of 82mm and a ring with 80mm. Is equipped with a double glazing, composed by an outer glass with 4mm, an air gap with 22mm and an inner glass with 4mm.</p>
Env 17		<p>It is composed by a PVC window frame system and is coated with aluminium outside. This system has 5 chambers, a sheet with a depth of 82mm and a ring with 80mm. Is equipped with a double glazing, composed by an outer glass with 4mm, an air gap with 16mm and an inner glass with 10mm.</p>
Env 18		<p>It is composed by a PVC window frame system and is coated with aluminium outside. This system has 5 chambers, a sheet with a depth of 82mm and a ring with 80mm. Is equipped with a double glazing, composed by an outer glass with 8mm, an air gap with 14mm and an inner glass with 8mm.</p>

ANNEX II

LCA DATABASE

All.1 Floors

The following pages present the results from the quantification of environmental impact categories of 16 building elements for pavements floor. The meaning of the acronyms used in these pages, as well as the unit that express each of the environmental impact categories are shown in Table 6 of this book.

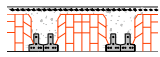
Building element	Lightened pavement of prestressed beams and ceramic blocks of formwork without thermal insulation								Ref: Pav 1
Life-cycle phase	Environmental LCA impact categories						Embodied energy		
	ADP	GWP	ODP	AP	POCP	EP	ENR	ER	
 Cradle-to-gate	2,46E-01	5,89E+01	2,61E-06	1,29E-01	1,05E-02	2,06E-02	5,13E+02	2,47E+01	
End of life	1,98E-01	2,89E+01	4,67E-06	1,37E-01	5,20E-03	2,84E-02	4,56E+02	2,64E+00	
Total	4,44E-01	8,78E+01	7,28E-06	2,66E-01	1,57E-02	4,90E-02	9,69E+02	2,73E+01	
<p>Comments: Considered Materials: concrete, steel (includes reinforcement in beams, reinforcement of distribution, on the supports and on billets) and ceramic blocks</p> <p>LCA Method(s): CML 2 baseline 2000 version 2.04 (to assess the environmental impact) and Cumulative Energy Demand version 1.04 (to assess the energy)</p> <p>LCI Libraries: Ecoinvent system process and ETH-ESU 96 system process</p>									

Building element	Lightened pavement of prestressed beams and ceramic blocks of formwork with false ceiling and thermal insulation in masonry								Ref: Pav 2
Life-cycle phase	Environmental LCA impact categories						Embodied energy		
	ADP	GWP	ODP	AP	POCP	EP	ENR	ER	
 Cradle-to-gate	2,84E-01	6,43E+01	3,11E-06	1,49E-01	1,15E-02	2,34E-02	6,00E+02	2,93E+01	
End of life	3,04E-01	4,47E+01	6,67E-06	2,57E-01	8,20E-03	5,40E-02	6,93E+02	3,53E+00	
Total	5,88E-01	1,09E+02	9,78E-06	4,06E-01	1,97E-02	7,74E-02	1,29E+03	3,28E+01	
<p>Comments: Considered Materials: concrete, steel (includes reinforcement in beams, reinforcement of distribution, on the supports and on billets) and ceramic blocks, plasterboard panel and rock wool blanket</p> <p>LCA Method(s): CML 2 baseline 2000 version 2.04 (to assess the environmental impact) and Cumulative Energy Demand version 1.04 (to assess the energy)</p> <p>LCI Libraries: Ecoinvent system process and ETH-ESU 96 system process</p>									

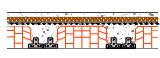
Building element	Lightened pavement of prestressed beams and ceramic blocks of formwork with false ceiling, thermal insulation and floating slab								Ref: Pav 3
Life-cycle phase	Environmental LCA impact categories						Embodied energy		
	ADP	GWP	ODP	AP	POCP	EP	ENR	ER	
 Cradle-to-gate	4,10E-01	7,37E+01	4,75E-06	2,64E-01	1,75E-02	3,22E-02	8,94E+02	1,87E+02	
End of life	2,22E-01	3,23E+01	5,25E-06	1,54E-01	5,80E-03	3,19E-02	5,16E+02	2,55E+00	
Total	6,32E-01	1,06E+02	1,00E-05	4,18E-01	2,33E-02	6,41E-02	1,41E+03	1,90E+02	
<p>Comments: Considered Materials: concrete, steel (includes reinforcement in beams, reinforcement of distribution, on the supports and on billets) and ceramic blocks, plasterboard panel, rock wool blanket, polyethylene foam, black cork agglomerate and floating slab.</p> <p>LCA Method(s): CML 2 baseline 2000 version 2.04 (to assess the environmental impact) and Cumulative Energy Demand version 1.04 (to assess the energy)</p> <p>LCI Libraries: Ecoinvent system process and ETH-ESU 96 system process</p>									

Building element	Continuous structure pavement in solid slab of reinforced concrete and without thermal insulation								Ref: Pav 4
Life-cycle phase	Environmental LCA impact categories						Embodied energy		
	ADP	GWP	ODP	AP	POCP	EP	ENR	ER	
 Cradle-to-gate	2,52E-01	6,90E+01	2,31E-06	1,42E-01	1,19E-02	2,50E-02	5,13E+02	8,76E+00	
End of life	2,74E-01	4,00E+01	6,40E-06	1,90E-01	7,10E-03	3,94E-02	6,32E+02	3,78E+00	
Total	5,26E-01	1,09E+02	8,71E-06	3,32E-01	1,90E-02	6,44E-02	1,14E+03	1,25E+01	
<p>Comments: Considered Materials: concrete and steel (includes main reinforcement, reinforcement of distribution and support)</p> <p>LCA Method(s): CML 2 baseline 2000 version 2.04 (to assess the environmental impact) and Cumulative Energy Demand version 1.04 (to assess the energy)</p> <p>LCI Libraries: Ecoinvent system process and ETH-ESU 96 system process</p>									

Building element	Continuous structure pavement in solid slab of reinforced concrete, with false ceiling and thermal insulation in masonry								Ref: Pav 5
Life-cycle phase	Environmental LCA impact categories						Embodied energy		
	ADP	GWP	ODP	AP	POCP	EP	ENR	ER	
Cradle-to-gate	2,90E-01	7,44E+01	2,81E-06	1,62E-01	1,29E-02	2,79E-02	5,99E+02	1,34E+01	
End of life	2,80E-01	4,06E+01	6,52E-06	1,94E-01	7,20E-03	4,01E-02	6,38E+02	3,85E+00	
Total	5,70E-01	1,15E+02	9,33E-06	3,56E-01	2,01E-02	6,80E-02	1,24E+03	1,72E+01	
<p>Comments: Considered Materials: concrete, steel (includes main reinforcement, reinforcement of distribution and support), plasterboard panel and rock wool blanket</p> <p>LCA Method(s): CML 2 baseline 2000 version 2.04 (to assess the environmental impact) and Cumulative Energy Demand version 1.04 (to assess the energy)</p> <p>LCI Libraries: Ecoinvent system process and ETH-ESU 96 system process</p>									

Building element	Continuous structure pavement in solid slab of reinforced concrete, with false ceiling, thermal insulation and floating slab								Ref: Pav 6
Life-cycle phase	Environmental LCA impact categories						Embodied energy		
	ADP	GWP	ODP	AP	POCP	EP	ENR	ER	
Cradle-to-gate	4,15E-01	8,38E+01	4,45E-06	2,77E-01	1,89E-02	3,66E-02	8,93E+02	1,71E+02	
End of life	2,99E-01	4,32E+01	6,95E-06	2,07E-01	7,70E-03	4,29E-02	6,86E+02	3,59E+00	
Total	7,14E-01	1,27E+02	1,14E-05	4,84E-01	2,66E-02	7,95E-02	1,58E+03	1,75E+02	
<p>Comments: Considered Materials: concrete, steel (includes main reinforcement, reinforcement of distribution and support), plasterboard panel, rock wool blanket, polyethylene foam, black cork agglomerate and floating slab.</p> <p>LCA Method(s): CML 2 baseline 2000 version 2.04 (to assess the environmental impact) and Cumulative Energy Demand version 1.04 (to assess the energy)</p> <p>LCI Libraries: Ecoinvent system process and ETH-ESU 96 system process</p>									

Building element	Pavement composed by alveolar panels without thermal insulation								Ref: Pav 7
Life-cycle phase	Environmental LCA impact categories						Embodied energy		
	ADP	GWP	ODP	AP	POCP	EP	ENR	ER	
Cradle-to-gate	1,76E-01	5,11E+01	1,70E-06	1,02E-01	8,07E-03	1,78E-02	3,64E+02	6,02E+00	
End of life	2,11E-01	3,04E+01	4,92E-06	1,46E-01	5,43E-03	3,03E-02	4,85E+02	2,91E+00	
Total	3,87E-01	8,15E+01	6,62E-06	2,48E-01	1,35E-02	4,81E-02	8,49E+02	8,93E+00	
<p>Comments: Considered Materials: concrete (includes concrete in the panels, complementary concrete and in the solidarity joints) and steel (includes reinforcement in panels and reinforcement of distribution).</p> <p>LCA Method(s): CML 2 baseline 2000 version 2.04 (to assess the environmental impact) and Cumulative Energy Demand version 1.04 (to assess the energy)</p> <p>LCI Libraries: Ecoinvent system process and ETH-ESU 96 system process</p>									

Building element	Pavement composed by alveolar panels with false ceiling and thermal insulation								Ref: Pav 8
Life-cycle phase	Environmental LCA impact categories						Embodied energy		
	ADP	GWP	ODP	AP	POCP	EP	ENR	ER	
Cradle-to-gate	2,15E-01	5,65E+01	2,20E-06	1,23E-01	9,04E-03	2,07E-02	4,50E+02	1,06E+01	
End of life	2,16E-01	3,13E+01	5,05E-06	1,49E-01	5,56E-03	3,10E-02	4,97E+02	2,98E+00	
Total	4,31E-01	8,78E+01	7,25E-06	2,72E-01	1,46E-02	5,17E-02	9,47E+02	1,36E+01	
<p>Comments: Considered Materials: concrete (includes concrete in the panels, complementary concrete and in the solidarity joints), steel (includes reinforcement in panels and reinforcement of distribution), plasterboard panel and rock wool blanket.</p> <p>LCA Method(s): CML 2 baseline 2000 version 2.04 (to assess the environmental impact) and Cumulative Energy Demand version 1.04 (to assess the energy)</p> <p>LCI Libraries: Ecoinvent system process and ETH-ESU 96 system process</p>									

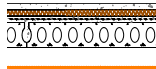
Building element	Pavement composed by alveolar panels with false ceiling, thermal insulation and floating slab								Ref: Pav 9
	Life-cycle phase	Environmental LCA impact categories						Embodied energy	
		ADP	GWP	ODP	AP	POCP	EP	ENR	ER
	Cradle-to-gate	3,40E-01	6,60E+01	3,84E-06	2,37E-01	1,51E-02	2,94E-02	7,44E+02	1,68E+02
	End of life	2,36E-01	3,40E+01	5,50E-06	1,63E-01	6,00E-03	3,38E-02	5,40E+02	3,82E+00
	Total	5,76E-01	1,00E+02	9,34E-06	4,00E-01	2,11E-02	6,32E-02	1,28E+03	1,72E+02
Comments:		<p>Considered Materials: concrete (includes concrete in the panels, complementary concrete and in the solidarity joints), steel (includes reinforcement in panels and reinforcement of distribution), plasterboard panel, rock wool blanket, polyethylene foam, black cork agglomerate and floating slab.</p> <p>LCA Method(s): CML 2 baseline 2000 version 2.04 (to assess the environmental impact) and Cumulative Energy Demand version 1.04 (to assess the energy)</p> <p>LCI Libraries: Ecoinvent system process and ETH-ESU 96 system process</p>							

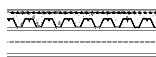
Building element	Mixed pavement in cooperating metal formwork and without thermal insulation								Ref: Pav 10
	Life-cycle phase	Environmental LCA impact categories						Embodied energy	
		ADP	GWP	ODP	AP	POCP	EP	ENR	ER
	Cradle-to-gate	3,84E-01	5,79E+01	2,10E-06	1,69E-01	2,32E-02	3,31E-02	7,08E+02	1,55E+01
	End of life	1,02E-01	1,48E+01	2,39E-06	7,00E-02	2,70E-03	1,46E-02	2,35E+02	1,37E+00
	Total	4,86E-01	7,27E+01	4,49E-06	2,39E-01	2,59E-02	4,77E-02	9,42E+02	1,69E+01
Comments:		<p>Considered Materials: concrete and steel (including steel panels, rolled profiles and reinforcement of distribution).</p> <p>LCA Method(s): CML 2 baseline 2000 version 2.04 (to assess the environmental impact) and Cumulative Energy Demand version 1.04 (to assess the energy)</p> <p>LCI Libraries: Ecoinvent system process and ETH-ESU 96 system process</p>							

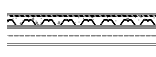
Building element	Mixed pavement in cooperating metal formwork with false ceiling and thermal insulation								Ref: Pav 11
	Life-cycle phase	Environmental LCA impact categories						Embodied energy	
		ADP	GWP	ODP	AP	POCP	EP	ENR	ER
	Cradle-to-gate	4,22E-01	6,33E+01	2,60E-06	1,89E-01	2,42E-02	3,60E-02	7,95E+02	2,01E+01
	End of life	1,07E-01	1,57E+01	2,52E-06	7,40E-02	2,80E-03	1,53E-02	2,46E+02	1,47E+00
	Total	5,29E-01	7,90E+01	5,12E-06	2,63E-01	2,70E-02	5,13E-02	1,04E+03	2,16E+01
Comments:		<p>Considered Materials: concrete, steel (including steel panels, rolled profiles and reinforcement of distribution), plasterboard panel and rock wool blanket.</p> <p>MLCA Method(s): CML 2 baseline 2000 version 2.04 (to assess the environmental impact) and Cumulative Energy Demand version 1.04 (to assess the energy)</p> <p>LCI Libraries: Ecoinvent system process and ETH-ESU 96 system process</p>							

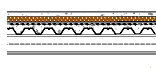
Building element	Mixed pavement in cooperating metal formwork with false ceiling, thermal insulation and floating slab								Ref: Pav 12
	Life-cycle phase	Environmental LCA impact categories						Embodied energy	
		ADP	GWP	ODP	AP	POCP	EP	ENR	ER
	Cradle-to-gate	5,48E-01	7,28E+01	4,24E-06	3,04E-01	3,02E-02	4,47E-02	1,09E+03	1,77E+02
	End of life	1,26E-01	1,84E+01	2,97E-06	8,70E-02	3,30E-03	1,81E-02	2,95E+02	2,48E+00
	Total	6,74E-01	9,12E+01	7,21E-06	3,91E-01	3,35E-02	6,28E-02	1,38E+03	1,80E+02
Comments:		<p>Considered Materials: concrete, steel (including steel panels, rolled profiles and reinforcement of distribution), plasterboard panel, rock wool blanket, polyethylene foam, black cork agglomerate and floating slab.</p> <p>LCA Method(s): CML 2 baseline 2000 version 2.04 (to assess the environmental impact) and Cumulative Energy Demand version 1.04 (to assess the energy)</p> <p>LCI Libraries: Ecoinvent system process and ETH-ESU 96 system process</p>							

Building element	Discontinuous structure Pavement in wood and without thermal insulation								Ref: Pav 13
	Life-cycle phase	Environmental LCA impact categories						Embodied energy	
		ADP	GWP	ODP	AP	POCP	EP	ENR	ER
	Cradle-to-gate	6,10E-02	-4,86E+01	8,36E-07	3,84E-02	2,66E-03	6,06E-03	1,49E+02	6,65E+02
	End of life	2,35E-02	5,73E+01	5,34E-07	2,22E-02	8,70E-04	1,35E-02	5,28E+01	3,09E-01
	Total	8,45E-02	8,68E+00	1,37E-06	6,06E-02	3,53E-03	1,96E-02	2,02E+02	6,65E+02
<p>Comments: Considered Materials: wood (wood in floating floor and beams) and plasterboards.</p> <p>LCA Method(s): CML 2 baseline 2000 version 2.04 (to assess the environmental impact) and Cumulative Energy Demand version 1.04 (to assess the energy)</p> <p>LCI Libraries: Ecoinvent system process and ETH-ESU 96 system process</p>									

Building element	Discontinuous structure pavement in wood with false ceiling and thermal insulation								Ref: Pav 14
	Life-cycle phase	Environmental LCA impact categories						Embodied energy	
		ADP	GWP	ODP	AP	POCP	EP	ENR	ER
	Cradle-to-gate	9,45E-02	-4,40E+01	1,03E-06	6,50E-02	4,09E-03	9,03E-03	2,19E+02	6,68E+02
	End of life	2,65E-02	7,89E+01	5,80E-07	2,63E-02	1,03E-03	1,80E-02	5,89E+01	3,72E-01
	Total	1,21E-01	3,49E+01	1,61E-06	9,13E-02	5,12E-03	2,70E-02	2,78E+02	6,68E+02
<p>Comments: Considered Materials: wood (wood in floating floor and beams) and plasterboards, plasterboard panel and rock wool blanket.</p> <p>LCA Method(s): CML 2 baseline 2000 version 2.04 (to assess the environmental impact) and Cumulative Energy Demand version 1.04 (to assess the energy)</p> <p>LCI Libraries: Ecoinvent system process and ETH-ESU 96 system process</p>									

Building element	Discontinuous structure pavement in wood with false ceiling, thermal insulation and floating slab over the structural coating								Ref: Pav 15
	Life-cycle phase	Environmental LCA impact categories						Embodied energy	
		ADP	GWP	ODP	AP	POCP	EP	ENR	ER
	Cradle-to-gate	8,56E-02	-4,81E+01	9,75E-07	5,60E-02	4,17E-03	8,04E-03	2,01E+02	6,98E+02
	End of life	2,54E-02	6,01E+01	5,75E-07	2,36E-02	9,30E-04	1,43E-02	5,68E+01	3,30E-01
	Total	1,11E-01	1,20E+01	1,55E-06	7,96E-02	5,10E-03	2,23E-02	2,58E+02	6,99E+02
<p>Comments: Considered Materials: wood (wood in floating floor, beams and structural sheathing) and plasterboards, plasterboard panel, rock wool blanket and polyethylene foam.</p> <p>LCA Method(s): CML 2 baseline 2000 version 2.04 (to assess the environmental impact) and Cumulative Energy Demand version 1.04 (to assess the energy)</p> <p>LCI Libraries: Ecoinvent system process and ETH-ESU 96 system process</p>									

Building element	Discontinuous structure pavement in wood with thermal insulation and floating slab								Ref: Pav 16
	Life-cycle phase	Environmental LCA impact categories						Embodied energy	
		ADP	GWP	ODP	AP	POCP	EP	ENR	ER
	Cradle-to-gate	8,40E-02	-4,56E+01	9,56E-07	5,47E-02	4,07E-03	7,84E-03	1,97E+02	6,66E+02
	End-of-life	2,40E-02	5,74E+01	5,54E-07	7,24E-01	8,90E-04	1,37E-02	5,57E+01	3,20E-01
	Total	1,08E-01	1,18E+01	1,51E-06	7,79E-01	4,96E-03	2,15E-02	2,53E+02	6,66E+02
<p>Comments: Considered Materials: wood (wood in floating floor and beams) and plasterboards, plasterboard panel, rock wool blanket and polyethylene foam.</p> <p>LCA Method(s): CML 2 baseline 2000 version 2.04 (to assess the environmental impact) and Cumulative Energy Demand version 1.04 (to assess the energy)</p> <p>LCI Libraries: Ecoinvent system process and ETH-ESU 96 system process</p>									

All.2 Exterior walls

The following pages present the results from the quantification of environmental impact categories of 28 alternative building elements for exterior walls. The meaning of the acronyms used in these pages, as well as the unit that express each of the environmental impact categories are shown in Table 6 of this book.

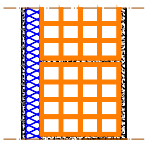
Building element	Single wall with the support element in masonry of bored brick (22cm), with reinforced plaster, on continuous insulation from outside								Ref: PExt 1
		Life-cycle phase	Environmental LCA impact categories					Embodied energy	
		ADP	GWP	ODP	AP	POCP	EP	ENR	ER
	Cradle-to-gate	2,48E-01	5,00E+01	3,02E-06	1,16E-01	1,23E-02	1,45E-02	5,63E+02	5,39E+01
	End of life	1,12E-01	1,65E+01	2,67E-06	7,60E-02	2,90E-03	1,58E-02	2,57E+02	1,57E+00
	Total	3,60E-01	6,65E+01	5,69E-06	1,92E-01	1,52E-02	3,03E-02	8,20E+02	5,54E+01
	Comments:	Considered Materials: Bored brick, armed plaster (exterior coating), expanded polystyrene moulded in plates (isolation), laying mortar and plaster (inner coating)							
		LCA Method(s): CML 2 baseline 2000 version 2.04 (to evaluate the environmental impact) and Cumulative Energy Demand version 1.04 (to evaluate the energy)							
		LCI Libraries: Ecoinvent system process							

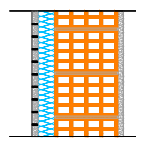
Building element	Single wall in masonry of bored brick, with thermal insulation, and exterior coating in reinforced plaster								Ref: PExt 2
		Life-cycle phase	Environmental LCA impact categories					Embodied energy	
		ADP	GWP	ODP	AP	POCP	EP	ENR	ER
	Cradle-to-gate	3,11E-01	6,11E+01	3,40E-06	1,42E-01	1,94E-02	1,74E-02	7,12E+02	6,24E+01
	End of life	1,27E-01	1,88E+01	3,05E-06	8,70E-02	3,40E-03	1,80E-02	2,92E+02	1,68E+00
	Total	4,38E-01	7,99E+01	6,45E-06	2,29E-01	2,28E-02	3,54E-02	1,00E+03	6,41E+01
	Comments:	Considered Materials: Bored brick (22cm), laying mortar, extruded expanded polystyrene (thermal insulation), reinforced plaster (exterior coating) and traditional plaster (inner coating)							
		LCA Method(s): CML 2 baseline 2000 version 2.04 (to evaluate the environmental impact) and Cumulative Energy Demand version 1.04 (to evaluate the energy)							
		LCI Libraries: Ecoinvent system process							

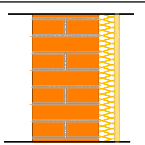
Building element	Single wall in masonry of massive brick (22cm), with thermal insulation, and inner coating in plasterboards, fixed in metallic structure								Ref: PExt 3
		Life-cycle phase	Environmental LCA impact categories					Embodied energy	
		ADP	GWP	ODP	AP	POCP	EP	ENR	ER
	Cradle-to-gate	5,94E-01	1,07E+02	6,83E-06	3,82E-01	2,21E-02	4,19E-02	1,31E+03	1,10E+02
	End of life	2,15E-01	3,10E+01	5,07E-06	1,47E-01	5,50E-03	3,04E-02	4,94E+02	2,94E+00
	Total	8,09E-01	1,38E+02	1,19E-05	5,29E-01	2,76E-02	7,23E-02	1,80E+03	1,13E+02
	Comments:	Considered Materials: Massive brick, rock wool (thermal insulation), plasterboards, laying mortar and galvanized steel (support structure)							
		LCA Method(s): CML 2 baseline 2000 version 2.04 (to evaluate the environmental impact) and Cumulative Energy Demand version 1.04 (to evaluate the energy)							
		LCI Libraries: Ecoinvent system process and IDEMAT 2001							

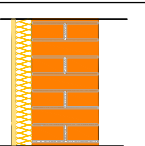
Building element	Single wall in masonry of massive brick, with thermal insulation and exterior coating in reinforced plaster								Ref: PExt 4
		Life-cycle phase	Environmental LCA impact categories					Embodied energy	
		ADP	GWP	ODP	AP	POCP	EP	ENR	ER
	Cradle-to-gate	5,30E-01	9,87E+01	6,29E-06	2,41E-01	2,70E-02	2,92E-02	1,18E+03	1,07E+02
	End of life	2,23E-01	3,23E+01	5,31E-06	1,51E-01	5,70E-03	3,14E-02	5,14E+02	3,14E+00
	Total	7,53E-01	1,31E+02	1,16E-05	3,92E-01	3,27E-02	6,06E-02	1,70E+03	1,10E+02
	Comments:	Considered Materials: Massive brick, laying mortar, extruded expanded polystyrene (thermal insulation) and reinforced plaster (exterior coating)							
		LCA Method(s): CML 2 baseline 2000 version 2.04 (to evaluate the environmental impact) and Cumulative Energy Demand version 1.04 (to evaluate the energy)							
		LCI Libraries: Ecoinvent system process							

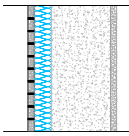
Building element	Single wall in reinforced concrete, with thermal insulation and exterior coating in armed plaster								Ref: PExt 5
	Life-cycle phase	Environmental LCA impact categories						Embodied energy	
		ADP	GWP	ODP	AP	POCP	EP	ENR	ER
	Cradle-to-gate	3,99E-01	9,64E+01	3,32E-06	2,05E-01	2,65E-02	3,33E-02	8,54E+02	2,95E+01
	End of life	3,29E-01	4,76E+01	7,68E-06	2,28E-01	8,50E-03	4,72E-02	7,53E+02	4,51E+00
	Total	7,28E-01	1,44E+02	1,10E-05	4,33E-01	3,50E-02	8,05E-02	1,61E+03	3,40E+01
Comments:		Considered Materials: Reinforced concrete (20cm), steel (steel bars), extruded expanded polystyrene (thermal insulation), reinforced plaster (exterior coating) and traditional plaster (inner coating)							
		LCA Method(s): CML 2 baseline 2000 version 2.04 (to evaluate the environmental impact) and Cumulative Energy Demand version 1.04 (to evaluate the energy)							
		LCI Libraries: Ecoinvent system process and IDEMAT 2001							

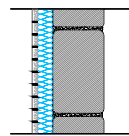
Building element	Single wall in stone masonry (20cm), with thermal insulation and thick exterior coating in reinforced plaster								Ref: PExt 6
	Life-cycle phase	Environmental LCA impact categories						Embodied energy	
		ADP	GWP	ODP	AP	POCP	EP	ENR	ER
	Cradle-to-gate	9,46E-01	1,59E+02	3,12E-04	7,67E-01	2,40E-02	1,49E-01	3,73E+03	4,03E+02
	End of life	2,44E-01	3,80E+01	6,00E-06	1,68E-01	6,50E-03	-1,31E-01	5,60E+02	2,55E+00
	Total	1,19E+00	1,97E+02	3,18E-04	9,35E-01	3,05E-02	1,83E-02	4,29E+03	4,05E+02
Comments:		Considered Materials: Stone, extruded expanded polystyrene (thermal insulation), reinforced plaster (exterior coating) and laying mortar							
		LCA Method(s): CML 2 baseline 2000 version 2.04 (to evaluate the environmental impact) and Cumulative Energy Demand version 1.04 (to evaluate the energy)							
		LCI Libraries: Ecoinvent system process							

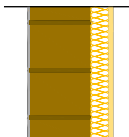
Building element	Single wall in masonry of adobe (20cm), with thermal insulation and inner coating in plasterboards, fixed in metallic structure								Ref: PExt 7
	Life-cycle phase	Environmental LCA impact categories						Embodied energy	
		ADP	GWP	ODP	AP	POCP	EP	ENR	ER
	Cradle-to-gate	1,78E-01	2,64E+01	1,24E-06	1,89E-01	8,07E-03	1,83E-02	3,94E+02	1,77E+01
	End of life	1,62E-01	2,53E+01	4,02E-06	1,13E-01	4,33E-03	2,32E-02	3,72E+02	2,06E+00
	Total	3,40E-01	5,17E+01	5,26E-06	3,02E-01	1,24E-02	4,15E-02	7,66E+02	1,98E+01
Comments:		Considered Materials: Masonry of adobe, rock wool (thermal insulation), plasterboards, plaster (exterior coating) and galvanized steel (support structure)							
		LCA Method(s): CML 2 baseline 2000 version 2.04 (to evaluate the environmental impact) and Cumulative Energy Demand version 1.04 (to evaluate the energy)							
		LCI Libraries: Ecoinvent system process and IDEMAT 2001							

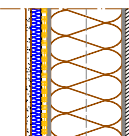
Building element	Wall with light metal frame in cold-rolled steel profiles								Ref: PExt 8
	Life-cycle phase	Environmental LCA impact categories						Embodied energy	
		ADP	GWP	ODP	AP	POCP	EP	ENR	ER
	Cradle-to-gate	4,79E-01	5,07E+01	2,20E-06	6,52E-01	3,03E-02	5,26E-02	1,11E+03	2,64E+02
	End of life	3,90E-02	6,10E+00	9,20E-07	3,00E-02	1,10E-03	6,40E-03	8,80E+01	4,25E-01
	Total	5,18E-01	5,68E+01	3,12E-06	6,82E-01	3,14E-02	5,90E-02	1,20E+03	2,64E+02
Comments:		Considered Materials: Plasterboards (inner coating), galvanized steel (profile), rock wool blankets, OSB panel, expanded polystyrene moulded in plates, reinforced plaster (exterior coating)							
		LCA Method(s): CML 2 baseline 2000 version 2.04 (to evaluate the environmental impact) and Cumulative Energy Demand version 1.04 (to evaluate the energy)							
		LCI Libraries: Ecoinvent system process and IDEMAT 2001							

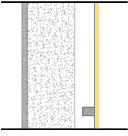
	Building element	Double wall with exterior cloth in masonry of reinforced concrete, box-of-air and inner coating in plasterboards, fixed in metallic structure							Ref: PExt 9
	Life-cycle phase	Environmental LCA impact categories						Embodied energy	
		ADP	GWP	ODP	AP	POCP	EP	ENR	ER
	Cradle-to-gate	3,75E-01	9,21E+01	3,32E-06	2,84E-01	1,80E-02	3,85E-02	7,98E+02	2,48E+01
	End of life	3,11E-01	4,49E+01	7,28E-06	2,15E-01	8,00E-03	4,46E-02	7,14E+02	4,31E+00
	Total	6,86E-01	1,37E+02	1,06E-05	4,99E-01	2,60E-02	8,31E-02	1,51E+03	2,92E+01
Comments:		Considered Materials: Concrete (20cm), steel (steel bars), galvanized steel (support structure), plaster (exterior coating) and plasterboards (inner coating)							
		LCA Method(s): CML 2 baseline 2000 version 2.04 (to evaluate the environmental impact) and Cumulative Energy Demand version 1.04 (to evaluate the energy)							
		LCI Libraries: Ecoinvent system process and IDEMAT 2001							

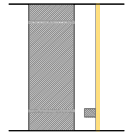
	Building element	Double wall with exterior cloth in stone masonry, box-of-air and inner coating in plasterboards, fixed in metallic structure							Ref: PExt 10
	Life-cycle phase	Environmental LCA impact categories						Embodied energy	
		ADP	GWP	ODP	AP	POCP	EP	ENR	ER
	Cradle-to-gate	9,16E-01	1,42E+02	1,64E-05	7,76E-01	2,71E-02	1,49E-01	3,65E+03	3,95E+02
	End of life	2,00E-03	0,00E+00	5,00E-07	3,00E-03	1,00E-04	1,00E-03	1,00E+01	0,00E+00
	Total	9,18E-01	1,42E+02	1,69E-05	7,79E-01	2,72E-02	1,50E-01	3,66E+03	3,95E+02
Comments:		Considered Materials: Stone (20cm), galvanised steel (support structure), laying mortar and plasterboards (inner coating)							
		LCA Method(s): CML 2 baseline 2000 version 2.04 (to evaluate the environmental impact) and Cumulative Energy Demand version 1.04 (to evaluate the energy)							
		LCI Libraries: Ecoinvent system process and IDEMAT 2001							

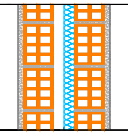
	Building element	Double wall, with exterior cloth in masonry of bored brick (11cm), box-of-air partially filled with thermal insulation, and interior cloth in masonry of bored brick (11cm)							Ref: PExt 11
	Life-cycle phase	Environmental LCA impact categories						Embodied energy	
		ADP	GWP	ODP	AP	POCP	EP	ENR	ER
	Cradle-to-gate	3,02E-01	6,99E+01	2,01E-04	1,45E-01	9,18E-03	1,81E-02	6,91E+02	6,74E+01
	End of life	1,39E-01	2,06E+01	3,00E-06	9,50E-02	3,62E-03	1,96E-02	3,19E+02	1,79E+00
	Total	4,41E-01	9,05E+01	2,04E-04	2,40E-01	1,28E-02	3,77E-02	1,01E+03	6,92E+01
Comments:		Considered Materials: Bored brick, laying mortar, extruded expanded polystyrene (thermal insulation) and plaster (coating)							
		LCA Method(s): CML 2 baseline 2000 version 2.04 (to evaluate the environmental impact) and Cumulative Energy Demand version 1.04 (to evaluate the energy)							
		LCI Libraries: Ecoinvent system process							

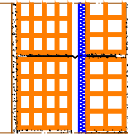
	Building element	Double wall in masonry of bored brick (15cm+11cm) with thermal insulation in XPS on the box-of-air							Ref: PExt 12
	Life-cycle phase	Environmental LCA impact categories						Embodied energy	
		ADP	GWP	ODP	AP	POCP	EP	ENR	ER
	Cradle-to-gate	3,70E-01	9,53E+01	1,02E-04	1,91E-01	1,13E-02	2,54E-02	8,68E+02	1,01E+02
	End of life	2,08E-01	3,17E+01	5,00E-06	1,42E-01	5,40E-03	2,95E-02	4,75E+02	2,83E+00
	Total	5,78E-01	1,27E+02	1,07E-04	3,33E-01	1,67E-02	5,49E-02	1,34E+03	1,04E+02
Comments:		Considered Materials: Bored brick, extruded expanded polystyrene (thermal insulation), laying mortar and plaster (coating)							
		LCA Method(s): CML 2 baseline 2000 version 2.04 (to evaluate the environmental impact) and Cumulative Energy Demand version 1.04 (to evaluate the energy)							
		LCI Libraries: Ecoinvent system process							

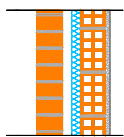
Building element	Double wall, with exterior cloth in masonry of mass brick (11cm), box-of-air partially filled with thermal insulation and interior cloth in masonry of bored brick (11cm)								Ref: PExt 13
		Life-cycle phase	Environmental LCA impact categories						Embodied energy
		ADP	GWP	ODP	AP	POCP	EP	ENR	ER
	Cradle-to-gate	5,66E-01	1,22E+02	2,04E-04	2,70E-01	1,80E-02	3,37E-02	1,28E+03	1,28E+02
	End of life	2,67E-01	4,00E+01	7,00E-06	1,83E-01	6,90E-03	3,77E-02	6,07E+02	4,17E+00
	Total	8,33E-01	1,62E+02	2,11E-04	4,53E-01	2,49E-02	7,14E-02	1,88E+03	1,32E+02
	Comments:	Considered Materials: Mass brick, bored brick, laying mortar, extruded expanded polystyrene (isolation) and plaster (inner coating)							
		LCA Method(s): CML 2 baseline 2000 version 2.04 (to evaluate the environmental impact) and Cumulative Energy Demand version 1.04 (to evaluate the energy)							
		LCI Libraries: Ecoinvent system process							

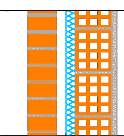
Building element	Double wall, with exterior cloth in masonry of mass brick (11cm), box-of-air partially filled with thermal insulation and interior cloth in masonry of bored brick (15cm)								Ref: PExt 14
		Life-cycle phase	Environmental LCA impact categories						Embodied energy
		ADP	GWP	ODP	AP	POCP	EP	ENR	ER
	Cradle-to-gate	5,94E-01	1,28E+02	2,05E-04	2,84E-01	1,89E-02	3,54E-02	1,33E+03	1,35E+02
	End of life	2,81E-01	4,10E+01	7,00E-06	1,91E-01	7,30E-03	3,96E-02	6,48E+02	3,39E+00
	Total	8,75E-01	1,69E+02	2,12E-04	4,75E-01	2,62E-02	7,50E-02	1,98E+03	1,38E+02
	Comments:	Considered Materials: Mass brick, bored brick, laying mortar, extruded expanded polystyrene (isolation) and plaster (inner coating)							
		LCA Method(s): CML 2 baseline 2000 version 2.04 (to evaluate the environmental impact) and Cumulative Energy Demand version 1.04 (to evaluate the energy)							
		LCI Libraries: Ecoinvent system process							

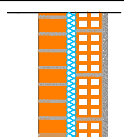
Building element	Double wall, with exterior cloth in masonry of mass brick (11cm), box-of-air totally filled with thermal insulation and interior cloth in masonry of bored brick (11cm)								Ref: PExt 15
		Life-cycle phase	Environmental LCA impact categories						Embodied energy
		ADP	GWP	ODP	AP	POCP	EP	ENR	ER
	Cradle-to-gate	5,66E-01	1,22E+02	2,04E-04	2,70E-01	1,80E-02	3,37E-02	1,28E+03	1,28E+02
	End of life	2,67E-01	4,00E+01	7,00E-06	1,83E-01	6,90E-03	3,77E-02	6,07E+02	4,17E+00
	Total	8,33E-01	1,62E+02	2,11E-04	4,53E-01	2,49E-02	7,14E-02	1,88E+03	1,32E+02
	Comments:	Considered Materials: Mass brick, bored brick, extruded expanded polystyrene (thermal insulation), laying mortar and plaster (inner coating)							
		LCA Method(s): CML 2 baseline 2000 version 2.04 (to evaluate the environmental impact) and Cumulative Energy Demand version 1.04 (to evaluate the energy)							
		LCI Libraries: Ecoinvent system process							

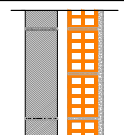
Building element	Double wall, with exterior cloth in stone masonry (12cm), box-of-air and interior cloth in masonry of bored brick (11cm)								Ref: PExt 16
		Life-cycle phase	Environmental LCA impact categories						Embodied energy
		ADP	GWP	ODP	AP	POCP	EP	ENR	ER
	Cradle-to-gate	6,38E-01	1,09E+02	1,14E-05	4,99E-01	1,72E-02	9,50E-02	2,40E+03	2,67E+02
	End of life	2,03E-01	3,20E+01	5,00E-06	1,41E-01	5,50E-03	2,90E-02	4,60E+02	3,53E+00
	Total	8,41E-01	1,41E+02	1,64E-05	6,40E-01	2,27E-02	1,24E-01	2,86E+03	2,71E+02
	Comments:	Considered Materials: Stone, bored brick, laying mortar and plaster (inner coating)							
		LCA Method(s): CML 2 baseline 2000 version 2.04 (to evaluate the environmental impact) and Cumulative Energy Demand version 1.04 (to evaluate the energy)							
		LCI Libraries: Ecoinvent system process							

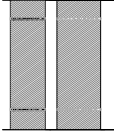
Building element	Double wall with exterior cloth in stone masonry (12cm), box-of-air and interior cloth in stone masonry (15cm)								Ref: PExt 17
	Life-cycle phase	Environmental LCA impact categories						Embodied energy	
		ADP	GWP	ODP	AP	POCP	EP	ENR	ER
	Cradle-to-gate	1,15E+00	1,80E+02	2,16E-05	9,81E-01	2,96E-02	1,95E-01	4,74E+03	5,29E+02
	End of life	3,00E-01	4,80E+01	7,60E-06	2,09E-01	8,10E-03	4,30E-02	7,00E+02	3,69E+00
	Total	1,45E+00	2,28E+02	2,92E-05	1,19E+00	3,77E-02	2,38E-01	5,44E+03	5,32E+02
Comments:	Considered Materials: Stone, laying mortar								
	LCA Method(s): CML 2 baseline 2000 version 2.04 (to evaluate the environmental impact) and Cumulative Energy Demand version 1.04 (to evaluate the energy)								
	LCI Libraries: Ecoinvent system process								

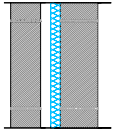
Building element	Double wall with exterior cloth in stone masonry (12cm), box-of-air partially filled with thermal insulation and interior cloth in stone masonry (15cm)								Ref: PExt 18
	Life-cycle phase	Environmental LCA impact categories						Embodied energy	
		ADP	GWP	ODP	AP	POCP	EP	ENR	ER
	Cradle-to-gate	1,20E+00	1,92E+02	2,19E-04	9,99E-01	3,06E-02	1,96E-01	4,85E+03	5,30E+02
	End of life	3,00E-01	4,70E+01	8,00E-06	2,11E-01	8,20E-03	4,40E-02	6,90E+02	3,69E+00
	Total	1,50E+00	2,39E+02	2,27E-04	1,21E+00	3,88E-02	2,40E-01	5,54E+03	5,34E+02
Comments:	Considered Materials: Stone, laying mortar and extruded expanded polystyrene (thermal insulation)								
	LCA Method(s): CML 2 baseline 2000 version 2.04 (to evaluate the environmental impact) and Cumulative Energy Demand version 1.04 (to evaluate the energy)								
	LCI Libraries: Ecoinvent system process								

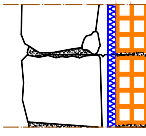
Building element	Double wall, with exterior cloth in carved stone masonry (30cm), interior cloth in masonry of bored brick (11cm) and with isolation in the box-of-air								Ref: PExt 19
	Life-cycle phase	Environmental LCA impact categories						Embodied energy	
		ADP	GWP	ODP	AP	POCP	EP	ENR	ER
	Cradle-to-gate	1,35E+00	2,30E+02	1,85E-04	1,08E+00	3,55E-02	2,08E-01	5,23E+03	5,77E+02
	End of life	4,00E-01	6,10E+01	1,00E-05	2,80E-01	1,05E-02	5,70E-02	9,00E+02	4,84E+00
	Total	1,75E+00	2,91E+02	1,95E-04	1,36E+00	4,60E-02	2,65E-01	6,13E+03	5,82E+02
Comments:	Considered Materials: Carved stone, bored brick, extruded expanded polystyrene (thermal insulation), laying mortar and plaster (coating)								
	LCA Method(s): CML 2 baseline 2000 version 2.04 (to evaluate the environmental impact) and Cumulative Energy Demand version 1.04 (to evaluate the energy)								
	LCI Libraries: Ecoinvent system process								

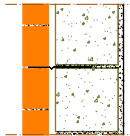
Building element	Double wall, with exterior cloth in masonry of mass brick (7cm) with facings and interior cloth in masonry of blocks of autoclaved aerated concrete (17,5cm), separated by box-of-air								Ref: PExt 20
	Life-cycle phase	Environmental LCA impact categories						Embodied energy	
		ADP	GWP	ODP	AP	POCP	EP	ENR	ER
	Cradle-to-gate	3,29E-01	8,50E+01	4,85E-06	1,04E-02	1,58E-01	2,02E-02	7,52E+02	6,23E+01
	End of life	1,32E-01	2,00E+01	3,19E-06	2,39E-01	-1,44E-01	1,87E-02	3,03E+02	2,31E+00
	Total	4,61E-01	1,05E+02	8,04E-06	2,49E-01	1,39E-02	3,89E-02	1,06E+03	6,46E+01
Comments:	Considered Materials: Blocks of autoclaved aerated concrete, mass brick, laying mortar and plaster (inner coating)								
	LCA Method(s): CML 2 baseline 2000 version 2.04 (to evaluate the environmental impact) and Cumulative Energy Demand version 1.04 (to evaluate the energy)								
	LCI Libraries: Ecoinvent system process								

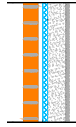
Building element	Double wall, with exterior cloth in masonry of mass brick (11cm), box-of-air partially filled with thermal insulation, and interior cloth in reinforced concrete (15cm)								Ref: PExt 21
		Life-cycle phase	Environmental LCA impact categories						Embodied energy
		ADP	GWP	ODP	AP	POCP	EP	ENR	ER
	Cradle-to-gate	7,57E-01	1,66E+02	2,05E-04	3,71E-01	3,03E-02	5,52E-02	1,62E+03	1,15E+02
	End of life	4,43E-01	6,50E+01	1,10E-05	3,08E-01	1,14E-02	6,38E-02	1,03E+03	6,30E+00
	Total	1,20E+00	2,31E+02	2,16E-04	6,79E-01	4,17E-02	1,19E-01	2,65E+03	1,21E+02
Comments:		Considered Materials: Mass brick, extruded expanded polystyrene (thermal insulation), concrete, steel (steel bars), laying mortar and plaster (inner coating)							
		LCA Method(s): CML 2 baseline 2000 version 2.04 (to evaluate the environmental impact) and Cumulative Energy Demand version 1.04 (to evaluate the energy)							
		LCI Libraries: Ecoinvent system process and IDEMAT 2001							

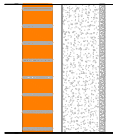
Building element	Double wall with exterior cloth in masonry of mass brick, box-of-air and interior cloth in reinforced concrete								Ref: PExt 22
		Life-cycle phase	Environmental LCA impact categories						Embodied energy
		ADP	GWP	ODP	AP	POCP	EP	ENR	ER
	Cradle-to-gate	7,08E-01	1,55E+02	7,92E-06	3,52E-01	2,92E-02	5,38E-02	1,51E+03	1,14E+02
	End of life	4,52E-01	6,40E+01	1,05E-05	3,08E-01	1,15E-02	6,32E-02	1,03E+03	6,20E+00
	Total	1,16E+00	2,19E+02	1,84E-05	6,60E-01	4,07E-02	1,17E-01	2,53E+03	1,20E+02
Comments:		Considered Materials: Mass brick (11cm), reinforced concrete (20cm), steel (steel bars), laying mortar and plaster (inner coating)							
		LCA Method(s): CML 2 baseline 2000 version 2.04 (to evaluate the environmental impact) and Cumulative Energy Demand version 1.04 (to evaluate the energy)							
		LCI Libraries: Ecoinvent system process and IDEMAT 2001							

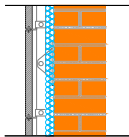
Building element	Ventilated wall with support element in masonry of mass brick and discontinuous exterior coating in stone plates, fixed in metallic structure								Ref: PExt 23
		Life-cycle phase	Environmental LCA impact categories						Embodied energy
		ADP	GWP	ODP	AP	POCP	EP	ENR	ER
	Cradle-to-gate	7,71E-01	1,35E+02	2,08E-04	4,82E-01	2,86E-02	7,14E-02	2,25E+03	2,25E+02
	End of life	2,39E-01	3,60E+01	5,00E-06	1,67E-01	6,30E-03	3,46E-02	5,56E+02	3,66E+00
	Total	1,01E+00	1,71E+02	2,13E-04	6,49E-01	3,49E-02	1,06E-01	2,81E+03	2,29E+02
Comments:		Considered Materials: Mass brick (22cm), stainless steel (fixation system), laying mortar, extruded expanded polystyrene (thermal insulation) and stone plate (exterior coating)							
		LCA Method(s): CML 2 baseline 2000 version 2.04 (to evaluate the environmental impact) and Cumulative Energy Demand version 1.04 (to evaluate the energy)							
		LCI Libraries: Ecoinvent system process and IDEMAT 2001							

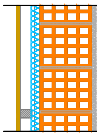
Building element	Ventilated wall with support element in masonry of bored brick and discontinuous exterior coating in agglomerate plates of wood and concrete, fixed in metallic structure								Ref: PExt 24
		Life-cycle phase	Environmental LCA impact categories						Embodied energy
		ADP	GWP	ODP	AP	POCP	EP	ENR	ER
	Cradle-to-gate	3,04E-01	6,10E+01	2,00E-04	1,66E-01	1,31E-02	1,84E-02	6,81E+02	7,77E+01
	End of life	1,17E-01	1,73E+01	3,00E-06	8,10E-02	3,10E-03	1,68E-02	2,71E+02	1,58E+00
	Total	4,21E-01	7,83E+01	2,03E-04	2,47E-01	1,62E-02	3,52E-02	9,52E+02	7,93E+01
Comments:		Considered Materials: Bored brick (22cm), galvanized steel (support structure), laying mortar, extruded expanded polystyrene (thermal insulation), agglomerate plates of wood/concrete (exterior coating) and plaster (inner coating)							
		LCA Method(s): CML 2 baseline 2000 version 2.04 (to evaluate the environmental impact) and Cumulative Energy Demand version 1.04 (to evaluate the energy)							
		LCI Libraries: Ecoinvent system process and IDEMAT 2001							

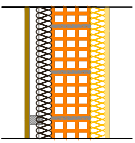
Building element	Triple wall with support element in masonry of bored brick, exterior coating in agglomerate plates of wood/concrete and inner coating in plasterboards fixed in metallic structure								Ref: PExt 25
	Life-cycle phase	Environmental LCA impact categories						Embodied energy	
		ADP	GWP	ODP	AP	POCP	EP	ENR	ER
	Cradle-to-gate	3,89E-01	4,38E+01	3,45E-06	2,50E-01	2,04E-02	2,76E-02	8,62E+02	2,61E+02
	End of life	8,70E-02	1,27E+01	2,04E-06	6,10E-02	2,30E-03	1,25E-02	1,98E+02	9,60E-01
	Total	4,76E-01	5,65E+01	5,49E-06	3,11E-01	2,27E-02	4,01E-02	1,06E+03	2,62E+02
<p>Comments: Considered Materials: Bored brick (15cm), plasterboards (inner coating), rock wool blanket (thermal insulation), laying mortar, black agglomerate of cork (thermal insulation), galvanized steel (support structure) and agglomerate plates of wood/concrete</p> <p>LCA Method(s): CML 2 baseline 2000 version 2.04 (to evaluate the environmental impact) and Cumulative Energy Demand version 1.04 (to evaluate the energy)</p> <p>LCI Libraries: Ecoinvent system process and IDEMAT 2001</p>									

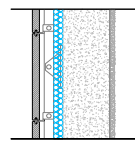
Building element	Ventilated wall with support element in reinforced concrete and discontinuous exterior coating in stone plates, fixed in metallic structure								Ref: PExt 26
	Life-cycle phase	Environmental LCA impact categories						Embodied energy	
		ADP	GWP	ODP	AP	POCP	EP	ENR	ER
	Cradle-to-gate	6,32E-01	1,32E+02	2,05E-04	4,39E-01	2,73E-02	7,49E-02	1,91E+03	1,48E+02
	End of life	3,43E-01	5,00E+01	8,00E-06	2,38E-01	8,80E-03	4,91E-02	7,92E+02	4,92E+00
	Total	9,75E-01	1,82E+02	2,13E-04	6,77E-01	3,61E-02	1,24E-01	2,70E+03	1,53E+02
<p>Comments: Considered Materials: Concrete (22cm), steel (steel bars), stainless steel (fixation system), laying mortar, extruded expanded polystyrene (thermal insulation), stone plate (exterior coating) and plaster (inner coating)</p> <p>LCA Method(s): CML 2 baseline 2000 version 2.04 (to evaluate the environmental impact) and Cumulative Energy Demand version 1.04 (to evaluate the energy)</p> <p>LCI Libraries: Ecoinvent system process and IDEMAT 2001</p>									

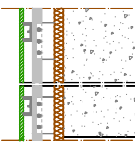
Building element	Ventilated wall with support element in masonry of lightweight concrete blocks (20cm) and discontinuous ceramic coating fixed in metallic structure								Ref: PExt 27
	Life-cycle phase	Environmental LCA impact categories						Embodied energy	
		ADP	GWP	ODP	AP	POCP	EP	ENR	ER
	Cradle-to-gate	5,47E-01	9,05E+01	7,94E-04	5,09E-01	2,53E-02	3,66E-02	1,25E+03	1,48E+02
	End of life	9,70E-02	1,45E+01	-7,84E-04	6,80E-02	2,60E-03	1,38E-02	2,26E+02	1,06E+00
	Total	6,44E-01	1,05E+02	1,03E-05	5,77E-01	2,79E-02	5,04E-02	1,48E+03	1,49E+02
<p>Comments: Considered Materials: Lightweight concrete blocks, black agglomerate of cork (isolation), laying mortar, plaster (inner coating), galvanized steel (fixation structure) and ceramic coating</p> <p>LCA Method(s): CML 2 baseline 2000 version 2.04 (to evaluate the environmental impact) and Cumulative Energy Demand version 1.04 (to evaluate the energy)</p> <p>LCI Libraries: Ecoinvent system process and IDEMAT 2001</p>									

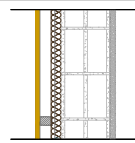
Building element	Ventilated wall with support element in masonry of bored concrete blocks and exterior coating in agglomerate plates of wood and concrete, fixed in metallic structure								Ref: PExt 28
	Life-cycle phase	Environmental LCA impact categories						Embodied energy	
		ADP	GWP	ODP	AP	POCP	EP	ENR	ER
	Cradle-to-gate	2,18E-01	3,60E+01	2,16E-06	1,52E-01	1,16E-02	1,92E-02	5,17E+02	2,49E+02
	End of life	1,18E-01	1,85E+01	2,90E-06	8,20E-02	3,20E-03	1,70E-02	2,71E+02	1,38E+00
	Total	3,36E-01	5,45E+01	5,06E-06	2,34E-01	1,48E-02	3,62E-02	7,88E+02	2,50E+02
<p>Comments: Considered Materials: Bored concrete block (20cm), galvanized steel (support structure), laying mortar, black agglomerate of cork (isolation), agglomerate plate of wood/concrete (exterior coating) and plaster (inner coating)</p> <p>LCA Method(s): CML 2 baseline 2000 version 2.04 (to evaluate the environmental impact) and Cumulative Energy Demand version 1.04 (to evaluate the energy)</p> <p>LCI Libraries: Ecoinvent system process and IDEMAT 2001</p>									

All.3 Interior walls

The following pages present the results from the quantification of the environmental impact categories of 28 alternative building elements for exterior walls. The meaning of the acronyms used in these pages, as well as the unit that express each of the environmental impact categories are shown in Table 6 of this book.

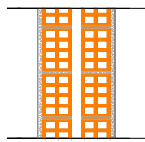
	Building element	Double wall with drilled brick masonry exterior cloth (11cm), air gap, and drilled brick masonry interior cloth (11cm)							Ref:
									Plnt 1
	Life-cycle phase	Environmental LCA impact categories						Embodied energy	
		ADP	GWP	ODP	AP	POCP	EP	ENR	ER
	Cradle-to-gate	2,53E-01	5,84E+01	3,55E-06	1,27E-01	8,17E-03	1,67E-02	5,79E+02	6,61E+01
	End of life	1,39E-01	2,05E+01	3,31E-06	9,50E-02	3,63E-03	1,95E-02	3,19E+02	1,89E+00
	Total	3,92E-01	7,89E+01	6,86E-06	2,22E-01	1,18E-02	3,62E-02	8,98E+02	6,80E+01
Comments:		Considered Materials: drilled brick, laying mortar and plastering (coating)							
		LCA Method(s): CML 2 baseline 2000 version 2.04 (to assess the environmental impact) and Cumulative Energy Demand version 1.04 (to assess the energy)							
		LCI Libraries: Ecoinvent system process							

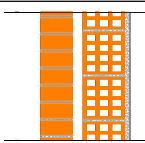
	Building element	Double wall with solid brick masonry exterior cloth (11cm), air gap, and drilled brick masonry interior cloth (15cm)							Ref:
									Plnt 2
	Life-cycle phase	Environmental LCA impact categories						Embodied energy	
		ADP	GWP	ODP	AP	POCP	EP	ENR	ER
	Cradle-to-gate	5,45E-01	1,16E+02	7,51E-06	2,65E-01	1,79E-02	3,40E-02	1,22E+03	1,33E+02
	End of life	2,81E-01	4,20E+01	6,69E-06	1,92E-01	7,20E-03	3,95E-02	6,30E+02	4,39E+00
	Total	8,26E-01	1,58E+02	1,42E-05	4,57E-01	2,51E-02	7,35E-02	1,85E+03	1,37E+02
Comments:		Considered Materials: drilled brick, solid brick, laying mortar and plastering (interior coating)							
		LCA Method(s): CML 2 baseline 2000 version 2.04 (to assess the environmental impact) and Cumulative Energy Demand version 1.04 (to assess the energy)							
		LCI Libraries: Ecoinvent system process							

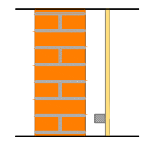
	Building element	Double wall with solid brick masonry exterior cloth, air gap, and interior lining in plasterboards, set in a metal frame							Ref:
									Plnt 3
	Life-cycle phase	Environmental LCA impact categories						Embodied energy	
		ADP	GWP	ODP	AP	POCP	EP	ENR	ER
	Cradle-to-gate	4,90E-01	9,08E+01	6,19E-06	2,50E-01	1,95E-02	2,98E-02	1,08E+03	9,92E+01
	End of life	2,12E-01	3,02E+01	5,01E-06	1,45E-01	5,40E-03	3,00E-02	4,85E+02	2,94E+00
	Total	7,02E-01	1,21E+02	1,12E-05	3,95E-01	2,49E-02	5,98E-02	1,57E+03	1,02E+02
Comments:		Considered Materials: Solid brick (22cm), galvanized steel (support structure), laying mortar and plasterboards (interior coating)							
		LCA Method(s): CML 2 baseline 2000 version 2.04 (to assess the environmental impact) and Cumulative Energy Demand version 1.04 (to assess the energy)							
		LCI Libraries: Ecoinvent system process and IDEMAT 2001							

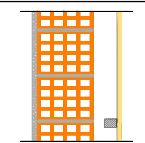
	Building element	Double wall with drilled brick masonry exterior cloth, air gap, and interior lining in plasterboards, set in a metal frame							Ref:
									Plnt 4
	Life-cycle phase	Environmental LCA impact categories						Embodied energy	
		ADP	GWP	ODP	AP	POCP	EP	ENR	ER
	Cradle-to-gate	2,71E-01	5,31E+01	3,29E-06	1,51E-01	1,19E-02	1,80E-02	6,09E+02	5,50E+01
	End of life	9,80E-02	1,53E+01	2,43E-06	6,90E-02	2,70E-03	1,41E-02	2,25E+02	1,16E+00
	Total	3,69E-01	6,84E+01	5,72E-06	2,20E-01	1,46E-02	3,21E-02	8,34E+02	5,62E+01
Comments:		Considered Materials: drilled brick (22cm), galvanized steel (support structure), laying mortar, plastering (exterior coating) and plasterboards (interior coating)							
		LCA Method(s): CML 2 baseline 2000 version 2.04 (to assess the environmental impact) and Cumulative Energy Demand version 1.04 (to assess the energy)							
		LCI Libraries: Ecoinvent system process and IDEMAT 2001							

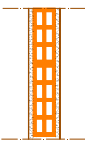
Building element	Single wall in brick masonry of 7cm									Ref:
										Plnt 5
		Life-cycle phase	Environmental LCA impact categories						Embodied energy	
ADP	GWP		ODP	AP	POCP	EP	ENR	ER		
		Cradle-to-gate	9,82E-02	2,51E+01	1,41E-06	5,13E-02	3,08E-03	6,95E-03	2,30E+02	2,81E+01
		End of life	5,88E-02	8,70E+00	1,41E-06	4,00E-02	1,53E-03	8,25E-03	1,35E+02	7,77E-01
		Total	1,57E-01	3,38E+01	2,82E-06	9,13E-02	4,61E-03	1,52E-02	3,65E+02	2,89E+01
Comments:		Considered Materials: drilled brick (7cm), laying mortar and plastering (exterior coating)								
		LCA Method(s): CML 2 baseline 2000 version 2.04 (to assess the environmental impact) and Cumulative Energy Demand version 1.04 (to assess the energy)								
		LCI Libraries: Ecoinvent system process								

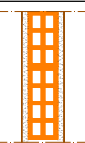
Building element	Single wall in brick masonry of 9cm									Ref:
										Plnt 6
		Life-cycle phase	Environmental LCA impact categories						Embodied energy	
ADP	GWP		ODP	AP	POCP	EP	ENR	ER		
		Cradle-to-gate	1,18E-01	2,90E+01	1,68E-06	6,07E-02	3,74E-03	8,13E-03	2,74E+02	3,27E+01
		End of life	6,80E-02	1,02E+01	1,63E-06	4,63E-02	1,78E-03	9,57E-03	1,56E+02	9,01E-01
		Total	1,86E-01	3,92E+01	3,31E-06	1,07E-01	5,52E-03	1,77E-02	4,30E+02	3,36E+01
Comments:		Considered Materials: drilled brick (9cm), laying mortar and plastering (exterior coating)								
		LCA Method(s): CML 2 baseline 2000 version 2.04 (to assess the environmental impact) and Cumulative Energy Demand version 1.04 (to assess the energy)								
		LCI Libraries: Ecoinvent system process								

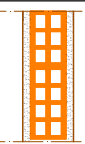
Building element	Single wall in brick masonry of 11cm									Ref:
										Plnt 7
		Life-cycle phase	Environmental LCA impact categories						Embodied energy	
ADP	GWP		ODP	AP	POCP	EP	ENR	ER		
		Cradle-to-gate	1,38E-01	3,29E+01	1,95E-06	7,01E-02	4,41E-03	9,30E-03	3,18E+02	3,72E+01
		End of life	7,80E-02	1,16E+01	1,86E-06	5,29E-02	2,02E-03	1,10E-02	1,78E+02	1,00E+00
		Total	2,16E-01	4,45E+01	3,81E-06	1,23E-01	6,43E-03	2,03E-02	4,96E+02	3,82E+01
Comments:		Considered Materials: drilled brick (11cm), laying mortar and plastering (exterior coating)								
		LCA Method(s): CML 2 baseline 2000 version 2.04 (to assess the environmental impact) and Cumulative Energy Demand version 1.04 (to assess the energy)								
		LCI Libraries: Ecoinvent system process								

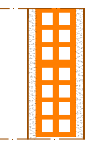
Building element	Single wall in brick masonry of 15cm									Ref:
										Plnt 8
		Life-cycle phase	Environmental LCA impact categories						Embodied energy	
ADP	GWP		ODP	AP	POCP	EP	ENR	ER		
		Cradle-to-gate	1,62E-01	3,79E+01	2,28E-06	8,18E-02	5,22E-03	1,08E-02	3,72E+02	4,29E+01
		End of life	9,00E-02	1,33E+01	2,15E-06	6,12E-02	2,33E-03	1,26E-02	2,07E+02	1,27E+00
		Total	2,52E-01	5,12E+01	4,43E-06	1,43E-01	7,55E-03	2,34E-02	5,79E+02	4,41E+01
Comments:		Considered Materials: drilled brick (15cm), laying mortar and plastering (exterior coating)								
		LCA Method(s): CML 2 baseline 2000 version 2.04 (to assess the environmental impact) and Cumulative Energy Demand version 1.04 (to assess the energy)								
		LCI Libraries: Ecoinvent system process								

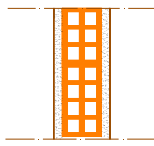
Building element	Single wall in brick masonry of 22cm								Ref: Plnt 9
	Life-cycle phase	Environmental LCA impact categories						Embodied energy	
		ADP	GWP	ODP	AP	POCP	EP	ENR	ER
	Cradle-to-gate	2,17E-01	4,88E+01	3,02E-06	1,08E-01	7,02E-03	1,40E-02	4,93E+02	5,54E+01
	End of life	1,16E-01	1,71E+01	2,77E-06	7,90E-02	2,98E-03	1,64E-02	2,67E+02	1,58E+00
Total	3,33E-01	6,59E+01	4,79E-06	1,87E-01	1,00E-03	3,04E-02	7,59E+02	5,70E+01	
<p>Comments: Considered Materials: drilled brick (22cm), laying mortar and plastering (exterior coating)</p> <p>LCA Method(s): CML 2 baseline 2000 version 2.04 (to assess the environmental impact) and Cumulative Energy Demand version 1.04 (to assess the energy)</p> <p>LCI Libraries: Ecoinvent system process</p>									

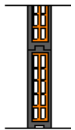
Building element	Prefabricated panels of brick masonry coated by plaster								Ref: Plnt 10
	Life-cycle phase	Environmental LCA impact categories						Embodied energy	
		ADP	GWP	ODP	AP	POCP	EP	ENR	ER
	Cradle-to-gate	7,79E-02	1,52E01	1,06E-06	3,82E-02	2,82E-03	4,70E-03	1,57E02	5,00E00
	End of life	4,45E-03	6,12E-01	1,32E-07	3,64E-03	1,19E-04	7,29E-04	9,73E00	4,56E-03
Total	8,23E-02	1,58E01	1,19E-06	4,18E-02	2,94E-03	5,43E-03	1,67E02	5,00E00	
<p>Comments: Considered Materials: drilled brick coated in plaster.</p> <p>LCA Method(s): CML 2 baseline 2000 version 2.04 (to assess the environmental impact) and Cumulative Energy Demand version 1.04 (to assess the energy)</p> <p>LCI Libraries: Ecoinvent system process</p>									

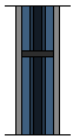
Building element	Masonry blocks of lightweight concrete of 8								Ref: Plnt 11
	Life-cycle phase	Environmental LCA impact categories						Embodied energy	
		ADP	GWP	ODP	AP	POCP	EP	ENR	ER
	Cradle-to-gate	3,60E-01	7,87E01	6,24E-06	4,45E-01	1,83E-02	2,89E-02	7,69E02	6,18E00
	End of life	1,40E-02	1,93E00	4,15E-07	1,15E-02	3,77E-04	2,30E-03	3,07E01	1,44E-02
Total	3,74E-01	8,06E01	6,65E-06	4,57E-01	1,87E-02	3,12E-02	8,00E02	6,18E00	
<p>Comments: Considered Materials: Lightweight concrete blocks of 8, laying mortar and 1.5cm of plaster on both sides.</p> <p>LCA Method(s): CML 2 baseline 2000 version 2.04 (to assess the environmental impact) and Cumulative Energy Demand version 1.04 (to assess the energy)</p> <p>LCI Libraries: Ecoinvent system process</p>									

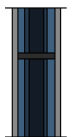
Building element	Masonry blocks of lightweight concrete of 10								Ref: Plnt 12
	Life-cycle phase	Environmental LCA impact categories						Embodied energy	
		ADP	GWP	ODP	AP	POCP	EP	ENR	ER
	Cradle-to-gate	4,42E-01	9,56E01	7,69E-06	5,52E-01	2,27E-02	3,54E-02	9,48E02	7,14E00
	End of life	1,66E-02	2,29E00	4,92E-07	1,36E-02	4,47E-04	2,73E-03	3,64E01	1,71E-02
Total	4,59E-01	9,79E01	8,18E-06	5,66E-01	2,32E-02	3,81E-02	9,84E02	7,14E00	
<p>Comments: Considered Materials: Lightweight concrete blocks of 10, laying mortar and 1.5cm of plaster on both sides.</p> <p>LCA Method(s): CML 2 baseline 2000 version 2.04 (to assess the environmental impact) and Cumulative Energy Demand version 1.04 (to assess the energy)</p> <p>LCI Libraries: Ecoinvent system process</p>									

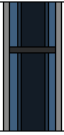
Building element	Masonry blocks of lightweight concrete of 12									Ref: Plnt 13
	Life-cycle phase	Environmental LCA impact categories							Embodied energy	
		ADP	GWP	ODP	AP	POCP	EP	ENR	ER	
	Cradle-to-gate	5.25E-1	1.12E2	9.13E-6	6.59E-1	2.71E-2	4.19E-2	1.13E3	8.08E0	
	End of life	0.0192	2.65E0	5.69E-7	1.57E-2	5.16E-4	3.15E-3	4.21E1	1.98E-2	
	Total	5.45E-1	1.15E2	9.70E-6	6.75E-1	2.76E-2	4.51E-2	1.17E3	8.11E0	
Comments:		Considered Materials: Lightweight concrete blocks of 12, laying mortar and 1.5cm of plaster on both sides.								
		LCA Method(s): CML 2 baseline 2000 version 2.04 (to assess the environmental impact) and Cumulative Energy Demand version 1.04 (to assess the energy)								
		LCI Libraries: Ecoinvent system process								

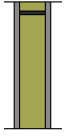
Building element	Masonry blocks of autoclaved aerated concrete of 7.5									Ref: Plnt 14
	Life-cycle phase	Environmental LCA impact categories							Embodied energy	
		ADP	GWP	ODP	AP	POCP	EP	ENR	ER	
	Cradle-to-gate	1.96E-1	6.18E1	3.08E-6	1.03E-1	5.94E-3	1.35E-2	3.84E2	5.44E0	
	End of life	1.17E-2	1.61E0	3.46E-7	9.57E-3	3.14E-4	1.92E-3	2.56E1	1.20E-2	
	Total	2.08E-1	6.34E1	3.42E-6	1.12E-1	6.26E-3	1.54E-2	4.09E2	5.44E0	
Comments:		Considered Materials: blocks of autoclaved aerated concrete of 8, laying mortar and 1.5cm of plaster on both sides.								
		LCA Method(s): CML 2 baseline 2000 version 2.04 (to assess the environmental impact) and Cumulative Energy Demand version 1.04 (to assess the energy)								
		LCI Libraries: Ecoinvent system process								

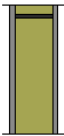
Building element	Masonry blocks of autoclaved aerated concrete of 10									Ref: Plnt 15
	Life-cycle phase	Environmental LCA impact categories							Embodied energy	
		ADP	GWP	ODP	AP	POCP	EP	ENR	ER	
	Cradle-to-gate	2.53E-1	7.87E1	3.95E-6	1.31E-1	7.69E-3	1.7E-2	4.93E2	6.48E0	
	End of life	1.44E-2	1.98E0	4.26E-7	1.18E-2	3.86E-4	2.36E-3	3.15E1	1.48E-2	
	Total	2.67E-1	8.07E1	4.38E-6	1.42E-1	8.07E-3	1.94E-2	5.25E2	6.48E0	
Comments:		Considered Materials: blocks of autoclaved aerated concrete of 10, laying mortar and 1.5cm of plaster on both sides.								
		LCA Method(s): CML 2 baseline 2000 version 2.04 (to assess the environmental impact) and Cumulative Energy Demand version 1.04 (to assess the energy)								
		LCI Libraries: Ecoinvent system process								

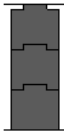
Building element	Masonry blocks of interlocked lightweight concrete									Ref: Plnt 16
	Life-cycle phase	Environmental LCA impact categories							Embodied energy	
		ADP	GWP	ODP	AP	POCP	EP	ENR	ER	
	Cradle-to-gate	1.72E-1	3.45E1	3.00E-6	2.23E-1	9.20E-3	1.34E-2	3.71E2	1.79E0	
	End of life	5.11E-3	7.04E-1	1.51E-7	4.18E-3	1.37E-4	8.38E-4	1.12E1	5.23E-3	
	Total	1.77E-1	3.52E1	3.16E-6	2.27E-1	9.33E-3	1.43E-2	3.82E2	1.79E0	
Comments:		Considered Materials: blocks of interlocked lightweight concrete								
		LCA Method(s): CML 2 baseline 2000 version 2.04 (to assess the environmental impact) and Cumulative Energy Demand version 1.04 (to assess the energy)								
		LCI Libraries: Ecoinvent system process								

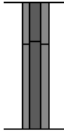
Building element	Masonry block of plaster									Ref: Plnt 17
	Life-cycle phase	Environmental LCA impact categories						Embodied energy		
		ADP	GWP	ODP	AP	POCP	EP	ENR	ER	
	Cradle-to-gate	8.36E-2	3.31E1	1.41E-6	5.28E-2	2.42E-3	8.11E-3	1.65E2	6.54E0	
	End of life	9.70E-3	1.34E0	2.88E-7	7.95E-3	2.61E-4	1.59E-3	2.12E1	9.96E-3	
	Total	9.33E-2	3.45E1	1.70E-6	6.08E-2	2.68E-3	9.70E-3	1.86E2	6.54E0	
Comments:		Considered Materials: plaster blocks with plaster glue.								
		LCA Method(s): CML 2 baseline 2000 version 2.04 (to assess the environmental impact) and Cumulative Energy Demand version 1.04 (to assess the energy)								
		LCI Libraries: Ecoinvent system process								

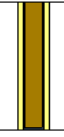
Building element	Lightweight wall in prefabricated panels of plasterboard with insulation in mineral wool filling fully the air gap									Ref: Plnt 18
	Life-cycle phase	Environmental LCA impact categories						Embodied energy		
		ADP	GWP	ODP	AP	POCP	EP	ENR	ER	
	Cradle-to-gate	9.10E-2	1.29E1	2.82E-6	1.99E-1	1.14E-2	6.20E-3	1.70E2	1.45E0	
	End of life	1.58E-3	2.18E-1	4.68E-8	1.29E-3	4.24E-5	2.59E-4	3.46E0	1.62E-3	
	Total	9.26E-2	1.31E1	2.86E-6	2.0E-1	1.14E-2	6.46E-3	1.73E2	1.45E0	
Comments:		Considered Materials: plasterboard prefabricated panels, rock wool and structure of metallic profiles of galvanized steel.								
		LCA Method(s): CML 2 baseline 2000 version 2.04 (to assess the environmental impact) and Cumulative Energy Demand version 1.04 (to assess the energy)								
		LCI Libraries: Ecoinvent system process								

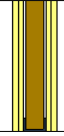
Building element	Lightweight wall with vestments composed by two layers of prefabricated panels of plasterboard, with insulation in mineral wool filling totally the air gap									Ref: Plnt 19
	Life-cycle phase	Environmental LCA impact categories						Embodied energy		
		ADP	GWP	ODP	AP	POCP	EP	ENR	ER	
	Cradle-to-gate	1.49E-1	2.11E1	3.72E-6	2.25E-1	1.25E-2	1.03E-2	2.87E2	2.90E0	
	End of life	3.03E-3	4.18E-1	8.98E-8	2.48E-3	8.15E-5	4.97E-4	6.64E0	3.11E-3	
	Total	1.52E-1	2.15E1	3.81E-6	2.28E-1	1.25E-2	1.08E-2	2.93E2	2.91E0	
Comments:		Considered Materials: plasterboard prefabricated panels, rock wool and structure of metallic profiles of galvanized steel.								
		LCA Method(s): CML 2 baseline 2000 version 2.04 (to assess the environmental impact) and Cumulative Energy Demand version 1.04 (to assess the energy)								
		LCI Libraries: Ecoinvent system process								

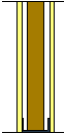
Building element	Lightweight wall with prefabricated panels of plasterboard with insulation in mineral wool partially filling the air gap									Ref: Plnt 20
	Life-cycle phase	Environmental LCA impact categories						Embodied energy		
		ADP	GWP	ODP	AP	POCP	EP	ENR	ER	
	Cradle-to-gate	9.46E-2	1.32E1	2.2E-6	5.00E-2	5.67E-3	6.56E-3	1.78E2	1.67E0	
	End of life	1.81E-3	2.50E-1	5.37E-8	1.49E-3	4.87E-5	2.97E-4	3.97E0	5.59E-3	
	Total	9.64E-2	1.35E1	2.26E-6	5.15E-2	5.72E-3	6.86E-3	1.82E2	1.68E0	
Comments:		Considered Materials: plasterboard prefabricated panels, rock wool and structure of metallic profiles of galvanized steel.								
		LCA Method(s): CML 2 baseline 2000 version 2.04 (to assess the environmental impact) and Cumulative Energy Demand version 1.04 (to assess the energy)								
		LCI Libraries: Ecoinvent system process								

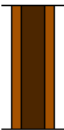
Building element	Freestanding system wall composed by MDF boards									Ref: Pint 21
	Life-cycle phase	Environmental LCA impact categories						Embodied energy		
		ADP	GWP	ODP	AP	POCP	EP	ENR	ER	
	Cradle-to-gate	1.38E-1	-9.65E1	1.34E-6	6.17E-2	3.69E-3	6.86E-3	2.71E2	4.43E2	
	End of life	5.17E-6	7.12E-4	1.53E-10	4.24E-6	1.39E-7	8.48E-7	1.13E-2	5.30E-6	
	Total	1.38E-1	-9.65E1	1.34E-6	6.17E-2	3.69E-3	6.86E-3	2.71E2	4.43E2	
<p>Comments: Considered Materials: structure of solid wood and MDF panels.</p> <p>LCA Method(s): CML 2 baseline 2000 version 2.04 (to assess the environmental impact) and Cumulative Energy Demand version 1.04 (to assess the energy)</p> <p>LCI Libraries: Ecoinvent system process</p>										

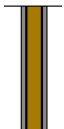
Building element	Wall of wood-cement									Ref: Pint 22
	Life-cycle phase	Environmental LCA impact categories						Embodied energy		
		ADP	GWP	ODP	AP	POCP	EP	ENR	ER	
	Cradle-to-gate	1.36E-1	2.04E1	3.46E-6	2.31E-1	1.52E-2	1.01E-2	2.54E2	3.77E1	
	End of life	1.99E-4	2.74E-2	5.89E-9	1.63E-4	5.34E-6	3.26E-5	4.35E-1	2.04E-4	
	Total	1.36E-1	2.04E1	3.46E-6	2.31E-1	1.52E-2	1.01E-2	2.54E2	3.77E1	
<p>Comments: Considered Materials: prefabricated panels of wood-cement, including rock wool and structure of metallic profiles of galvanized steel.</p> <p>LCA Method(s): CML 2 baseline 2000 version 2.04 (to assess the environmental impact) and Cumulative Energy Demand version 1.04 (to assess the energy)</p> <p>LCI Libraries: Ecoinvent system process</p>										

All.4 Roofs

The following pages present the results from the quantification of the environmental impact categories of 23 alternative building elements for roofs. The meaning of the acronyms used in these pages, as well as the unit that express each of the environmental impact categories are shown in Table 6 of this book.

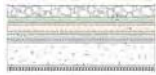
Building element	Traditional flat roof with exterior coating in cobble and support in reinforced concrete								Ref: Cob 1
Life-cycle phase	Environmental LCA impact categories							Embodied energy	
	ADP	GWP	ODP	AP	POCP	EP	ENR	ER	
 Cradle-to-gate	8,41E-01	1,62E+02	9,73E-06	7,29E-01	4,39E-02	7,74E-02	1,61E+03	2,29E+01	
End of life	-2,47E-01	-1,64E+01	4,19E-07	-7,92E-02	-1,87E-02	-1,04E-02	-3,47E+02	-1,15E+00	
Total	5,94E-01	1,46E+02	1,01E-05	6,50E-01	2,52E-02	6,70E-02	1,26E+03	2,17E+01	
<p>Comments: Considered Materials: lightweight concrete, expanded polystyrene, mortar, cobble and geotextile.</p> <p>LCA Method(s): CML 2 baseline 2000 version 2.04 (to evaluate the environmental impact) and Cumulative Energy Demand version 1.04 (to evaluate the energy)</p> <p>LCI Libraries: Ecoinvent system process</p>									

Building element	Traditional flat roof with exterior coating in ceramic mosaic and support in lightweight slab of ceramic blocks								Ref: Cob 2
Life-cycle phase	Environmental LCA impact categories							Embodied energy	
	ADP	GWP	ODP	AP	POCP	EP	ENR	ER	
 Cradle-to-gate	1,01E+00	1,98E+02	1,21E-05	8,17E-01	4,77E-02	8,75E-02	1,93E+03	4,35E+01	
End of life	-2,52E-01	-1,70E+01	2,91E-07	-8,27E-02	-1,88E-02	-1,11E-02	-3,56E+02	-1,17E+00	
Total	7,58E-01	1,81E+02	1,24E-05	7,34E-01	2,89E-02	7,64E-02	1,57E+03	4,23E+01	
<p>Comments: Considered Materials: lightweight concrete, expanded polystyrene, coatings, mortar, screed and geotextile.</p> <p>LCA Method(s): CML 2 baseline 2000 version 2.04 (to evaluate the environmental impact) and Cumulative Energy Demand version 1.04 (to evaluate the energy)</p> <p>LCI Libraries: Ecoinvent system process</p>									

Building element	Traditional flat roof with exterior coating in hydraulic mosaic and support in lightweight slab of ceramic blocks								Ref: Cob 3
Life-cycle phase	Environmental LCA impact categories							Embodied energy	
	ADP	GWP	ODP	AP	POCP	EP	ENR	ER	
 Cradle-to-gate	8,68E+01	4,02E+04	1,30E-03	6,56E+01	2,38E+00	1,04E+01	1,65E+05	2,29E+03	
End of life	-6,56E-02	-3,08E+00	6,76E-07	-1,20E-02	-5,84E-03	-5,60E-04	-7,77E+01	-3,37E-01	
Total	8,67E+01	4,02E+04	1,30E-03	6,56E+01	2,37E+00	1,04E+01	1,65E+05	2,29E+03	
<p>Comments: Considered Materials: concrete, plaster mortar, geotextile and ceramic pot.</p> <p>LCA Method(s): CML 2 baseline 2000 version 2.04 (to evaluate the environmental impact) and Cumulative Energy Demand version 1.04 (to evaluate the energy)</p> <p>LCI Libraries: Ecoinvent system process</p>									

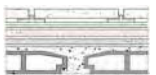
Building element	Traditional flat roof with exterior coating in hydraulic mosaic and support in lightweight slab of blocks of normal concrete								Ref: Cob 4
Life-cycle phase	Environmental LCA impact categories							Embodied energy	
	ADP	GWP	ODP	AP	POCP	EP	ENR	ER	
 Cradle-to-gate	8,68E+01	4,02E+04	1,29E-03	6,56E+01	2,38E+00	1,04E+01	1,65E+05	2,28E+03	
End of life	-6,59E-02	-3,11E+00	6,68E-07	-1,22E-02	-5,85E-03	-6,05E-04	-7,83E+01	-3,37E-01	
Total	8,67E+01	4,02E+04	1,29E-03	6,56E+01	2,37E+00	1,04E+01	1,65E+05	2,28E+03	
<p>Comments: Considered Materials: concrete, plaster mortar, geotextile, block of normal concrete.</p> <p>LCA Method(s): CML 2 baseline 2000 version 2.04 (to evaluate the environmental impact) and Cumulative Energy Demand version 1.04 (to evaluate the energy)</p> <p>LCI Libraries: Ecoinvent system process</p>									

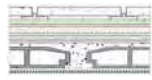
Building element	Flat roof with thermal insulation under the waterproofing, with support in lightweight slab of blocks of lightweight concrete								Ref: Cob 5
Life-cycle phase	Environmental LCA impact categories							Embodied energy	
	ADP	GWP	ODP	AP	POCP	EP	ENR	ER	
 Cradle-to-gate	8,69E+01	4,02E+04	1,30E-03	6,57E+01	2,39E+00	1,04E+01	1,65E+05	2,28E+03	
End of life	-6,64E-02	-3,19E+00	6,52E-07	-1,27E-02	-5,87E-03	-6,95E-04	-7,95E+01	-3,39E-01	
Total	8,68E+01	4,02E+04	1,30E-03	6,57E+01	2,38E+00	1,04E+01	1,65E+05	2,28E+03	
Comments: Considered Materials: concrete, plaster mortar, geotextile, block of lightweight concrete.									
LCA Method(s): CML 2 baseline 2000 version 2.04 (to evaluate the environmental impact) and Cumulative Energy Demand version 1.04 (to evaluate the energy)									
LCI Libraries: Ecoinvent system process									

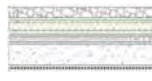
Building element	Flat roof with thermal insulation under the waterproofing with exterior coating in cobble								Ref: Cob 6
Life-cycle phase	Environmental LCA impact categories							Embodied energy	
	ADP	GWP	ODP	AP	POCP	EP	ENR	ER	
 Cradle-to-gate	8,65E-01	1,61E+02	1,07E-05	7,23E-01	4,41E-02	7,66E-02	1,67E+03	2,49E+01	
End of life	-2,47E-01	-1,64E+01	4,22E-07	-7,91E-02	-1,87E-02	-1,04E-02	-3,46E+02	-1,15E+00	
Total	6,18E-01	1,45E+02	1,11E-05	6,44E-01	2,54E-02	6,62E-02	1,32E+03	2,37E+01	
Comments: Considered Materials: concrete, plaster mortar, geotextile and cobble.									
LCA Method(s): CML 2 baseline 2000 version 2.04 (to evaluate the environmental impact) and Cumulative Energy Demand version 1.04 (to evaluate the energy)									
LCI Libraries: Ecoinvent system process									

Building element	Flat roof with thermal insulation under the waterproofing with exterior coating in concrete slabs on spacers								Ref: Cob 7
Life-cycle phase	Environmental LCA impact categories							Embodied energy	
	ADP	GWP	ODP	AP	POCP	EP	ENR	ER	
 Cradle-to-gate	8,70E+01	4,02E+04	1,30E-03	6,57E+01	2,40E+00	1,04E+01	1,65E+05	2,29E+03	
End of life	-2,50E-01	-1,69E+01	3,29E-07	-8,17E-02	-1,88E-02	-1,09E-02	-3,53E+02	-1,16E+00	
Total	8,68E+01	4,02E+04	1,30E-03	6,56E+01	2,38E+00	1,04E+01	1,65E+05	2,29E+03	
Comments: Considered Materials: concrete, plaster mortar, geotextile.									
LCA Method(s): CML 2 baseline 2000 version 2.04 (to evaluate the environmental impact) and Cumulative Energy Demand version 1.04 (to evaluate the energy)									
LCI Libraries: Ecoinvent system process									

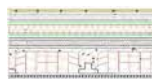
Building element	Flat roof with thermal insulation under the waterproofing with support in lightweight slab of ceramic blocks								Ref: Cob 8
Life-cycle phase	Environmental LCA impact categories							Embodied energy	
	ADP	GWP	ODP	AP	POCP	EP	ENR	ER	
 Cradle-to-gate	8,67E-01	1,76E+02	1,25E-05	7,32E-01	3,63E-02	6,64E-02	1,74E+03	5,56E+01	
End of life	-6,67E-02	-3,23E+00	6,44E-07	-1,29E-02	-5,87E-03	-7,40E-04	-8,01E+01	-3,40E-01	
Total	8,00E-01	1,73E+02	1,31E-05	7,19E-01	3,04E-02	6,57E-02	1,66E+03	5,52E+01	
Comments: Considered Materials: concrete, plaster mortar, geotextile, screed, coating and ceramic pot.									
LCA Method(s): CML 2 baseline 2000 version 2.04 (to evaluate the environmental impact) and Cumulative Energy Demand version 1.04 (to evaluate the energy)									
LCI Libraries: Ecoinvent system process									

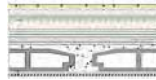
Building element	Flat roof with thermal insulation under the waterproofing with support in lightweight slab of blocks of normal concrete								Ref: Cob 9
Life-cycle phase	Environmental LCA impact categories						Embodied energy		
	ADP	GWP	ODP	AP	POCP	EP	ENR	ER	
 Cradle-to-gate	8,15E-01	1,69E+02	1,18E-05	7,11E-01	3,44E-02	6,45E-02	1,63E+03	4,45E+01	
End of life	-6,70E-02	-3,27E+00	6,36E-07	-1,31E-02	-5,88E-03	-7,85E-04	-8,07E+01	-3,41E-01	
Total	7,48E-01	1,66E+02	1,24E-05	6,98E-01	2,85E-02	6,37E-02	1,55E+03	4,41E+01	
<p>Comments: Considered Materials: concrete, blocks of normal concrete, plaster mortar, geotextile, screed and coating.</p> <p>LCA Method(s): CML 2 baseline 2000 version 2.04 (to evaluate the environmental impact) and Cumulative Energy Demand version 1.04 (to evaluate the energy)</p> <p>LCI Libraries: Ecoinvent system process</p>									

Building element	Flat roof with thermal insulation under the waterproofing with support in lightweight slab of blocks of lightweight concrete								Ref: Cob 10
Life-cycle phase	Environmental LCA impact categories						Embodied energy		
	ADP	GWP	ODP	AP	POCP	EP	ENR	ER	
 Cradle-to-gate	8,98E-01	1,83E+02	1,33E-05	8,29E-01	3,92E-02	7,02E-02	1,82E+03	4,54E+01	
End of life	-6,75E-02	-3,34E+00	6,19E-07	-1,36E-02	-5,90E-03	-8,75E-04	-8,19E+01	-3,42E-01	
Total	8,31E-01	1,80E+02	1,39E-05	8,15E-01	3,33E-02	6,93E-02	1,74E+03	4,50E+01	
<p>Comments: Considered Materials: concrete, blocks of lightweight concrete, plaster mortar, geotextile, screed and coating</p> <p>LCA Method(s): CML 2 baseline 2000 version 2.04 (to evaluate the environmental impact) and Cumulative Energy Demand version 1.04 (to evaluate the energy)</p> <p>LCI Libraries: Ecoinvent system process</p>									

Building element	Landscaped flat roof								Ref: Cob 11
Life-cycle phase	Environmental LCA impact categories						Embodied energy		
	ADP	GWP	ODP	AP	POCP	EP	ENR	ER	
 Cradle-to-gate	7,26E-01	1,26E+02	8,11E-06	5,01E-01	3,51E-02	6,39E-02	1,37E+03	2,07E+01	
End of life	-2,52E-01	-1,72E+01	2,65E-07	-8,34E-02	-1,89E-02	-1,13E-02	-3,58E+02	-1,17E+00	
Total	4,74E-01	1,09E+02	8,38E-06	4,18E-01	1,62E-02	5,26E-02	1,01E+03	1,95E+01	
<p>Comments: Considered Materials: concrete, plaster mortar, geotextile, thermal insulation and cobble.</p> <p>LCA Method(s): CML 2 baseline 2000 version 2.04 (to evaluate the environmental impact) and Cumulative Energy Demand version 1.04 (to evaluate the energy)</p> <p>LCI Libraries: Ecoinvent system process</p>									





Building element	Sloping roof with continuous isolation on plasterboards in component and wooden structure								Ref: Cob 12
Life-cycle phase	Environmental LCA impact categories						Embodied energy		
	ADP	GWP	ODP	AP	POCP	EP	ENR	ER	
 Cradle-to-gate	1,12E-01	-4,59E+00	2,12E-06	5,94E-02	3,80E-03	6,81E-03	2,24E+02	2,90E+00	
End of life	4,28E-03	5,89E-01	1,27E-07	3,50E-03	1,15E-04	7,02E-04	9,37E+00	1,32E-02	
Total	1,16E-01	-4,00E+00	2,25E-06	6,29E-02	3,92E-03	7,51E-03	2,33E+02	2,91E+00	
<p>Comments: Considered Materials: plasterboard, tile, wooden stick, thermal insulation.</p> <p>LCA Method(s): CML 2 baseline 2000 version 2.04 (to evaluate the environmental impact) and Cumulative Energy Demand version 1.04 (to evaluate the energy)</p> <p>LCI Libraries: Ecoinvent system process</p>									

	Building element	Sloping roof with discontinuous thermal insulation in component, with support in solid slab and wooden structure							Ref: Cob 13
	Life-cycle phase	Environmental LCA impact categories						Embodied energy	
		ADP	GWP	ODP	AP	POCP	EP	ENR	ER
	Cradle-to-gate	5,19E-01	7,63E+01	5,05E-06	2,71E-01	2,66E-02	5,04E-02	9,07E+02	1,22E+01
	End of life	-2,67E-01	-1,92E+01	-1,75E-07	-9,56E-02	-1,93E-02	-1,37E-02	-3,90E+02	-1,23E+00
	Total	2,52E-01	5,71E+01	4,88E-06	1,75E-01	7,30E-03	3,67E-02	5,17E+02	1,09E+01
<p>Comments: Considered Materials: concrete, plasterboard, tile, wooden stick, thermal insulation and water proofers.</p> <p>LCA Method(s): CML 2 baseline 2000 version 2.04 (to evaluate the environmental impact) and Cumulative Energy Demand version 1.04 (to evaluate the energy)</p> <p>LCI Libraries: Ecoinvent system process</p>									

	Building element	Sloping roof with discontinuous thermal insulation in component, with support in lightweight slab of ceramic blocks							Ref: Cob 14
	Life-cycle phase	Environmental LCA impact categories						Embodied energy	
		ADP	GWP	ODP	AP	POCP	EP	ENR	ER
	Cradle-to-gate	3,52E-01	5,51E+01	4,55E-06	1,93E-01	1,51E-02	3,01E-02	6,57E+02	2,22E+01
	End of life	-8,25E-02	-5,41E+00	1,75E-07	-2,59E-02	-6,30E-03	-3,34E-03	-1,15E+02	-3,88E-01
	Total	2,70E-01	4,97E+01	4,73E-06	1,67E-01	8,80E-03	2,68E-02	5,42E+02	2,18E+01
<p>Comments: Considered Materials: concrete, vaulted ceramic, plasterboard, tile, wooden stick, thermal insulation and water proofers.</p> <p>LCA Method(s): CML 2 baseline 2000 version 2.04 (to evaluate the environmental impact) and Cumulative Energy Demand version 1.04 (to evaluate the energy)</p> <p>LCI Libraries: Ecoinvent system process</p>									

	Building element	Sloping roof with discontinuous thermal insulation in component, with support in lightweight slab of blocks of normal concrete							Ref: Cob 15
	Life-cycle phase	Environmental LCA impact categories						Embodied energy	
		ADP	GWP	ODP	AP	POCP	EP	ENR	ER
	Cradle-to-gate	3,00E-01	4,89E+01	3,84E-06	1,72E-01	1,31E-02	2,81E-02	5,49E+02	1,11E+01
	End of life	-8,28E-02	-5,45E+00	1,66E-07	-2,61E-02	-6,31E-03	-3,38E-03	-1,15E+02	-3,89E-01
	Total	2,17E-01	4,35E+01	4,01E-06	1,46E-01	6,79E-03	2,47E-02	4,34E+02	1,07E+01
<p>Comments: Considered Materials: concrete, blocks of normal concrete, plasterboard, tile, wooden stick, thermal insulation and water proofers.</p> <p>LCA Method(s): CML 2 baseline 2000 version 2.04 (to evaluate the environmental impact) and Cumulative Energy Demand version 1.04 (to evaluate the energy)</p> <p>LCI Libraries: Ecoinvent system process</p>									

	Building element	Sloping roof with discontinuous thermal insulation in component, with support in lightweight slab of blocks of lightweight concrete							Ref: Cob 16
	Life-cycle phase	Environmental LCA impact categories						Embodied energy	
		ADP	GWP	ODP	AP	POCP	EP	ENR	ER
	Cradle-to-gate	3,84E-01	6,24E+01	5,37E-06	2,91E-01	1,80E-02	3,39E-02	7,34E+02	1,20E+01
	End of life	-8,33E-02	-5,52E+00	1,50E-07	-2,65E-02	-6,32E-03	-3,47E-03	-1,17E+02	-3,91E-01
	Total	3,01E-01	5,69E+01	5,52E-06	2,65E-01	1,17E-02	3,04E-02	6,17E+02	1,16E+01
<p>Comments: Considered Materials: concrete, blocks of lightweight concrete, plasterboard, tile, wooden stick, thermal insulation and water proofers.</p> <p>LCA Method(s): CML 2 baseline 2000 version 2.04 (to evaluate the environmental impact) and Cumulative Energy Demand version 1.04 (to evaluate the energy)</p> <p>LCI Libraries: Ecoinvent system process</p>									

Building element	Sloping roof with sandwich panels in component and wooden structure								Ref: Cob 17
	Life-cycle phase	Environmental LCA impact categories						Embodied energy	
		ADP	GWP	ODP	AP	POCP	EP	ENR	ER
	Cradle-to-gate	1,34E-01	-1,56E+01	1,94E-06	6,87E-02	5,91E-03	8,10E-03	2,68E+02	1,85E+02
	End of life	3,69E-03	5,09E-01	1,09E-07	3,02E-03	9,92E-05	6,05E-04	8,08E+00	1,13E-02
	Total	1,38E-01	-1,51E+01	2,05E-06	7,17E-02	6,01E-03	8,71E-03	2,76E+02	1,85E+02
Comments:	Considered Materials: tile, water proofer, wooden stick, sandwich panel OBS+XPS+OBS.								
	LCA Method(s): CML 2 baseline 2000 version 2.04 (to evaluate the environmental impact) and Cumulative Energy Demand version 1.04 (to evaluate the energy)								
	LCI Libraries: Ecoinvent system process								
Building element	Sloping roof with continuous thermal insulation in the horizontal conveyor, with support in solid slab								Ref: Cob 18
	Life-cycle phase	Environmental LCA impact categories						Embodied energy	
		ADP	GWP	ODP	AP	POCP	EP	ENR	ER
	Cradle-to-gate	5,19E-01	7,63E+01	5,05E-06	2,71E-01	2,66E-02	5,04E-02	9,07E+02	1,22E+01
	End of life	-2,67E-01	-1,92E+01	-1,75E-07	-9,56E-02	-1,93E-02	-1,37E-02	-3,90E+02	-1,23E+00
	Total	2,52E-01	5,71E+01	4,88E-06	1,75E-01	7,30E-03	3,67E-02	5,17E+02	1,09E+01
Comments:	Considered Materials: concrete, water proofer, tile, wooden stick, thermal insulation and plaster mortar.								
	LCA Method(s): CML 2 baseline 2000 version 2.04 (to evaluate the environmental impact) and Cumulative Energy Demand version 1.04 (to evaluate the energy)								
	LCI Libraries: Ecoinvent system process								
Building element	Sloping roof with continuous thermal insulation in the horizontal conveyor, with support in lightweight slab of ceramic blocks								Ref: Cob 19
	Life-cycle phase	Environmental LCA impact categories						Embodied energy	
		ADP	GWP	ODP	AP	POCP	EP	ENR	ER
	Cradle-to-gate	3,04E-01	4,65E+01	3,86E-06	1,73E-01	1,34E-02	2,84E-02	5,57E+02	3,66E+01
	End of life	-8,46E-02	-5,70E+00	1,12E-07	-2,76E-02	-6,36E-03	-3,68E-03	-1,19E+02	-3,95E-01
	Total	2,19E-01	4,08E+01	3,97E-06	1,45E-01	7,04E-03	2,47E-02	4,38E+02	3,62E+01
Comments:	Considered Materials: concrete, vaulted ceramic, water proofer, fiber cement sheet, wooden stick, thermal insulation and plaster mortar.								
	LCA Method(s): CML 2 baseline 2000 version 2.04 (to evaluate the environmental impact) and Cumulative Energy Demand version 1.04 (to evaluate the energy)								
	LCI Libraries: Ecoinvent system process								
Building element	Sloping roof with continuous thermal insulation in the horizontal conveyor, with support in lightweight slab of blocks of normal concrete								Ref: Cob 20
	Life-cycle phase	Environmental LCA impact categories						Embodied energy	
		ADP	GWP	ODP	AP	POCP	EP	ENR	ER
	Cradle-to-gate	2,52E-01	4,02E+01	3,16E-06	1,52E-01	1,14E-02	2,64E-02	4,49E+02	2,55E+01
	End of life	-8,49E-02	-5,74E+00	1,03E-07	-2,78E-02	-6,36E-03	-3,73E-03	-1,20E+02	-3,96E-01
	Total	1,67E-01	3,45E+01	3,26E-06	1,24E-01	5,04E-03	2,27E-02	3,29E+02	2,51E+01
Comments:	Considered Materials: concrete, blocks of normal concrete, water proofer, fiber cement sheet, wooden stick, thermal insulation and plaster.								
	LCA Method(s): CML 2 baseline 2000 version 2.04 (to evaluate the environmental impact) and Cumulative Energy Demand version 1.04 (to evaluate the energy)								
	LCI Libraries: Ecoinvent system process								





Building element	Sloping roof with continuous thermal insulation in the horizontal conveyor, with support in lightweight slab of blocks of lightweight concrete								Ref: Cob 21
	Life-cycle phase	Environmental LCA impact categories						Embodied energy	
		ADP	GWP	ODP	AP	POCP	EP	ENR	ER
	Cradle-to-gate	3,36E-01	5,38E+01	4,69E-06	2,70E-01	1,62E-02	3,22E-02	6,36E+02	2,64E+01
	End of life	-8,55E-02	-5,82E+00	8,72E-08	-2,83E-02	-6,38E-03	-3,82E-03	-1,21E+02	-3,98E-01
Total	2,51E-01	4,80E+01	4,78E-06	2,42E-01	9,82E-03	2,84E-02	5,15E+02	2,60E+01	
<p>Comments: Considered Materials: concrete, blocks of lightweight concrete, water proofer, fibber cement sheet, wooden stick, thermal insulation and plaster mortar.</p> <p>LCA Method(s): CML 2 baseline 2000 version 2.04 (to evaluate the environmental impact) and Cumulative Energy Demand version 1.04 (to evaluate the energy)</p> <p>LCI Libraries: Ecoinvent system process</p>									

Building element	Sloping roof with discontinuous isolation over plaster boards in the horizontal conveyor and wooden structure								Ref: Cob 22
	Life-cycle phase	Environmental LCA impact categories						Embodied energy	
		ADP	GWP	ODP	AP	POCP	EP	ENR	ER
	Cradle-to-gate	7,14E-02	-3,47E+01	2,09E-06	4,68E-02	2,54E-03	5,83E-03	1,36E+02	1,73E+01
	End of life	2,88E-03	3,96E-01	8,52E-08	2,36E-03	7,73E-05	4,71E-04	6,29E+00	8,87E-03
Total	7,43E-02	-3,43E+01	2,18E-06	4,92E-02	2,62E-03	6,30E-03	1,42E+02	1,73E+01	
<p>Comments: Considered Materials: fibber cement sheet, wooden stick, plasterboard, water proofer, thermal insulation and support structure.</p> <p>LCA Method(s): CML 2 baseline 2000 version 2.04 (to evaluate the environmental impact) and Cumulative Energy Demand version 1.04 (to evaluate the energy)</p> <p>LCI Libraries: Ecoinvent system process</p>									

Building element	Sloping roof with sandwich panels in horizontal conveyor								Ref: Cob 23
	Life-cycle phase	Environmental LCA impact categories						Embodied energy	
		ADP	GWP	ODP	AP	POCP	EP	ENR	ER
	Cradle-to-gate	1,40E-01	-3,71E+01	2,59E-06	7,64E-02	6,36E-03	8,75E-03	2,79E+02	1,85E+02
	End of life	4,41E-03	6,08E-01	1,31E-07	3,62E-03	1,19E-04	7,24E-04	9,66E+00	1,36E-02
Total	1,44E-01	-3,65E+01	2,72E-06	8,00E-02	6,48E-03	9,47E-03	2,89E+02	1,85E+02	
<p>Comments: Considered Materials: fibber cement sheet, wooden stick, sandwich panel OBS+XPS+OBS, water proofer, thermal insulation and support structure.</p> <p>LCA Method(s): CML 2 baseline 2000 version 2.04 (to evaluate the environmental impact) and Cumulative Energy Demand version 1.04 (to evaluate the energy)</p> <p>LCI Libraries: Ecoinvent system process</p>									

All.5 Windows

The following pages present the results from the quantification of environmental impact categories of 18 alternative building elements for windows. The functional unit is window with the conventional dimension of 1.50x1.25m². The meaning of the acronyms used in these pages, as well as the unit that express each of the environmental impact categories are shown in Table 6 of this book.



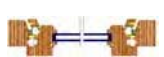

Building element	Glazing with a window frame in aluminium and double glass (outer glass with 4mm, air gap with 22mm and inner glass with 4mm)								Ref: Env 1
	Life-cycle phase	Environmental LCA impact categories						Embodied energy	
		ADP	GWP	ODP	AP	POCP	EP	ENR	ER
	Cradle-to-gate	1,74E+00	2,51E+02	4,63E-05	1,48E+00	1,46E-01	1,24E-01	3,19E+03	1,80E+01
	End of life	-1,12E+00	-1,67E+02	-1,06E-05	-9,11E-01	-7,71E-02	-7,97E-02	-2,01E+03	-7,81E+00
	Total	6,20E-01	8,40E+01	3,57E-05	5,69E-01	6,89E-02	4,43E-02	1,18E+03	1,01E+01
<p>Comments: Materials Considered: glass and aluminium.</p> <p>LCA Method(s): CML 2 baseline 2000 version 2.04 (to assess the environmental impact) and Cumulative Energy Demand version 1.04 (to assess the energy)</p> <p>LCI Libraries: Ecoinvent system process</p>									
Building element	Glazing with a window frame in aluminium and double glass (outer glass with 4mm, air gap with 16mm and inner glass with 10mm)								Ref: Env 2
	Life-cycle phase	Environmental LCA impact categories						Embodied energy	
		ADP	GWP	ODP	AP	POCP	EP	ENR	ER
	Cradle-to-gate	2,17E+00	2,89E+02	1,16E-04	1,82E+00	2,41E-01	1,42E-01	4,04E+03	2,00E+01
	End of life	-1,11E+00	-1,67E+02	-1,06E-05	-9,10E-01	-7,71E-02	-7,95E-02	-2,01E+03	-7,81E+00
	Total	1,06E+00	1,22E+02	1,05E-04	9,10E-01	1,64E-01	6,25E-02	2,03E+03	1,21E+01
<p>Comments: Materials Considered: glass and aluminium.</p> <p>LCA Method(s): CML 2 baseline 2000 version 2.04 (to assess the environmental impact) and Cumulative Energy Demand version 1.04 (to assess the energy)</p> <p>LCI Libraries: Ecoinvent system process</p>									
Building element	Glazing with a window frame in aluminium and double glass (outer glass with 8mm, air gap with 14mm and inner glass with 8mm)								Ref: Env 3
	Life-cycle phase	Environmental LCA impact categories						Embodied energy	
		ADP	GWP	ODP	AP	POCP	EP	ENR	ER
	Cradle-to-gate	1,88E+00	2,75E+02	4,83E-05	1,70E+00	1,53E-01	1,40E-01	3,48E+03	2,30E+01
	End of life	-1,11E+00	-1,67E+02	-1,06E-06	-9,10E-01	-7,70E-02	-7,94E-02	-2,01E+03	-7,81E+00
	Total	7,70E-01	1,08E+02	4,72E-05	7,90E-01	7,60E-02	6,06E-02	1,47E+03	1,51E+01
<p>Comments: Materials Considered: glass and aluminium.</p> <p>LCA Method(s): CML 2 baseline 2000 version 2.04 (to assess the environmental impact) and Cumulative Energy Demand version 1.04 (to assess the energy)</p> <p>LCI Libraries: Ecoinvent system process</p>									
Building element	Glazing with a window frame in PVC and double glass (outer glass with 4mm, air gap with 22mm and inner glass with 4mm)								Ref: Env 4
	Life-cycle phase	Environmental LCA impact categories						Embodied energy	
		ADP	GWP	ODP	AP	POCP	EP	ENR	ER
	Cradle-to-gate	8,67E-01	9,00E+01	1,98E-06	7,19E-01	2,40E-02	6,73E-02	1,77E+03	1,15E+01
	End of life	3,48E-03	4,79E-01	1,03E-07	2,85E-03	9,35E-05	5,71E-04	7,62E+00	1,07E-02
	Total	8,70E-01	9,05E+01	2,08E-06	7,22E-01	2,41E-02	6,79E-02	1,78E+03	1,15E+01
<p>Comments: Materials Considered: glass and PVC.</p> <p>LCA Method(s): CML 2 baseline 2000 version 2.04 (to assess the environmental impact) and Cumulative Energy Demand version 1.04 (to assess the energy)</p> <p>LCI Libraries: Ecoinvent system process</p>									

Building element	Glazing with a window frame in PVC and double glass (outer glass with 4mm, air gap with 16mm and inner glass with 10mm)								Ref: Env 5
	Life-cycle phase	Environmental LCA impact categories						Embodied energy	
		ADP	GWP	ODP	AP	POCP	EP	ENR	ER
	Cradle-to-gate	9,67E-01	1,07E+02	3,39E-06	8,69E-01	2,90E-02	7,88E-02	1,98E+03	1,51E+01
	End of life	4,60E-03	6,34E-01	1,36E-07	3,77E-03	1,24E-04	7,55E-04	1,01E+01	1,42E-02
	Total	9,72E-01	1,08E+02	3,53E-06	8,73E-01	2,91E-02	7,96E-02	1,99E+03	1,51E+01
<p>Comments: Materials Considered: glass and PVC.</p> <p>LCA Method(s): CML 2 baseline 2000 version 2.04 (to assess the environmental impact) and Cumulative Energy Demand version 1.04 (to assess the energy)</p> <p>LCI Libraries: Ecoinvent system process</p>									

Building element	Glazing with a window frame in PVC and double glass (outer glass with 8mm, air gap with 14mm and inner glass with 8mm)								Ref: Env 6
	Life-cycle phase	Environmental LCA impact categories						Embodied energy	
		ADP	GWP	ODP	AP	POCP	EP	ENR	ER
	Cradle-to-gate	1,00E+00	1,13E+02	3,85E-06	9,18E-01	3,07E-02	8,25E-02	2,04E+03	1,09E+01
	End of life	4,97E-03	6,85E-01	1,47E-07	4,07E-03	1,34E-04	8,16E-04	1,35E+01	1,53E-02
	Total	1,00E+00	1,14E+02	4,00E-06	9,22E-01	3,08E-02	8,33E-02	2,05E+03	1,09E+01
<p>Comments: Materials Considered: glass and PVC.</p> <p>LCA Method(s): CML 2 baseline 2000 version 2.04 (to assess the environmental impact) and Cumulative Energy Demand version 1.04 (to assess the energy)</p> <p>LCI Libraries: Ecoinvent system process</p>									

Building element	Glazing with a window frame in wood and double glass (outer glass with 4mm, air gap with 10mm and inner glass with 4mm)								Ref: Env 7
	Life-cycle phase	Environmental LCA impact categories						Embodied energy	
		ADP	GWP	ODP	AP	POCP	EP	ENR	ER
	Cradle-to-gate	3,64E-01	2,19E+00	5,42E-06	3,75E-01	2,29E-02	3,12E-02	6,79E+02	6,02E+00
	End of life	-1,85E-01	-2,77E+01	-1,71E-06	-1,51E-01	-1,29E-02	-1,30E-02	-3,33E+02	-1,31E+00
	Total	1,79E-01	-2,55E+01	3,71E-06	2,24E-01	1,00E-02	1,82E-02	3,46E+02	4,72E+00
<p>Comments: Materials Considered: glass and wood.</p> <p>LCA Method(s): CML 2 baseline 2000 version 2.04 (to assess the environmental impact) and Cumulative Energy Demand version 1.04 (to assess the energy)</p> <p>LCI Libraries: Ecoinvent system process</p>									

Building element	Glazing with a window frame in wood and double glass (outer glass with 4mm, air gap with 6mm and inner glass with 10mm)								Ref: Env 8
	Life-cycle phase	Environmental LCA impact categories						Embodied energy	
		ADP	GWP	ODP	AP	POCP	EP	ENR	ER
	Cradle-to-gate	4,45E-01	1,61E+01	6,56E-06	4,97E-01	2,70E-02	4,05E-02	8,44E+02	8,94E+00
	End of life	-1,84E-01	-2,76E+01	-1,69E-06	-1,50E-01	-1,29E-02	-1,28E-02	-3,31E+02	-1,31E+00
	Total	2,61E-01	-1,15E+01	4,87E-06	3,47E-01	1,41E-02	2,77E-02	5,13E+02	7,63E+00
<p>Comments: Materials Considered: glass and wood.</p> <p>LCA Method(s): CML 2 baseline 2000 version 2.04 (to assess the environmental impact) and Cumulative Energy Demand version 1.04 (to assess the energy)</p> <p>LCI Libraries: Ecoinvent system process</p>									

Building element	Glazing with a window frame in wood and double glass (outer glass with 8mm, air gap with 6mm and inner glass with 8mm)								Ref: Env 9
	Life-cycle phase	Environmental LCA impact categories						Embodied energy	
		ADP	GWP	ODP	AP	POCP	EP	ENR	ER
	Cradle-to-gate	4,72E-01	2,07E+01	6,94E-06	5,37E-01	2,83E-02	4,36E-02	8,98E+02	9,89E+00
	End of life	-1,84E-01	-2,75E+01	-1,68E-06	-1,50E-01	-1,29E-02	-1,28E-02	-3,30E+02	-1,31E+00
	Total	2,88E-01	-6,80E+00	5,26E-06	3,87E-01	1,54E-02	3,08E-02	5,68E+02	8,58E+00
Comments:	Materials Considered: glass and wood.								
	LCA Method(s): CML 2 baseline 2000 version 2.04 (to assess the environmental impact) and Cumulative Energy Demand version 1.04 (to assess the energy)								
	LCI Libraries: Ecoinvent system process								
Building element	Glazing with a window frame with wood in the interior and aluminium in the exterior with double glass(outer glass with 4mm, air gap with 10mm and inner glass with 4mm)								Ref: Env 10
	Life-cycle phase	Environmental LCA impact categories						Embodied energy	
		ADP	GWP	ODP	AP	POCP	EP	ENR	ER
	Cradle-to-gate	5,94E-01	4,75E+01	7,42E-06	5,70E-01	3,83E-02	4,82E-02	1,10E+03	8,48E+00
	End of life	-3,57E-01	-5,34E+01	-3,36E-06	-2,92E-01	-2,48E-02	-2,53E-02	-6,43E+02	-2,51E+00
	Total	2,37E-01	-5,90E+00	4,06E-06	2,78E-01	1,35E-02	2,29E-02	4,57E+02	5,97E+00
Comments:	Materials Considered: glass, wood and aluminium.								
	LCA Method(s): CML 2 baseline 2000 version 2.04 (to assess the environmental impact) and Cumulative Energy Demand version 1.04 (to assess the energy)								
	LCI Libraries: Ecoinvent system process								
Building element	Glazing with a window frame with wood in the interior and aluminium in the exterior with double glass(outer glass with 4mm, air gap with 6mm and inner glass with 10mm)								Ref: Env 11
	Life-cycle phase	Environmental LCA impact categories						Embodied energy	
		ADP	GWP	ODP	AP	POCP	EP	ENR	ER
	Cradle-to-gate	6,86E-01	6,33E+01	8,72E-06	7,08E-01	4,30E-02	5,88E-02	1,28E+03	1,17E+01
	End of life	-3,56E-01	-5,33E+01	-3,34E-06	-2,91E-01	-2,48E-02	-2,52E-02	-6,41E+02	-2,51E+00
	Total	3,30E-01	1,00E+01	5,38E-06	4,17E-01	1,82E-02	3,36E-02	6,39E+02	9,22E+00
Comments:	Materials Considered: glass, wood and aluminium.								
	LCA Method(s): CML 2 baseline 2000 version 2.04 (to assess the environmental impact) and Cumulative Energy Demand version 1.04 (to assess the energy)								
	LCI Libraries: Ecoinvent system process								
Building element	Glazing with a window frame with wood in the interior and aluminium in the exterior with double glass(outer glass with 8mm, air gap with 6mm and inner glass with 8mm)								Ref: Env 12
	Life-cycle phase	Environmental LCA impact categories						Embodied energy	
		ADP	GWP	ODP	AP	POCP	EP	ENR	ER
	Cradle-to-gate	7,16E-01	6,84E+01	9,14E-06	7,53E-01	4,45E-02	6,22E-02	1,35E+03	1,28E+01
	End of life	-3,56E-01	-5,33E+01	-3,33E-06	-2,91E-01	-2,48E-02	-2,51E-02	-6,41E+02	-2,51E+00
	Total	3,60E-01	1,51E+01	5,81E-06	4,62E-01	1,97E-02	3,71E-02	7,09E+02	1,03E+01
Comments:	Materials Considered: glass, wood and aluminium.								
	LCA Method(s): CML 2 baseline 2000 version 2.04 (to assess the environmental impact) and Cumulative Energy Demand version 1.04 (to assess the energy)								
	LCI Libraries: Ecoinvent system process								

Building element	Glazing with a window frame with PVC in the exterior and wood in the interior with double glass(outer glass with 4mm, air gap with 22mm and inner glass with 4mm)								Ref: Env 13
Life-cycle phase	Environmental LCA impact categories							Embodied energy	
	ADP	GWP	ODP	AP	POCP	EP	ENR	ER	
 Cradle-to-gate	1,24E+00	1,10E+02	2,43E-06	9,86E-01	3,30E-02	9,39E-02	2,54E+03	1,49E+01	
End of life	4,94E-03	6,80E-01	1,46E-07	4,04E-03	1,33E-04	8,10E-04	1,08E+01	1,52E-02	
Total	1,24E+00	1,11E+02	2,58E-06	9,90E-01	3,31E-02	9,47E-02	2,55E+03	1,49E+01	
Comments: Materials Considered: glass, PVC and wood.									
LCA Method(s): CML 2 baseline 2000 version 2.04 (to assess the environmental impact) and Cumulative Energy Demand version 1.04 (to assess the energy)									
LCI Libraries: Ecoinvent system process									

Building element	Glazing with a window frame with PVC in the exterior and wood in the interior with double glass(outer glass with 4mm, air gap with 16mm and inner glass with 10mm)								Ref: Env 14
Life-cycle phase	Environmental LCA impact categories							Embodied energy	
	ADP	GWP	ODP	AP	POCP	EP	ENR	ER	
 Cradle-to-gate	1,34E+00	1,28E+02	3,85E-06	1,14E+00	3,80E-02	1,05E-01	2,74E+03	1,85E+01	
End of life	6,06E-03	8,35E-01	1,80E-07	4,96E-03	1,63E-04	9,94E-04	1,33E+01	1,86E-02	
Total	1,35E+00	1,29E+02	4,03E-06	1,14E+00	3,82E-02	1,06E-01	2,75E+03	1,85E+01	
Comments: Materials Considered: glass, PVC and wood.									
LCA Method(s): CML 2 baseline 2000 version 2.04 (to assess the environmental impact) and Cumulative Energy Demand version 1.04 (to assess the energy)									
LCI Libraries: Ecoinvent system process									

Building element	Glazing with a window frame with PVC in the exterior and wood in the interior with double glass(outer glass with 8mm, air gap with 14mm and inner glass with 8mm)								Ref: Env 15
Life-cycle phase	Environmental LCA impact categories							Embodied energy	
	ADP	GWP	ODP	AP	POCP	EP	ENR	ER	
 Cradle-to-gate	1,37E+00	1,33E+02	4,31E-06	1,19E+00	3,97E-02	1,09E-01	2,81E+03	1,96E+01	
End of life	6,43E-03	8,86E-01	1,91E-07	5,27E-03	1,73E-04	1,05E-03	1,41E+01	1,96E-02	
Total	1,38E+00	1,34E+02	4,50E-06	1,20E+00	3,99E-02	1,10E-01	2,82E+03	1,96E+01	
Comments: Materials Considered: glass, PVC and wood.									
LCA Method(s): CML 2 baseline 2000 version 2.04 (to assess the environmental impact) and Cumulative Energy Demand version 1.04 (to assess the energy)									
LCI Libraries: Ecoinvent system process									

Building element	Glazing with a window frame with PVC in the interior and aluminium in the exterior with double glass(outer glass with 4mm, air gap with 22mm and inner glass with 4mm)								Ref: Env 16
Life-cycle phase	Environmental LCA impact categories							Embodied energy	
	ADP	GWP	ODP	AP	POCP	EP	ENR	ER	
 Cradle-to-gate	1,19E+00	1,39E+02	5,19E-06	9,85E-01	4,66E-02	9,07E-02	2,36E+03	1,44E+01	
End of life	-2,58E-01	-3,86E+01	-2,40E-06	-2,11E-01	-1,79E-02	-1,81E-02	-4,64E+02	-1,82E+00	
Total	9,32E-01	1,00E+02	2,79E-06	7,74E-01	2,87E-02	7,26E-02	1,90E+03	1,26E+01	
Comments: Materials Considered: glass, PVC and aluminium.									
LCA Method(s): CML 2 baseline 2000 version 2.04 (to assess the environmental impact) and Cumulative Energy Demand version 1.04 (to assess the energy)									
LCI Libraries: Ecoinvent system process									

Building element	Glazing with a window frame with PVC in the interior and aluminium in the exterior with double glass(outer glass with 4mm, air gap with 16mm and inner glass with 10mm)								Ref: Env 17
Life-cycle phase	Environmental LCA impact categories						Embodied energy		
	ADP	GWP	ODP	AP	POCP	EP	ENR	ER	
 Cradle-to-gate	1,29E+00	1,57E+02	6,60E-06	1,13E+00	5,16E-02	1,02E-01	2,56E+03	1,80E+01	
End of life	-2,57E-01	-3,84E+01	-2,37E-06	-2,10E-01	-1,79E-02	-1,80E-02	-4,61E+02	-1,82E+00	
Total	1,03E+00	1,19E+02	4,23E-06	9,20E-01	3,37E-02	8,40E-02	2,10E+03	1,62E+01	
Comments: Materials Considered: glass, PVC and aluminium.									
LCA Method(s): CML 2 baseline 2000 version 2.04 (to assess the environmental impact) and Cumulative Energy Demand version 1.04 (to assess the energy)									
LCI Libraries: Ecoinvent system process									

Building element	Glazing with a window frame with PVC in the interior and aluminium in the exterior with double glass(outer glass with 8mm, air gap with 14mm and inner glass with 8mm)								Ref: Env 18
Life-cycle phase	Environmental LCA impact categories						Embodied energy		
	ADP	GWP	ODP	AP	POCP	EP	ENR	ER	
 Cradle-to-gate	1,33E+00	1,62E+02	7,07E-06	1,18E+00	5,33E-02	1,06E-01	2,63E+03	1,92E+01	
End of life	-2,56E-01	-3,84E+01	-2,36E-06	-2,09E-01	-1,79E-02	-1,79E-02	-4,61E+02	-1,82E+00	
Total	1,07E+00	1,24E+02	4,71E-06	9,71E-01	3,54E-02	8,81E-02	2,17E+03	1,74E+01	
Comments: Materials Considered: glass, PVC and aluminium.									
LCA Method(s): CML 2 baseline 2000 version 2.04 (to assess the environmental impact) and Cumulative Energy Demand version 1.04 (to assess the energy)									
LCI Libraries: Ecoinvent system process									

All.6. Construction materials

The following pages present the results from the quantification of the environmental impact categories of 47 building materials. The meaning of the acronyms used in these pages, as well as the unit that express each of the environmental impact categories are shown in Table 6 of this book.

Materials	Life-cycle phase	Environmental LCA impact categories						Embodied energy	
		ADP	GWP	ODP	AP	POCP	EP	ENR	ER
Steel in profile	Cradle-to-gate	4.54E-03	5.71E-01	5.40E-08	3.04E-03	1.85E-04	4.86E-04	8.66E00	1.16E-01
Steel for construction (in rod)		1.29E-02	1.25E+00	6.16E-08	5.57E-03	8.29E-04	1.30E-03	3.27E+01	1.52E-01
Wood and cement agglomerate		5.21E-04	-3.27E-02	5.97E-09	3.10E-04	1.40E-05	4.33E-05	1.21E+00	2.08E+00
Aluminium, 50% recycled		2.82E-02	4.28E+00	1.84E-06	3.80E-02	2.23E-03	1.21E-03	6.82E+01	0.00E+00
Lime mortar		1.37E-03	6.10E-01	2.08E-08	8.64E-04	3.91E-05	1.31E-04	3.26E+00	3.27E-01
Cement mortar		4.90E-04	1.95E-01	8.00E-09	3.15E-04	1.29E-05	4.87E-05	1.31E+00	2.10E-01
Tiles/ceramic mosaic		6.30E-03	7.63E-01	8.16E-08	2.93E-03	1.36E-04	2.75E-04	1.40E+01	3.64E-01
Concrete		2.38E-04	1.10E-01	3.55E-09	1.79E-04	6.49E-06	2.84E-05	5.56E-01	6.24E-03
Reinforced concrete		6.08E-04	1.48E-01	3.55E-09	5.56E-04	5.28E-05	5.76E-05	1.24E+00	7.39E-03
Asphaltic bitumen		2.35E-02	5.81E-01	7.27E-07	1.94E-03	1.98E-04	3.02E-04	5.33E+01	9.73E-02
Light concrete block (expanded clay)		2.14E-03	4.29E-01	3.74E-08	2.75E-03	1.14E-04	1.62E-04	4.94E+00	1.60E-01
Light concrete block (porous)		1.40E-03	4.15E-01	2.18E-08	6.69E-04	4.29E-05	8.47E-05	3.25E+00	2.03E-01
Rubber		3.88E-02	3.16E+00	3.09E-09	1.03E-02	6.76E-04	7.64E-04	8.53E+01	5.40E-01
Brita		2.95E-05	4.28E-03	4.08E-10	2.34E-05	1.01E-06	4.15E-06	5.69E-02	1.04E-03
Zinc plate		1.75E+02	2.46E+00	1.37E-07	4.02E-02	1.44E-03	2.41E-03	2.84E+01	5.60E-01
Polyvinyl chloride (PVC)		2.26E-02	1.97E+00	2.84E-09	5.35E-03	3.12E-04	7.59E-04	5.94E+01	9.34E-01
Copper		1.59E-02	1.94E+00	1.53E-07	6.46E-02	2.26E-03	3.97E-03	3.03E+01	5.70E+00
Cork		1.04E-02	-6.54E-01	9.26E-08	5.39E-03	4.55E-04	6.58E-04	2.51E+01	2.72E+01
Foam of glass		1.22E-02	1.58E+00	1.52E-07	3.94E-03	1.76E-04	5.21E-04	3.51E+01	1.29E+00
Iron		1.39E-02	1.50E+00	5.04E-08	5.77E-03	8.73E-04	6.52E-04	2.44E+01	5.70E-01
Fibreglass		7.19E-03	1.03E+00	1.30E-07	2.22E-03	1.56E-04	1.87E-04	1.33E+01	0.00E+00
Rock/mineral wool		1.05E-02	1.46E+00	6.10E-08	8.32E-03	9.28E-04	4.46E-04	2.16E+01	9.79E-01
Glass wool		1.43E-02	1.50E+00	2.15E-07	6.42E-03	5.57E-04	1.18E-03	4.50E+01	4.14E+00
Lumber		1.02E-03	-1.20E+00	1.28E-08	8.05E-04	7.29E-05	1.29E-04	1.98E+00	1.58E+01
Mosaic/ceramic tiles		6.30E-03	7.62E-01	8.16E-08	2.93E-03	1.36E-04	2.75E-04	1.19E+01	3.64E-01
OSB panels		5.33E-03	-9.09E-01	2.15E-08	2.36E-03	3.00E-04	3.51E-04	1.08E+01	2.17E+01
Stone		1.81E-03	2.63E-01	3.43E-08	1.56E-03	4.66E-05	3.13E-04	7.58E+00	8.35E-01
Limestone		1.24E-05	1.92E-03	2.26E-10	3.37E-05	5.38E-07	7.79E-06	2.80E-02	4.05E-04
Expanded perlite		7.08E-03	9.92E-01	2.21E-07	3.04E-03	1.49E-04	3.13E-04	1.63E+01	5.60E-01
Plate of plasterboard		2.48E-03	3.50E-01	3.89E-08	1.09E-03	4.69E-05	1.73E-04	5.74E+00	3.21E-01
Comments:		LCA Method(s): CML 2 baseline 2000 version 2.04 (to evaluate the environmental impact) and Cumulative Energy Demand version 1.04 (to evaluate the energy)							
		LCI Libraries: Ecoinvent system process, ETH-ESU 96 system process, DK INPUT OUTPUT, IDEMAT 2001 and BUWAL; Ecology of Building Materials; DAP of ceramic materials							

Materials	Life-cycle phase	Environmental LCA impact categories						Embodied energy	
		ADP	GWP	ODP	AP	POCP	EP	ENR	ER
Stone plate	Cradle-to-gate	2.99E-03	4.35E-01	5.53E-08	2.56E-03	7.85E-05	5.07E-04	1.36E+01	1.61E+00
Polyester (UP)		1.14E-01	1.97E+01	3.24E-09	1.96E-01	7.42E-03	1.80E-02	2.25E+02	5.52E-01
Expanded polystyrene (EPS)		4.63E-02	4.14E+00	1.10E-07	1.49E-02	6.75E-03	1.24E-03	1.05E+02	1.01E+00
Polyethylene		4.03E-02	1.14E+00	0.00E+00	1.69E-02	4.57E-04	1.63E-03	6.80E+01	0.00E+00
Expanded polystyrene (EPS)		4.63E-02	4.14E+00	1.10E-07	1.49E-02	6.75E-03	1.24E-03	1.05E+02	1.01E+00
Polypropylene		3.24E-02	1.96E+00	1.65E-10	6.19E-03	4.21E-04	6.51E-04	7.46E+01	4.81E-01
Rigid expanded polyurethane		4.31E-02	4.26E+00	1.89E-08	1.77E-02	2.05E-03	2.75E-03	1.00E+02	2.57E+00
PVC		2.26E-02	1.97E+00	2.84E-09	5.35E-3	3.12E-04	7.59E-04	4.69E+01	9.34E-01
Ceramic tile		6.58E-03	8.16E-01	8.41E-08	2.90E-03	1.55E-04	2.85E-04	1.46E+01	7.41E-01
Concrete tile		7.46E-04	2.12E-01	1.11E-08	4.47E-04	2.34E-05	7.64E-05	1.73E+00	1.09E-01
Land and clay		0.00E+00	0.00E+00	0.00E+00	0.00E+00	0.00E+00	0.00E+00	0.00E+00	0.00E+00
Ceramic brick		1.18E-03	2.20E-01	1.58E-08	5.48E-04	4.00E-05	6.71E-05	2.58E+00	2.55E-01
Aqueous base paint		2.37E-02	2.46E00	3.69E-07	1.69E-02	7.72E-04	4.23E-03	4.78E+01	3.33E00
Synthetic base paint		0.0341	2.51	5.78E-7	0.0202	0.000947	0.00547	71.5	4.46E00
Expanded urea-formaldehyde		1.68E-02	8.72E-02	4.31E-09	8.62E-04	1.87E-05	1.53E-04	2.29E+01	2.02E-03
Varnish		1.88E-02	1.75E+00	3.00E-07	9.26E-03	6.13E-04	1.82E-03	3.75E+01	4.39E-01
Glass		5.68E-03	9.73E-01	8.01E-08	8.51E-03	2.86E-04	6.53E04	1.15E+01	2.03E-01
Comments:		<p>LCA Method(s): CML 2 baseline 2000 version 2.04 (to evaluate the environmental impact) and Cumulative Energy Demand version 1.04 (to evaluate the energy)</p> <p>LCI Libraries: Ecoinvent system process, ETH-ESU 96 system process, DK INPUT OUTPUT, IDEMAT 2001 and BUWAL; Ecology of Building Materials; DAP of ceramic materials</p>							

All.7. AVAC and hot water heating equipment

The following pages present the results from the quantification of the environmental impact categories associated with the operation of 12 types of AVAC and hot water heating. The meaning of the acronyms used in these pages, as well as the unit that express each of the environmental impact categories are shown in Table 6 of this book.

Equipment type	Efic. (η_i)	Environmental LCA impact categories						Embodied energy	
		ADP	GWP	ODP	AP	POCP	EP	ENR	ER
Pump air-water heat (heating)	4,00	1,58E-03	2,38E-01	2,61E-07	1,04E-03	4,17E-05	5,53E-05	4,31E+00	2,83E-01
Pump air-water heat (cooling)	3,00	2,11E-03	3,17E-01	3,48E-07	1,39E-03	5,56E-05	7,37E-05	5,75E+00	3,78E-01
Biomass boiler (firewood)	0,68	1,10E-04	2,10E-02	1,57E-09	4,08E-04	6,85E-05	1,45E-04	3,52E-01	5,77E+00
Biomass boiler (pellets)	0,82	3,59E-04	5,56E-02	3,41E-09	4,14E-04	2,54E-05	8,61E-05	5,80E+00	4,91E+00
Natural gas boiler with gas condensation system	0,98	2,12E-03	2,57E-01	3,38E-08	2,17E-04	2,77E-05	1,95E-05	4,38E+00	1,53E-02
Natural gas boiler without gas condensation system	0,87	2,25E-03	2,72E-01	3,58E-08	2,39E-04	2,96E-05	2,29E-05	4,65E+00	1,63E-02
Diesel boiler with gas condensation system	1,00	2,06E-03	3,21E-01	4,76E-08	6,95E-04	3,70E-05	6,28E-05	4,78E+00	3,43E-02
Diesel boiler without gas condensation system	0,94	2,19E-03	3,40E-01	4,96E-08	7,42E-04	3,94E+05	6,65E-05	5,06E+00	3,63E-02
Gas heater	0,50	1,68E-03	3,22E-01	4,25E-08	3,13E-04	3,60E-05	3,43E-05	5,56E+00	1,97E-02
Refrigerating device (absorption cycle/heating)	0,80	6,54E-03	8,65E-01	5,14E-08	7,86E-03	2,95E-04	3,78E-04	1,24E+01	2,20E+00
Refrigerating device (compression cycle/cooling)	3,00	1,74E-03	2,31E-01	1,37E-08	2,10E-03	7,87E-05	1,01E-04	3,30E+00	5,87E-01
Electric resistance heating system	1,00	5,23E-03	6,92E-01	4,11E-08	6,29E-03	2,36E-04	3,02E-04	9,90E+00	1,76E+00
Comentários:		LCA Method(s): CML 2 baseline 2000 version 2.04 (to evaluate the environmental impact) and Cumulative Energy Demand version 1.04 (to evaluate the energy) LCI Libraries: Ecoinvent system process Others: Impacts per kW of heat energy produced. In the quantification of the values presented was taken into account the efficiency of the respective equipment.							



About the book

The proper use of materials, products and construction technologies can significantly contribute to improve the environmental performance of a building life-cycle and therefore its sustainability.

It is widely recognized that Life-Cycle Analysis (LCA) is the best method to assess the environmental impact caused by the construction materials and processes and by the overall life cycle of a construction.

Based on this background, this publication aims to contribute for a more comprehensive application of the LCA method to construction, namely buildings. This book covers, in a streamlined approach, the steps for conducting a life-cycle analysis of a building and contains a database with the environmental life-cycle impacts of building materials, building elements, and HVAC and hot water heating equipments. This database can be used to support design teams decision-making processes towards the selection of materials and building elements with improved environmental performance.

About the book coordinators

Luís Bragança

Professor at the Civil Engineering Department of the University of Minho, director of the Master in Sustainable Construction and Rehabilitation and director of the of Building Physics and Construction Technology Laboratory. He has authored and co-authored more than 200 publications, including books, book chapters, articles in journals and national and international conferences. He is currently President of the International Initiative for Sustainable Built Environment (iiSBE), Chairman of the Board of iiSBE Portugal, coordinator of the European COST Action C25 "Sustainability of Constructions", coordinator of the Committee for Education and Lifelong Learning of iiSBE and coordinator of the Technical Committee TC14 "Sustainability & Eco-Efficiency of Steel Construction". Additionally, he takes part in the CEN/TC350 "Sustainability of Construction Works" and is the representative of the Portuguese Construction Technology Platform (PTPC) in the European Construction Technology Platform (ECTP).

Ricardo Mateus

Ph.D. in Civil Engineering, Assistant Professor at the Civil Engineering Department of the University of Minho and member of the C-TAC research unit. He published two theses in the field of sustainability and is the author and co-author of several national and international books and book chapters and more than 50 scientific papers in the same research domain. He received several awards for scientific and academic work developed, including: Honourable Mention Award "IHRU" (2010) and Honourable Mention Award "André Jordan" (2010). He is a member of several Organizations, Teams and Committees responsible for developing events and initiatives in the field of Sustainable Construction, with emphasis on the Coordination of the Technical Committee of iiSBE Portugal. His fields of research are life-cycle assessment (LCA) of building materials, products and elements and building sustainability assessment (BSA) and rating.