

INFILL MASONRY: SEISMIC BEHAVIOUR OF REINFORCED SOLUTIONS

João LEITE

PhD Student

ISISE, University of Minho

Guimarães, Portugal

joaoleite@civil.uminho.pt

M. PAULO-PEREIRA

PhD Student

ISISE, University of Minho

Guimarães, Portugal

pp@ppsec.pt

Paulo B. LOURENÇO

Full Professor

ISISE, University of Minho

Guimarães, Portugal

pbl@civil.uminho.pt

Abstract

The analysis of buildings constructed in the last 20 years, designed following modern standards, may lead to worrying conclusions. Images of out-of-plane expulsions and in-plane failures of infill walls in recent seismic activities around the world reminded engineers of the consequences of bad practice, wrong solutions or inadequate design.

With the above in mind, a research program is being conducted as a partnership between University of Minho and the National Laboratory for Civil Engineering (LNEC), which includes a shaking table experimental program of framed concrete buildings with masonry infill walls, reinforced and unreinforced.

Herein the shaking table program and the tested solutions are detailed, along with the discussion of the results, focusing on the local behaviour of the infills and the global behaviour of the concrete structure.

Keywords: collapse mode, masonry infill, reinforced concrete frame, reinforcement, shaking table

1. Introduction

Seismic design has two main objectives, namely to: i) prevent local or global collapse of the structure in the event of the design seismic action, retaining structural integrity and residual load bearing capacity after the event - Ultimate Limit State requirement; ii) Withstand a more frequent seismic action without significant damage – Serviceability Limit State requirement. In other words, human lives have to be protected and damage has to be limited in order to keep the rehabilitation of the structure economically feasible. These are the objectives clearly stated in Eurocode 8 (EC8) [1].

Furthermore, this new standard imposes new rules for non-structural members, as in the case of masonry infills. It is stated in article 4.3.6.4 of part 1 of EC8 [1] that the brittle collapse of the infills has to be avoided and that light wire meshes or bed joint reinforcement have to be used. Besides this general information, no more details are given, so there is insufficient information for the structural engineer to correctly design the infills.

It may be stated that infills have been sufficiently studied in the past, and that this is an old

subject, but recent seismic actions might prove this wrong. In Parnitha earthquake, Greece, 60% of the costs in the rehabilitation of the damage caused by the 1999 seismic action were spent on masonry infills. Much damage in infills was also observed in L'Aquila, Italy, in 2009. New generations of seismic codes have been created and applied, but still the behaviour of masonry infill walls has not improved enough.

With the objective of creating simple design rules for these infills, a shaking table test program, performed in LNEC as a partnership with University of Minho, was developed.

2. Testing Models

Three different models were designed to be tested in the shaking table of the LNEC, see Figure 1, and hereafter the details of the first two models (already tested) will be presented.

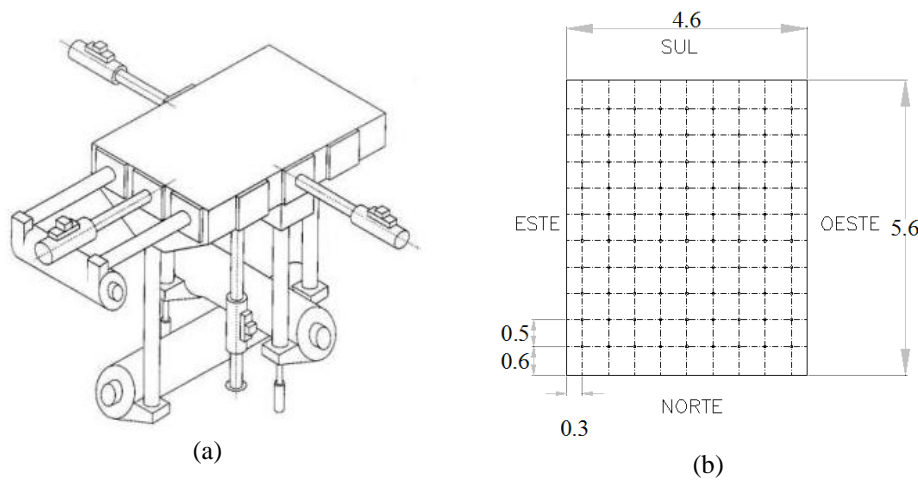

Figure 1: Shaking table of the National Laboratory for Civil Engineering: (a) general view; (b) dimensions of the platform in meters.

2.1 Geometry and Design

The geometry of the tested models was based on a previous study where the average number of storeys, number of bays, and dimensions of the frames and infills was determined. Also, the physical limitations of the shaking table in use had to be taken into account so that the scaled model would fit on the platform, and would not be excessively heavy.

In order to study the different infill solutions, and to correctly represent typical buildings, the structure of the first building was designed following the previous Portuguese codes, R.S.A [2] and R.E.B.A.P.[3], while the other two were designed following EC2 [4] and EC8 [1]. The infill solutions of model one are unreinforced cavity walls and the most common ones, while in the other model single leaf infills are reinforced following the articles of EC8 [1]. For design purposes, the structure is located in the city centre of Lisbon, Portugal. Details of the solution and construction are given below.

The reduction of the dimensions, and all other parameters needed to design the models, was done using Cauchy-Froude's similitude law, see Table 1, for a scale of 1:1,5 which means $\lambda = 1,5$. The dimensions of the models can be seen in Figure 2.

Table 1 – Cauchy-Froude’s similitude law.

Parameter	Scale Factor	Parameter	Scale Factor
Length (L)	$L_p/L_m = \lambda$	Mass (m)	1
Young’s Module (E)	$E_p/E_m = 1$	Weight (w)	λ^2
Specific Mass (ρ)	$\rho_p/\rho_m = \lambda^{-1}$	Force (F)	λ^2
Area (A)	λ^2	Moment (M)	λ^3
Volume (V)	λ^3	Stress (τ)	1
Displacements (d)	λ^2	Strain (ϵ)	1
Velocity (v)	λ	Time (t)	$\lambda^{1/2}$
Acceleration (a)	$\lambda^{1/2}$	Frequency (f)	$\lambda^{-1/2}$

Cauchy is adequate when the restoring forces are derived from the stress-strain relationships and Froude is adequate when the gravity forces are important. For highly non-linear dynamic responses, both laws need to be taken into account [5].

The use of Froude’s law implies additional masses, because of the relation of the specific mass of the prototype and the model. These masses have to be applied to all materials, and in the tested models, only two different solutions for all materials were needed: one for the concrete structure and all the dead and live loads at the floors; another one for the infill masonry walls. These are detailed next.

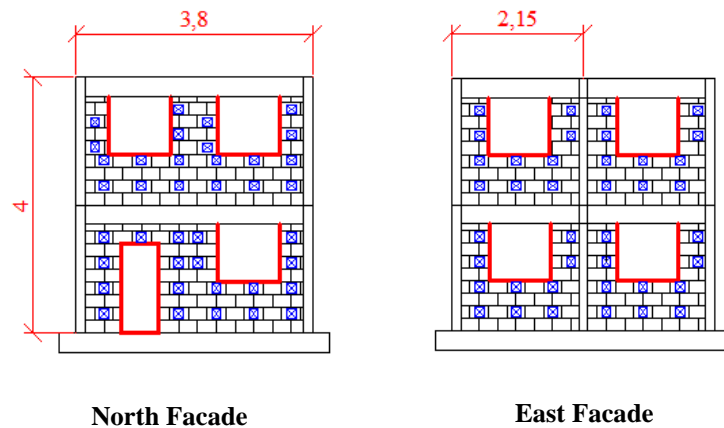

North Facade

East Facade

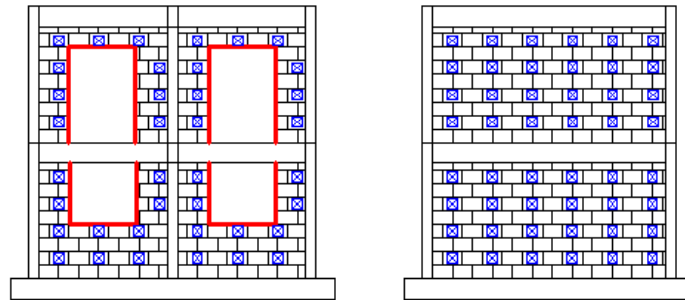

West Facade

South Facade

Figure 2: Facades and dimensions, in meters, of the tested models.

2.2 Construction and Infill Solutions

Due to space limitations in LNEC, the three models were not constructed at the same time, but only the first two were built in a first phase, see Figure 3.



(a)

(b)

Figure 3: Construction of models 1 and 2: (a) concrete structure; (b) infill walls.

It was stated above that two different infill solutions were used for models one and two. Figure 4 shows the details of the solution of model one and its construction. It is a double leaf clay brick cavity wall, unreinforced, and with pre-batched mortar in the bed joints and outer rendering, and it is the most common infill solution used in Portugal in the last two decades.



(a)



(b)

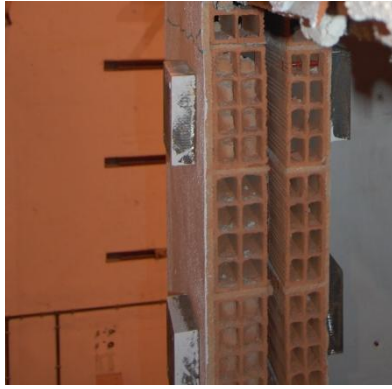

(c)

Figure 4: Infill solution of model one, a double leaf clay brick cavity wall with pre-batched mortar: (a) outer leaf; (b) inner leaf; (c) final work with mortar rendering outside and plaster inside.

The infill solution of model two is single leaf, also with clay bricks and pre-batched mortar, but with bed joint reinforcement connected to the columns of the reinforced concrete frame. The connectors (standard ribbed bars) used were attached to the longitudinal reinforcement steel bars of the columns during construction phase, see Figure 5 (a). The bed joint reinforcement chosen was BEKAERT – MURFOR RND.4/100, see Figure 5 (b), every two courses. The amount of reinforcement was defined following articles 8.2.2, 8.2.3 and 8.2.7 of EC8 [1].

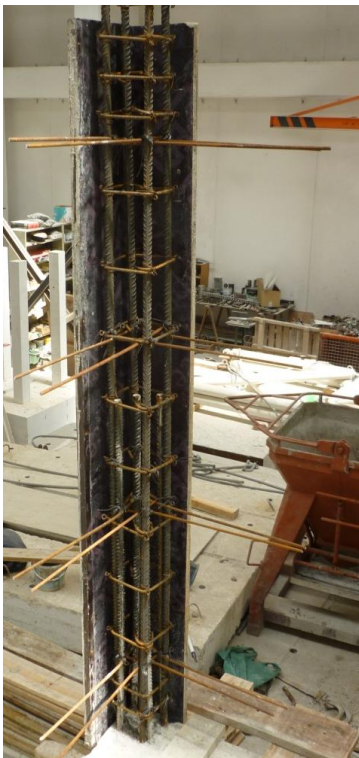

(a)

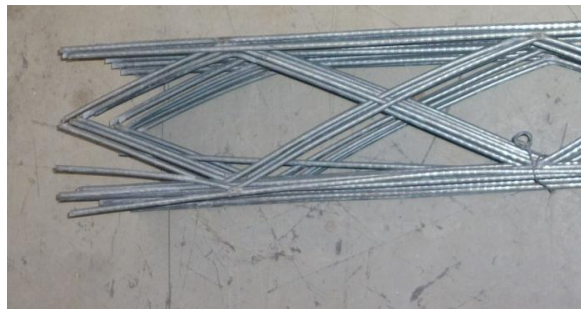

(b)



(c)

Figure 5: Infill solution of model two, a single leaf clay brick wall with pre-batched mortar and bed joint reinforcement: (a) connectors of the bed joint reinforcement to the longitudinal reinforcement steel bars of the columns; (b) Bekaert Murfor RND.4/100; (c) bed joint reinforcement over the connectors in the bed joint layer.

Figure 6 (a) shows the masses used for the concrete structure. Each one has approximately 1200 kg and $82 \times 82 \times 26 \text{ cm}^3$, and six were attached to each floor. Figure 6 (b) shows the

masses used for the infill masonry walls. Each one has approximately 7,2 kg and 15x15x4 cm³. With these dimensions, one steel plate can be attached to a single block and will not connect blocks mechanically. A total number of 334 steel plates were used in each model, half in the inside part of the model and the other half externally. In total, each model weighted about 41 tons.



Figure 6: Additional masses: (a) for the concrete structure and floor loads; (b) for the infill masonry walls.

2.3 Instrumentation

Two different types of behaviour needed to be analysed in the tests: i) the global behaviour of the concrete structure; ii) the local behaviour of the infills. The first was captured using with Hamamatsu cameras at the corners of the building, see Figure 7 (a) and (b), and accelerometers in two corners of each slab, see Figure 7 (c). The local behaviour of the infill walls was measured using accelerometers and in model one, because of the double leaf infill solution constructed, accelerometers had to be placed in the inside and outside, in opposite positions. A total number of 48 accelerometers and 8 Hamamatsu cameras, measuring two in-plane directions, were used.

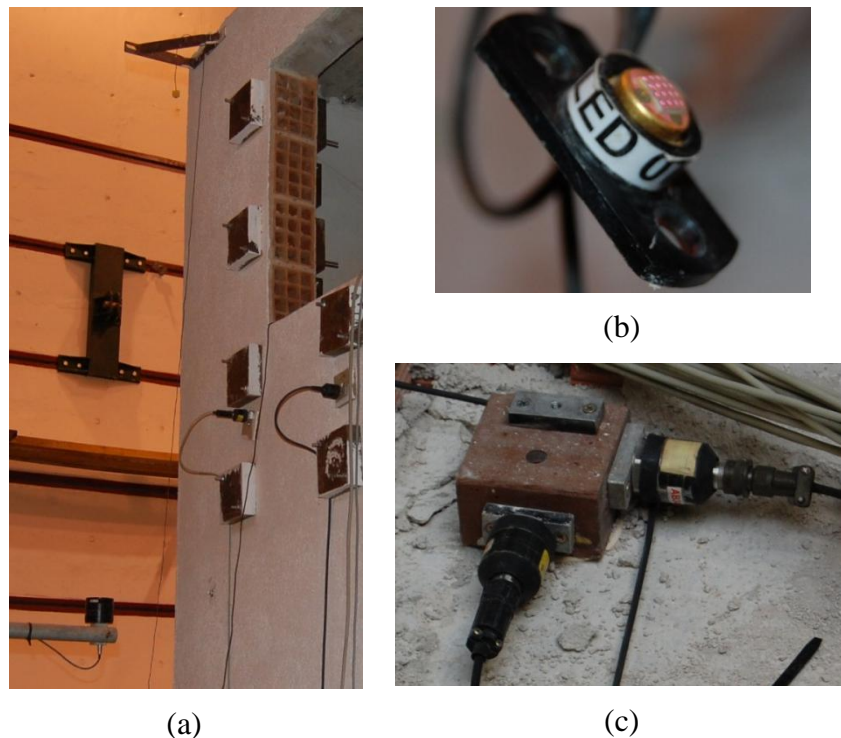

Figure 7: Instrumentation equipments: (a) camera and infra-red led measuring the corner of the second storey slab; (b) detail of the infra-red led; (c) accelerometers in the corner of the

slab measuring transversal directions.

Hamamatsu cameras, model Photonics C5949, are a high resolution position measuring system based on a non-discrete camera and an infra-red led. The camera measures the planar movement of the led. The accelerometer measures unidirectional accelerations within a certain range. The PCB Piezotronics models attached to the structure had a measurement range of $\pm 5g$.

All the measuring instruments were conditioned with cards from PCB Piezotronics (481A02) and National Instruments (series 1300 SCXI modules) inserted into a PXI-1052 from National Instruments, see Figure 8.

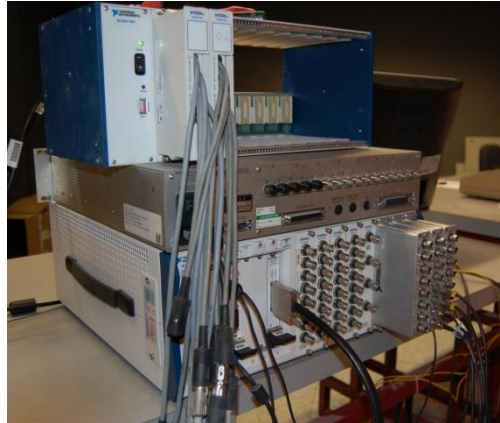

Figure 8: From top to bottom: NI-SCXI-1001 for extra slots, PCB Piezotronics 481A02 and PXI-1052.

2.4 Test Stages

EC8 [1] defines in article 2.1(1) that the design seismic action should have 475 years of return period although, depending on the importance class of the structure, table 4.3 of the code, the maximum surface acceleration should be changed, therefore changing the return period of the seismic action.

Part 3 of EC8 [6] states in article 2.1 that there are three different Limit States, in order to assess and classify the seismic performance of a structure. Each one (NC – near collapse, SD – significant damage, DL – damage limitation) has to be assessed using a seismic action with different years of return period (225, 475 and 2475 years, respectively).

The stages of the shaking table tests, see Table 2, were defined regarding these Limit States. For each stage, an artificial accelerogram, based on the response spectrum, was generated and used as the input signal, see Figure 9 (a). The last stage, number four, was defined as the maximum capacity of the table for the mass of the studied structure. At the beginning, between each stage and at the end, a modal characterization was carried out using a white noise low signal as input. The objective is to determine the dynamic parameters of the structure and their evolution.

Table 2: Stages of the experimental tests for each model

Stage	Years of return period
1	225
2	475
3	2475
4	1,5 x stage 3

The artificial accelerograms were generated in LNEC-SPA – *Signal Processing and Analysis Tools for Civil Engineers*, a software developed in LNEC, and two different accelerograms had to be generated for each stage, one for the longitudinal and other for the transversal directions.

Each stage was tested with masses attached to the table before the actual test, see Figure 9 (b), in order to understand the behaviour of the tri-axial platform and make the necessary calibration. The vertical component was not used.

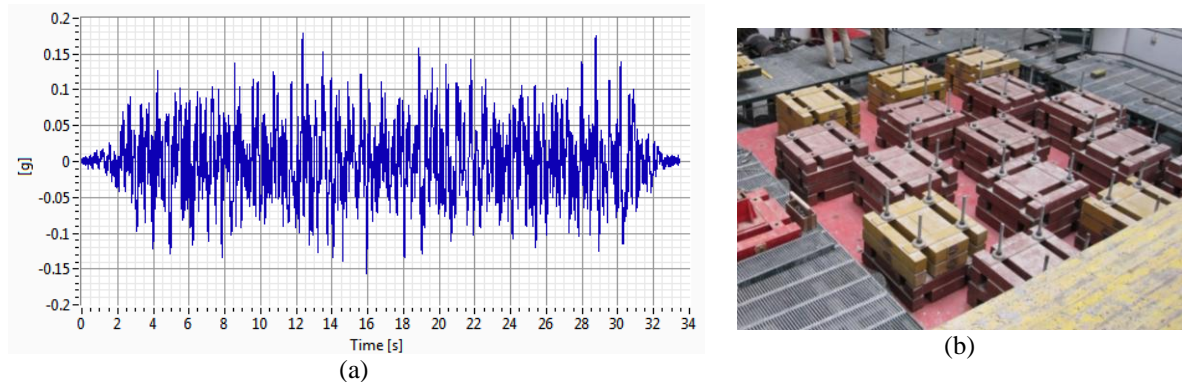

Figure 9: Definition of the experimental test stages: (a) artificial accelerogram generated; (b) calibration of the input signal with masses.

3. Results

Hereafter, results of the shaking table tests of models one and two are presented. Both models were tested in the four stages above defined, and model one collapsed during the last stage. Model two was heavily damaged during this last phase but withstood it. All the infill walls of the first floor of model one, during the last stage and before the failure of three columns, were expelled out-of-plane. None walls of the second model fully collapsed.

3.1 Model 1

The values displayed in Figure 10 (a) were obtained from the accelerometers placed inside the tri-axial platform and are the highest value measured in each stage of the test of model one. These peaks are due to the attempt of the actuators of the shaking table to follow the input in high frequencies. The size and mass of the structure are near the limit values of the table, meaning that the capacity of the table to keep up with the input are compromised for higher frequencies.

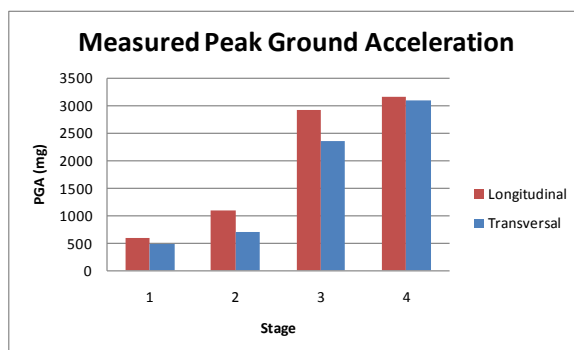

(a)

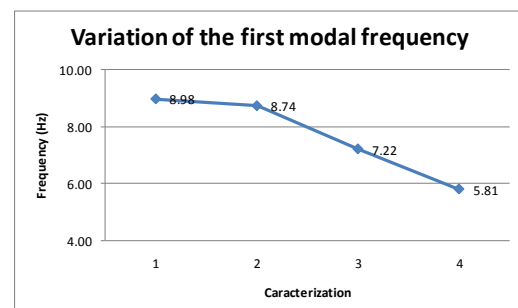

(b)

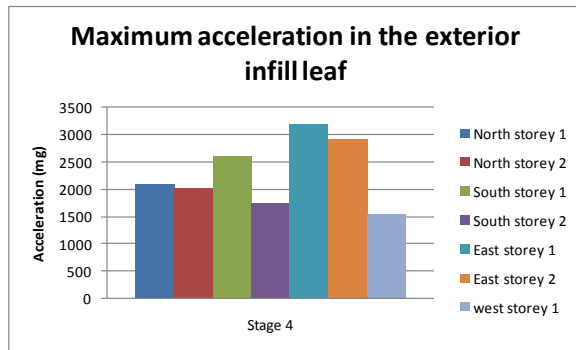

(c)

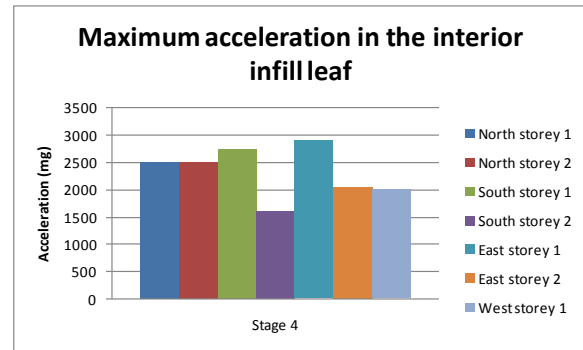

(d)

Figure 10: Results of model one: (a) maximum value of acceleration measured in the tri-axial platform during the four stages of the test; (b) variation of the first modal frequency; (c) maximum acceleration measured by the accelerometers placed in the exterior infill leaf; (d) maximum acceleration measured by the accelerometers placed in the interior infill leaf.

The frequencies in Figure 10 (b) were obtained from peak picking in the frequency response functions. The first characterization was done before stage one, but due to the collapse of the structure, there was no final characterization. The first mode is mainly a transversal (East-West direction) translation, although there is a small torsion component due the non symmetrical distribution of the openings in the infill walls. The first three stages led to a decrease of 35% of the frequency, meaning that the frames in the transversal direction lost a high amount of stiffness. This was a premonition of the collapse recorded for the last stage.

The inner leaf of the infill wall has a thinner block, therefore with higher slenderness, than the outer leaf. Figure 10 (c) and (d) shows that the maximum accelerations of both leaves is similar, even if these cannot be compared directly since the support conditions are different. The outer leaf is 2 to 3 centimetres out of the plane of the frame. All of the walls of the first storey recorded higher peak accelerations than the ones on the second storey.

Although the concrete structure presented some damage after the third stage, found also in the decrease of the first modal frequency, the infills had, until this point, only some cracks at the openings and at the connection to frames, see Figure 11 (a) and (b).

In stage four, the columns of the first floor of the West facade failed due to excessive torsion. Before this happened, all of the infill walls of the first storey had already collapsed out-of-plane, see Figure 11 (c,d). One of the column had all reinforcement stripped off. The infills of the second storey of the model had little damage.

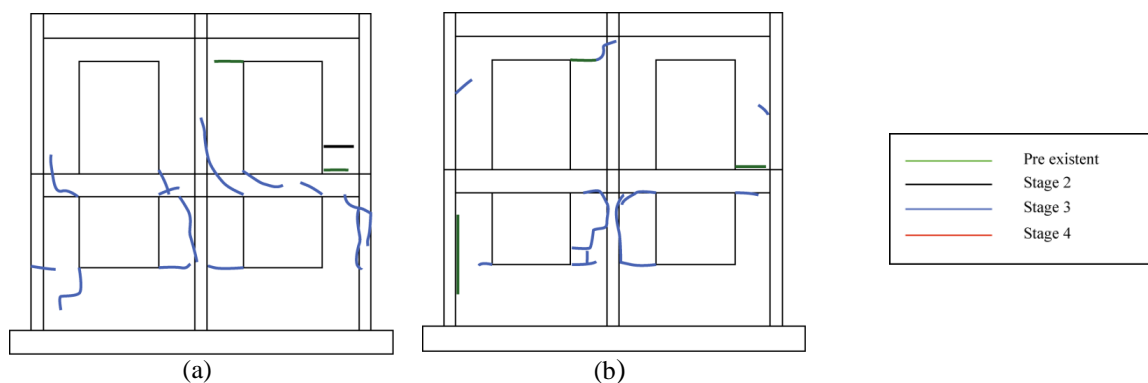

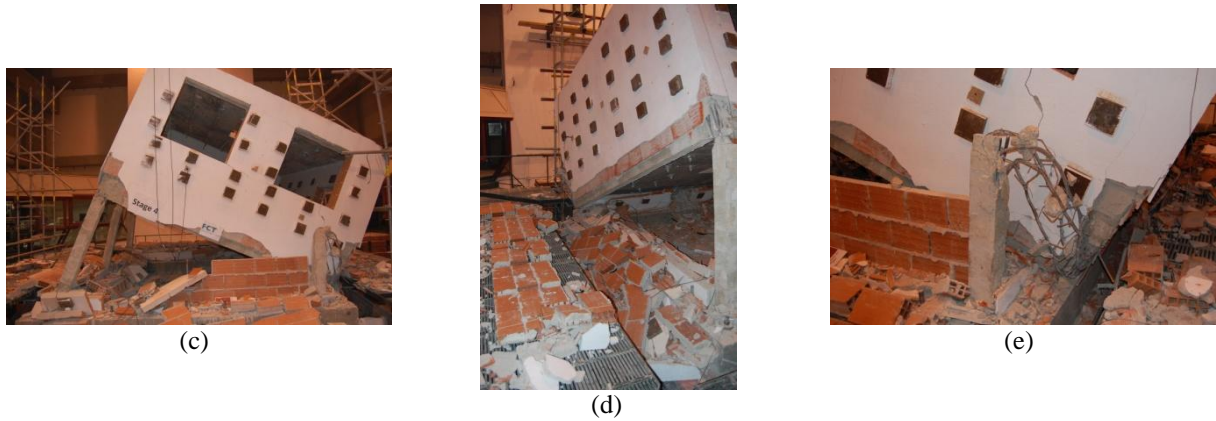

Figure 11: Observed damage in model one: (a) evolution of the cracks in the exterior of facade West; (b) evolution of the cracks in the interior of facade West; (c) North Facade after stage 4; (d) out-of-plane expulsion of the first floor infill wall in the South facade; (e) failure of a corner column of the first floor.

3.2 Model 2

The measured PGA of the test of model two was no different from model one, as the mass and geometry of the structure were the same, see Figure 12.

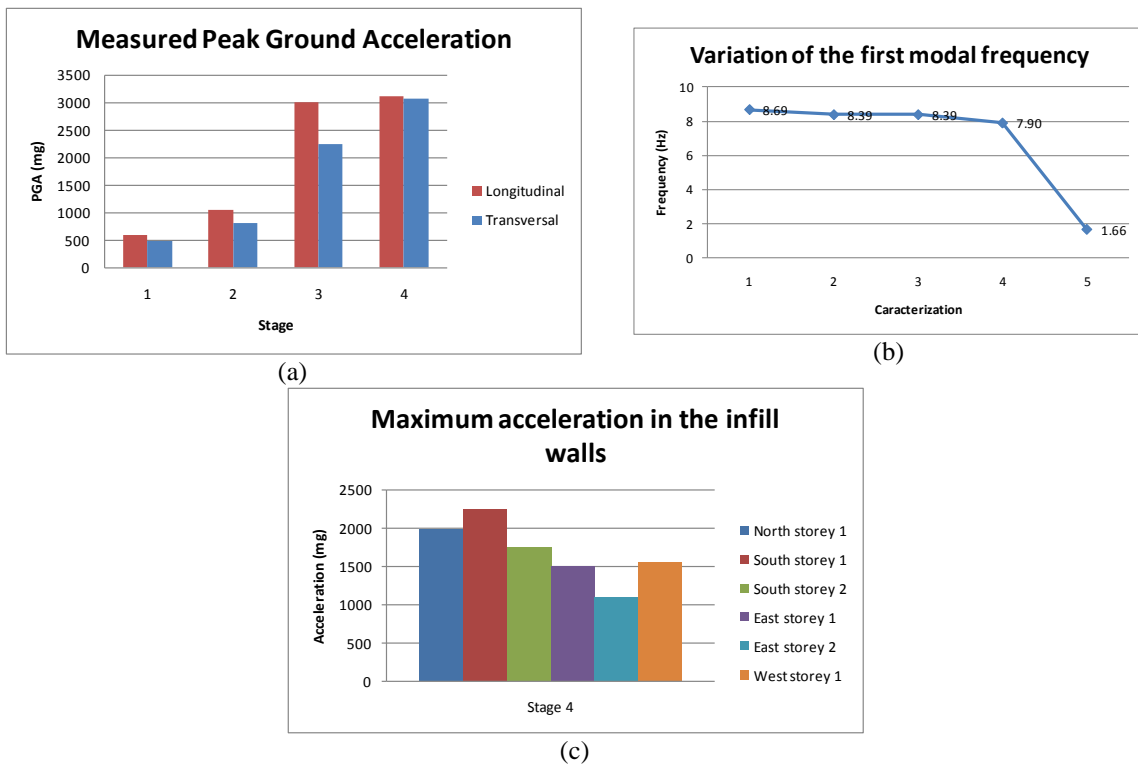

Figure 12: Results of model two: (a) maximum value of acceleration measured in the tri-axial platform during the four stages of the test; (b) variation of the first modal frequency; (c) maximum acceleration measured by the accelerometers placed in the infill wall.

The first modal shape is the same as the previous model, a translation in the transverse direction with a slight torsional component. In this model there are five characterizations, one more than in the previous model, done after stage four. The first three stages led to a decrease of only 10% of the frequency, but the last one clearly damaged the structure beyond repair, with a total decrease of 80% of the modal frequency.

This damage is also clear when analysing Figure 13. In the West facade the cracks followed the same pattern as in the previous model, starting from the corners of the openings and from the connection of the infills with the frames. In stage three, the rendering around the concrete frame felt, mainly at the corners, see Figure 13 (b).

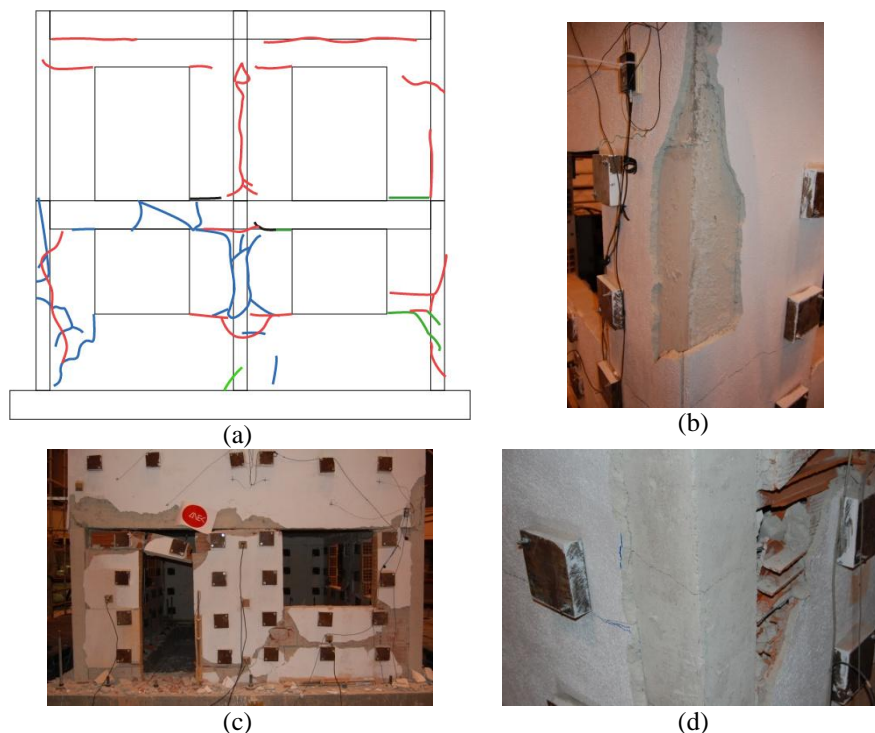

Figure 13: Observed damage in model two: (a) evolution of the cracks in the West facade; (b) expulsion of the mortar rendering in the Northwest corner after stage 3; (c) North Facade after stage 4; (d) shear crack of a corner column of the first floor at mid-height.

During stage four, some infill walls of the first floor became completely disconnected from the concrete frame, see Figure 13 (c), but due to the bed joint reinforcement's connection to the concrete frame, see Figure 5, the out-of-plane collapse was prevented. The infills in the second storey also experienced some damage.

The concrete structure was visibly damaged, with shear cracks at mid height, see Figure 13 (d), and with the detachment of the cover concrete at the beam/column connection in the first floor. It is reasonable to claim that this second model, despite its higher capacity to withstand the fourth stage of the test, was developing an undesirable soft storey failure mode due to the presence of the masonry infills and their collapse at the lower storey.

4. Conclusions

The present work is the first analysis of the results of two shaking table tests on masonry infilled reinforced concrete frames. A more careful study of these results needs to be done, along with numerical simulations, so that solid conclusions can be stated.

The structure designed with the previous Portuguese codes and a double leaf cavity wall, model one, had a poor behaviour when compared with model two, designed according to Eurocodes with a single leaf larger wall. The first structure fully collapsed in the fourth and last stage of the test. The second structure was heavily damaged, beyond repair, but withstood all the stages, even though the developed failure mode was undesirable.

All of the walls of the first storey of model one were expelled out-of-plane before the structure collapsed, while none of the walls of model two collapsed (even if significantly

damaged). The better behaviour of the infills in model two was due to the presence of bed joint reinforcement connected to the infill frame.

5. References

- [1] Eurocode-8, *Design of structures for earthquake resistance - Part 1: General rules, seismic actions and rules for buildings* (EN 1998-1), European Committee of Standardization 2004: Brussels, Belgium.
- [2] R.S.A., *Regulamento de Segurança e Accões para Estruturas de Edifícios e Pontes*. 1983: Diário da República.
- [3] R.E.B.A.P., *Regulamento para Estruturas de Betão Armado e Pré-Esforçado*. 1983: Diário da República.
- [4] Eurocode-2, *Eurocode 2: Design of concrete structures - Part 1: General rules and rules for buildings*, (EN-1992-1-1) European Committee of Standardization. 2002: Brussels, Belgium.
- [5] Carvalho, E.C., *Seismic testing of structures*, in *11th European Conference on Earthquake Engineering*. 1998: Balkema, Rotterdam.
- [6] Eurocode-8, *Eurocode 8: Design of structures for earthquake resistance - Part 3: Assessment and retrofitting of buildings* (EN 1998-3), European Committee of Standardization 2005: Brussels, Belgium.